

Final report – Johan Cruijff ArenA Operational Pilot

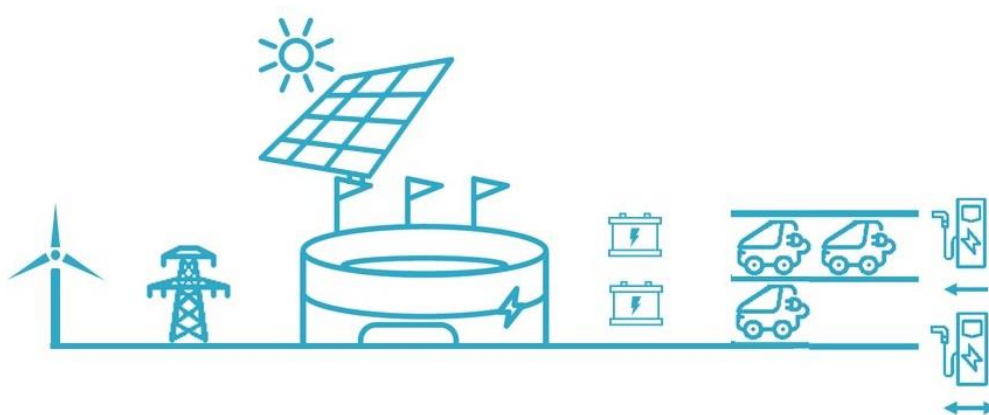

Subtitle: Johan Cruijff ArenA Case Study

Author: Jos Warmerdam (AUAS), Jorden van der Hoogt (Cenex NL), Richard Kotter (UNN)

Date: Oct 08, 2020

Participants:

- University of Applied Science: Jos Warmerdam, Aymeric Buatois, Daniel Roose (student AUAS), Bastiaan Engelenburg (student AUAS)
- Johan Cruijff ArenA: Tim Oosterop
- The Mobility House: Jan Winkler
- University of Northumbria: Richard Kotter; Edward Bentley
- Cenex Nederland: Jorden van der Hoogt; Esther van Bergen

Document control

Version	Date	Authors	Approved	Comment
V1.0	15/07/2020	JW, JvdH, RC	JW	Internal release SEEV4-City
V1.1	11/08/2020	JW, JvdH,	JW, EvB	Updated with feedback from partners and finalized layout
V1.2	08/10/2020	JW	JW	Final version for public release





Table of Contents

- EXECUTIVE SUMMARY..... 3**
- GLOSSARY..... 5**
- 1. ABOUT THE PILOT 6**
 - 1.1. Local context and Energy Profile 6**
 - 1.2. Electric energy system..... 7**
 - 1.3. SEEV4-City objectives and KPI targets..... 11**
 - 1.4. Local partners 11**
- 2. DATA COLLECTION AND PROCESSING..... 13**
 - 2.1. Total electricity demand and PV production 13**
 - 2.2. Static battery, EV chargers and V2G unit 15**
- 3. SEEV4-CITY RESULTS – KEY PERFORMANCE INDICATORS (KPIS)..... 18**
 - 3.1. Methodology (summary) 18**
 - 3.2. Baseline and Final measurements 18**
 - 3.3. KPI result conclusions 20**
- 4. COST-BENEFIT ANALYSIS 21**
 - 4.1. The stationary battery energy storage system (BESS) 21**
 - 4.2. The V2G facility..... 22**
 - 4.3. Overall business model 28**
- 5. LESSONS FROM THE DIFFERENT PILOT PHASES 30**
 - 5.1. Preparation and initiation..... 30**
 - 5.2. Procurement 30**
 - 5.3. Implementation and installation..... 30**
 - 5.4. Operation 31**
- 6. CONCLUSIONS AND RECOMMENDATIONS..... 32**
 - 6.1. Project and system recommendations 32**
 - 6.2. Relevant dimensions for Upscaling and Transnational transfer potential 32**
 - 6.3. Policy suggestions 35**
- REFERENCES 36**





Executive Summary

This report provides a final report of the SEEV4-City Operational Pilot (OP) at Johan Cruijff ArenA, in Amsterdam, The Netherlands. It is part of a collection of reports published by the project covering a variation of specific and cross-cutting analysis and evaluation perspectives and spans 6 operational pilots. This report is dedicated to the analysis of the pilot itself. Below an indication of the set of reports is provided, including an indication where this OP report fits in.

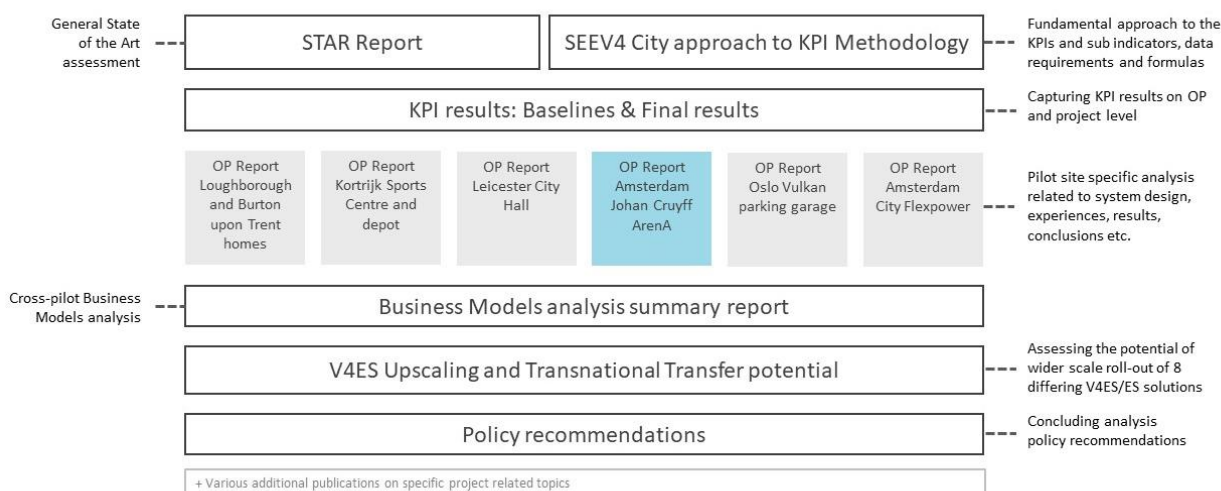

The Johan Cruijff ArenA (JC ArenA) is a big events location in Amsterdam, where national and international football matches, concerts and music festivals take place for up to 68,000 visitors. The JC ArenA is already one of the most sustainable, multi-functional stadia in the world and is realizing even more inspiring smart energy solutions for the venue, it’s visitors and neighbourhood. The JC ArenA presents a complex testbed for innovative energy services, with a consumption of electricity comparable to a district of 2700 households. Thanks to the 1 MWp solar installation on the roof of the venue, the JC ArenA already produces around 8% of the electricity it needs, the rest is by certified regional wind energy.

Within the Seev4-City project the JC ArenA has invested in a 3 MW/2.8 MWh battery energy storage system, 14 EV charging stations and one V2G charging unit. The plan was to construct the 2.8 MWh battery with 148 2nd life electric car batteries, but at the moment of realisation there were not enough 2nd life EV batteries available, so 40% is 2nd life. The JC ArenA experienced compatibility issues installing a mix of new and second-life batteries. Balancing the second-life batteries with the new batteries proved far more difficult than expected because an older battery is acting different compared to new batteries.

The EV-based battery energy storage system is unique in that it combines for the first time several applications and services in parallel. Main use is for grid services like Frequency Containment Reserve, along with peak shaving, back-up services, V2G support and optimization of PV integration. By integrating the solar panels, the energy storage system and the (bi-directional) EV chargers electric vehicles can power events and be charged with clean energy through the JC ArenA’s Energy Services. These and other experiences and results can serve as a development model for other stadiums worldwide and for use of 2nd life EV batteries.

The results of the Seev4-City project are also given in three Key Performance Indicators (KPI): reduction of CO₂-emission, increase of energy autonomy and reduction in peak demand. The results for the JC ArenA are summarised in the table below. The year 2017 is taken as reference, as most data is available for this year. The CO₂ reductions are far above target thanks to the use of the battery energy storage system for FCR services, as this saves on the use of fossil energy by fossil power plants. Some smaller savings are by replacement of ICE



by EV. Energy autonomy is increased by better spreading of the PV generated, over 6 instead of 4 of the 10 transformers of the JC Arena, so less PV is going to the public grid. A peak reduction of 0.3 MW (10%) is possible by optimal use of the battery energy storage system during the main events with the highest electricity demand.

JC Arena Operational Pilot – KPIs			
KPI		Target	Results
A	CO ₂ Reduction	15-40 ton CO ₂ yearly	2012 ton CO ₂ yearly
	Sub-KPI: ZE km increase factor	ZE km increase factor: 3	From 0 to 178204 km
B	Energy Autonomy increase	Remains same	Increase by 1.2%
C	Grid Investment deferral (by peak demand reduction)	Target is at national scope	10% peak reduction (0.3 MW) at JC Arena

Most earnings for the BESS are by the FCR services. Investments are not known exactly, as part of the costs are taken by some of the project partners as they want to learn from this project. The cost for the stationary battery energy storage was roughly 650 k€ per MWh. This is close to what the Operational Pilot paid but because of the additional use cases such as Back-up power, integration of V2G and FCR services, the real cost in this Operational Pilot was about 50% higher, especially in terms of hours put in by each of the partners. Break even should be after 10 years for the business case.

First test are done with V2G services. With 2,000 parking spaces at the JC Arena, there is a huge potential for optimisation here in energy balancing. Business models have to be tested, for example with reduced parking fees or free catering or publicity for participants or another non-monetary compensation. Dynamic load management of the 14 EV chargers saved on installation costs, and this can be extended to the new future EV/V2G charging units.

A key aspect of the JC Arena pilot is that it has adopted multiple (vehicle4) energy services, in effect it is a real living lab environment where several technological solutions exist together. This makes it particularly interesting as it shows that locations do not have to necessarily chose between one or the other. As such, (parts of) these techniques and services can be used at a larger scale and in other countries as well.

Glossary

Term	Abbreviation	Definition
Battery (Energy) Storage System	BSS or BESS	The combination of software and hardware which comprises a battery, bidirectional inverter that can respond to external signals, e.g. from an EMS.
Battery Electric Vehicle	BEV	This refers to battery electric vehicles only.
Charge Point Operator	CPO	A company operating a pool of charging points.
Distribution System Operator	DSO	Network operator on medium and low voltage level.
Energy Management System	EMS	The software and associated hardware required to manage the energy of a site or building, typically with the aim of reducing energy costs or reduce CO ₂ emissions.
Electric vehicle	EV	Plug-in Hybrid or Battery Electric Vehicle.
Frequency Containment Reserve	FCR	Operating reserves necessary for constant containment of frequency deviations (fluctuations) from nominal. FFR in the UK.
Johan Crujff Arena	JC Arena	The sports and events location. Home to Ajax, the Dutch national team, concerts and business events.
Key Performance Indicator	KPI	A metric which has been identified to best measure and communicate the performance along a certain dimension.
Operational Pilot	OP	One of the pilot projects funded by the SEEV4-City project.
Photovoltaic	PV	Conversion of sunlight to direct current electricity via the photovoltaic effect. An inverter converts this electricity to alternating current for use on the grid.
State of Charge	SOC	Amount of energy in the battery, percentage between 0-100%
The Mobility House	TMH	Software company that integrates the energy systems of the JC Arena.
Transmission System Operator	TSO	Operator of the (national) High Voltage Grid. In The Netherlands this is Tennet.
Vehicle to grid	V2G, V2X	Electricity of the EV going into the (public) grid (to other)
(Electric)Vehicle4EnergyServices	(E)V4ES	Use of electric vehicles for energy services.

1. About the pilot

1.1. Local context and Energy Profile

The Johan Crujff Arena is located in the southern part of Amsterdam and is the home base of football club Ajax. The Dutch national team also plays international matches in the stadium. Concerts and dance parties regularly supplement the calendar of events. The seat capacity is 55,000 and during concerts up to 68,000 visitors are possible. The total building size is approximately 60,000 m². In Figure 1 the JC Arena is seen from above, with the PV system visible at the roof.

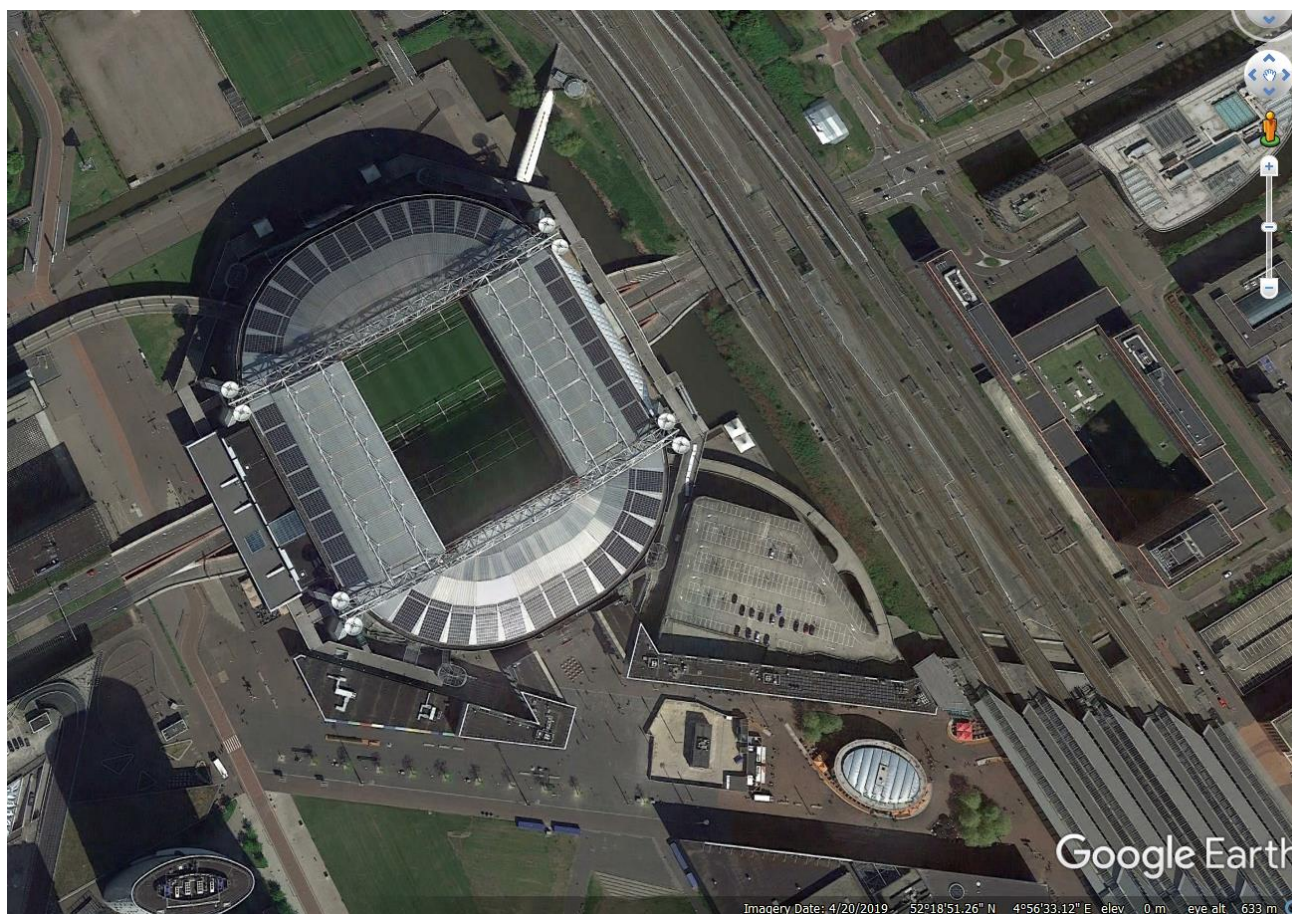

Figure 1: Google earth picture of the Johan Crujff Arena.

The 1 MWp PV system provides about 8% of the yearly electric energy demand (857 MWh PV production, and total electricity demand was 8610 MWh in 2017), and the rest of the electricity demand is made green by buying wind energy from a wind park in the north of the province. For the heat demand the JC Arena is connected to the district heating system of the Diemen power plant, and cold is coming from a nearby lake. During events, the total electric power demand peaks at 3 MW. Diesel generators of 0,7 MW total are on site for back-up power of the most essential functions during power outages. With the new 3 MW/2.8 MWh battery energy storage system more back-up power is available and life coverage of football matches can continue.

The JC Arena pilot is not about providing a testbed in a living lab environment where multiple solutions are implemented to showcase and learn from innovative solutions. The system is composed of a combination of several hardware components used as building blocks for the adoption of more than one (Vehicle4)Energy Service (V4ES) that co-exist and are used complementary to each other on one specific site. The schematic below provides a visual of the various building blocks and adopted solutions. In the section 'Electric energy system' that follows the different components are elaborated on in more (technical) details.



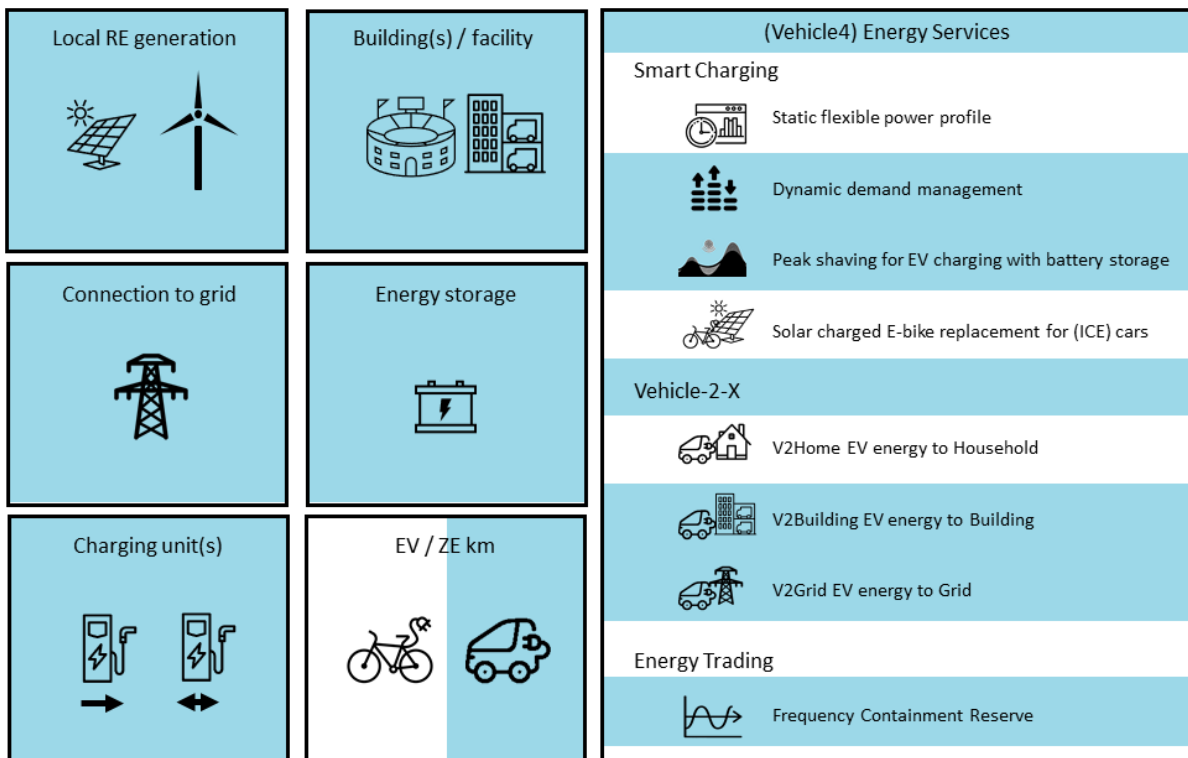

Figure 2 - Pilot schematic – system design components

The JC Arena wants to minimize the footprint of the stadium and its visitors, by use of a mix of proven sustainability measures and innovative technology. The stadium is the perfect testing ground for developing and testing innovations. Besides the Seev4-City investments, the stadium energy-generating escalators, LED lighting during events, electric lawn mowers are used, as well as sensors that facilitate efficient data-driven management and maintenance. Visitors are encouraged to use public transport or bring their electric car.

This fits in the Clean Air Action Plan of the City of Amsterdam [1]. Amsterdam is already a frontrunner in the field of electric vehicles, and in the coming years efforts to promote them will be intensified. Increasingly there will come zero-emission zones, and from 2030, the entire built-up area of Amsterdam will be emission-free for all forms of transport, including cars and motorbikes.

1.2. Electric energy system

Grid connection

The electricity system of the JC Arena is connected with the public grid by 10 transformers of 10 kV/400V. Four of them are located on the westside of the stadium and are named A1-A2-A3-A4, and four on the eastside named B1-B2-B3-B4. Two more are dedicated to the second ring in the JC Arena and are also located on the westside, named C1-C2. The capacity of the B1 and B3 transformer is 630 kVA, the others are 1000 kVA each. So total capacity with the grid is 9.26 MVA. Figure 3 shows the electrical wiring system, with the ten transformers on the lower side.



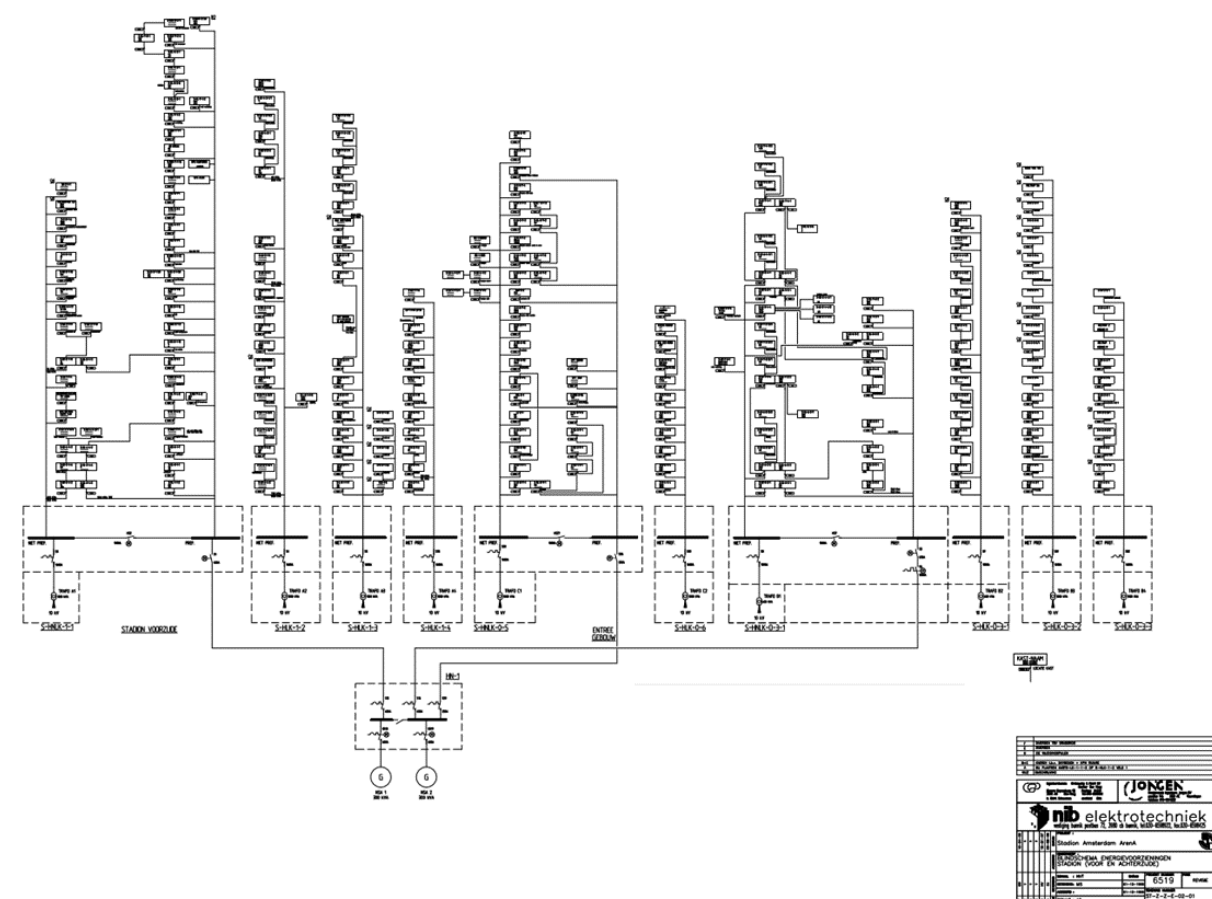

Figure 3: Electrical wiring scheme of the JC Arena.

PV system

The JC Arena already has a PV system on its roof, consisting of about 4,000 solar panels of 270 Wp each, making the total installed capacity approximately 1 MWp. As can be seen on Figure 1 these PV panels are located all around the roof. The PV system has 8 electricity meters, connected to the transformers A2, A3, B4 and C2.

Diesel generator backup system

As back-up for the most essential electrical functions, the JC Arena has three diesel generators Perkins P300X, model G 240 S (Figure 4). Their power is 240 kW each, so total backup power is 720 kW = 0,7 MW. Two are located on the westside, one at the eastside. This backup power is enough to keep the essential functions working during power outages-of the public grid.

At standby the diesel fuel use is 63.1 ltr/hour. With an energy content of 38.6 MJ/ltr, this gives an efficiency of 35% for these generators. These diesel generators are tested every month by running them for one hour.

Technically the new battery energy storage system could replace the diesel generators, but this will require new permitting. And as the permitting procedures are not suited well for new BESS systems, the diesel back-up generators will stay in function for the coming years.





Figure 4: Diesel back-up generator in the JC Arena (photo by J.Warmerdam)

3 MW battery energy storage system (BESS)

The static battery has a capacity of 2.8 MWh and a power of 3 MW, and is made from 148 Nissan Leaf car batteries, of which 40% 2nd life. The four services that are possible with the static battery are:

- Optimized PV integration
- Backup power
- Grid services - FCR
- Peak shaving

Some of these services are conflicting so choices have to be made which service is optimal for which situation. For example, when using the battery for FCR, it cannot be used for the other services, for a whole day. The 3 MW battery is connected to the transformers A1, A2, A3 and A4.



Figure 5: Part of the 3 MW battery system (photo by B. Jablonska).

EV chargers

In 2019 14 AC chargers of 22 kW each are installed. When all chargers are used at their maximum output, the demand equals 308 kW. This peak will not occur often, however, a smart management system is developed and installed so the peak limit can be set flexible. The local energy infrastructure is designed for a max of 210 A (145 kW). This saved 15 k€ on installation and cabling costs.

V2X unit

A trial has started with one V2G unit of 10 kW (Figure 6). Just one as prices are still high for V2G units. With V2G units, the car batteries can also be used for the services already provided by the static battery. In the future more of these units will be installed. Figure 7 shows how the V2G unit interacts with the rest of the energy system.



Figure 6: Two of the EV chargers (on the left) and the V2G unit (on the right).

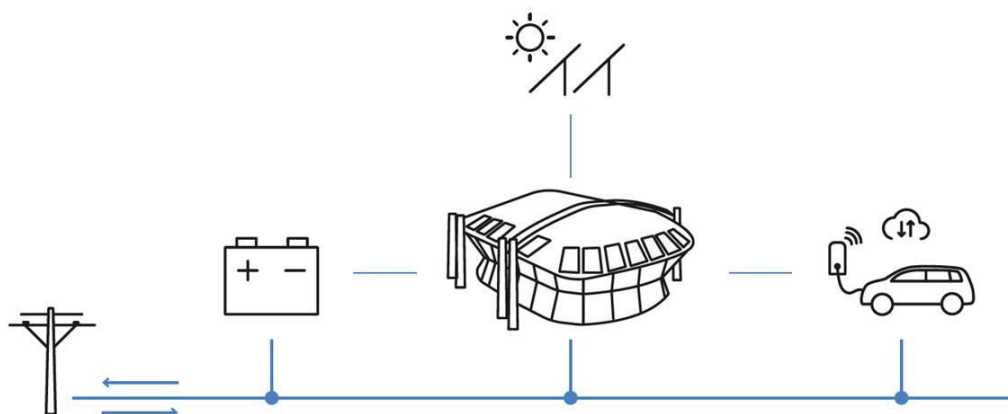

Figure 7: Scheme of the interaction of the V2G unit with the rest of the Arena system.

1.3. SEEV4-City objectives and KPI targets

In the period of the Seev4-City project several measures were taken. An important one is the installation of a 2.8 MWh, 3 MW static battery energy storage system. Another one is the use of 14 AC charging stations of 22 kW each, and 1 V2G unit of 10 kW. To increase the energy autonomy the PV system is connected to two more transformers.

Regarding the Seev4-City KPIs, the JC Arena pilot has three main objectives:

- Use of static battery for four services (effect on KPIs: CO₂-reduction, Energy autonomy, peak reduction)
- Use of V2X with bi-directional chargers (effect on KPI's: CO₂-reduction, peak reduction)
- Power balancing and maximization with uni-directional EV chargers (effect on KPI: peak reduction)

Pilot's SEEV4-City KPI targets:

JC Arena OP – KPIs		
KPI		target
A	CO ₂ Reduction	15-40 ton CO ₂ yearly
	(sub-KPI) ZE km increase factor:	3
B	Energy Autonomy increase	Remain same
C	Grid Investment deferral (by peak demand reduction)	Target is at national scope

1.4. Local partners

The Johan Crujff Arena is very ambitious in becoming the most innovative and sustainable stadium in the world. For realising the energy part, a new company was created: the Amsterdam Energy Arena. The purpose of this company, and its main partners, are shown in Figure 8.

Partners and their role:

Amsterdam Johan Crujff Arena	Sports and events location
Battery Storage Provider	EATON and Nissan
V2G & Battery Storage Management	The Mobility House
Contractor Maintenance of Installations	BAM Techniek
Distribution Network Operator	Liander
TSO	TenneT
Parking/ Garage Owner	Parkeergebouwen Amsterdam

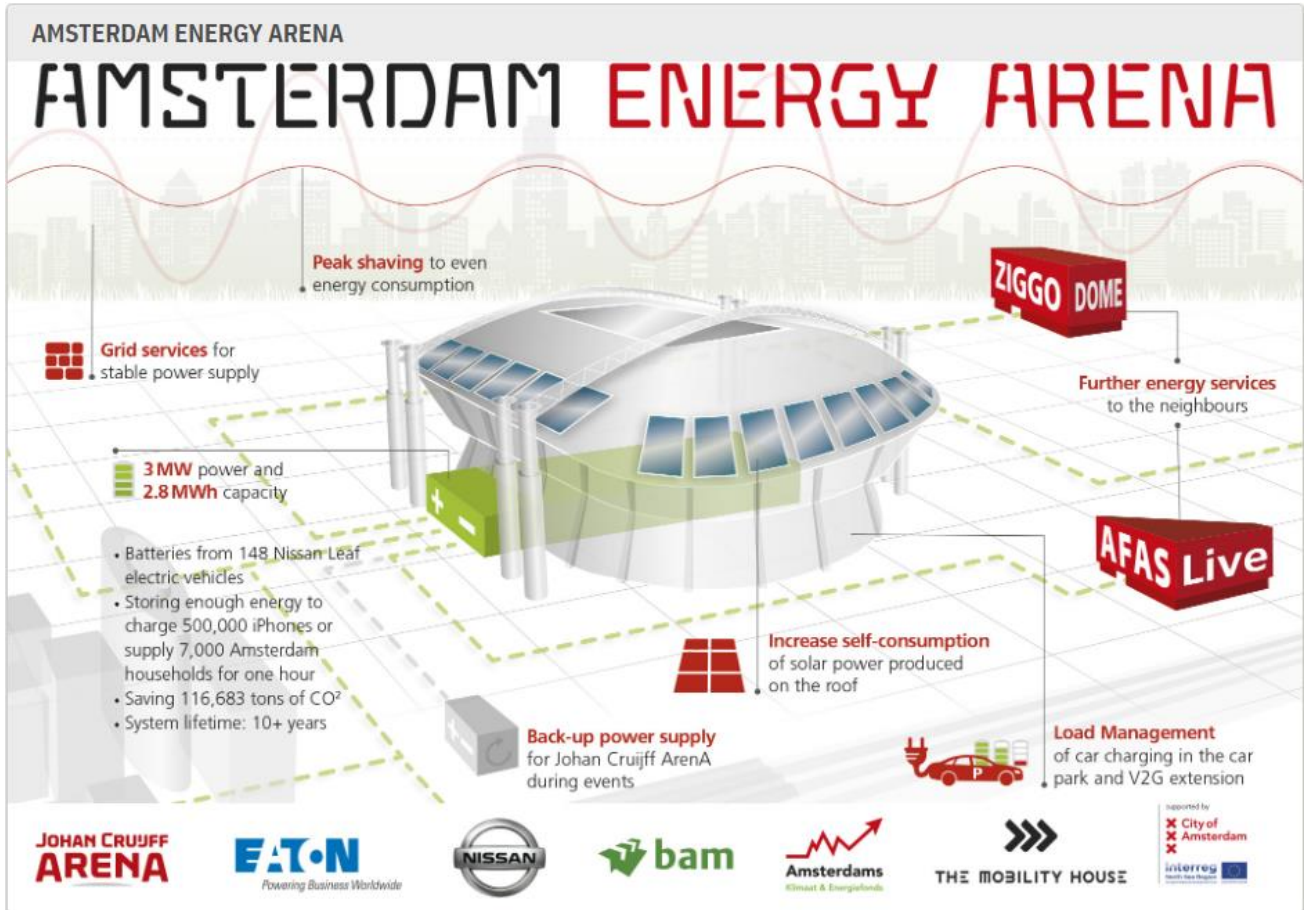

Figure 8: The Amsterdam Energy Arena and its partners [2]

The new services by the static battery and the EV chargers and V2G-unit are all managed by The Mobility House in Munich. As can be seen in the figure below, they have made an interconnect module to optimize and control the different services.

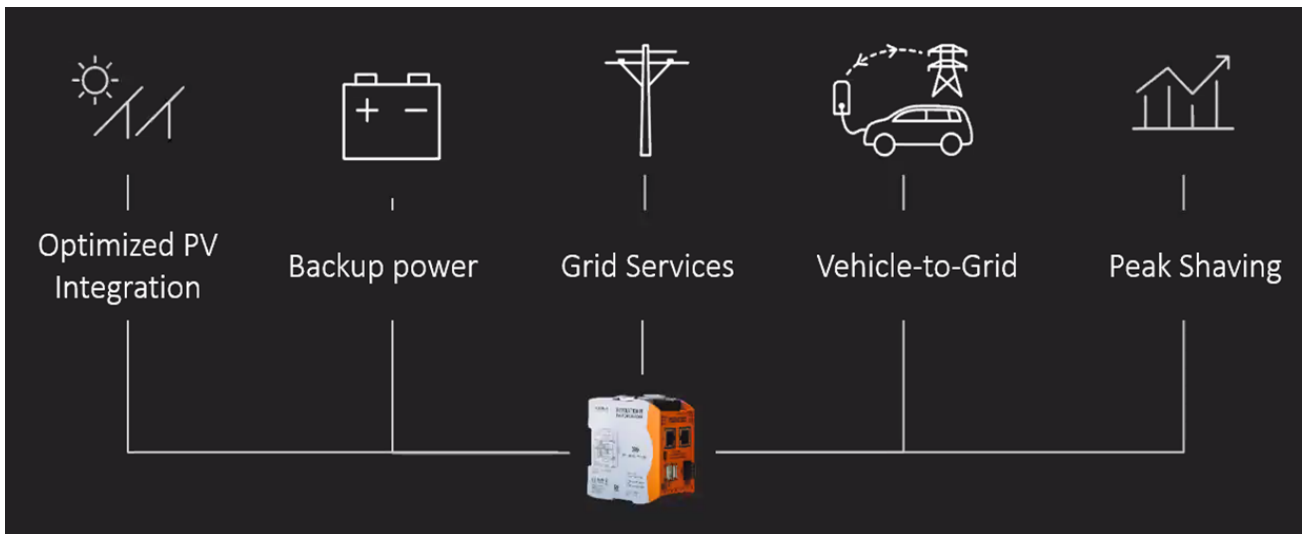

Figure 9: Control module of The Mobility House (picture provided by The Mobility House)



2. Data collection and processing

Data is collected and processed on different levels and by different parties. The measurements of total electricity demand and PV production are managed by BAM, whereas the new system components such as the 3 MW static battery and the EV/V2G chargers are managed by The Mobility House.

2.1. Total electricity demand and PV production

The total energy demand of the JC Arena, and the PV production are measured by electricity meters managed by BAM. For 2017 and 2018 monthly totals are provided. But as in 2018 the solar inverters were replaced in the period April-August no (good) data is available for that period. In 2019 the FCR with the static battery started, and for control and management The Mobility House needed a connection to the electricity meters but all connections were already occupied. By disconnecting the JC Arena server no data could be extracted for a while. New electricity meters will be installed to process data to the JC Arena server but for installation all of the JC Arena must be disconnected from the grid and this has to be done in an eventless period.

As for 2019 no good dataset is available, data of 2017 is used in this report as a base for electricity demand and PV production.

Total energy demand in 2017 was 8,610 MWh (8.61 GWh). Total PV production was 857 MWh, of which 648 MWh (76%) was used locally (8% of total demand), and 203 MWh was exported to the public grid. The totals per month are shown in Figure 10. Energy demand is highest during the winter period, and of course solar production in summer. And even if PV production is much lower than demand, there are moments with a surplus of solar going to the public grid. This is caused by a mismatch between demand and production, and because the PV system is connected to just 4 of the 10 transformers.

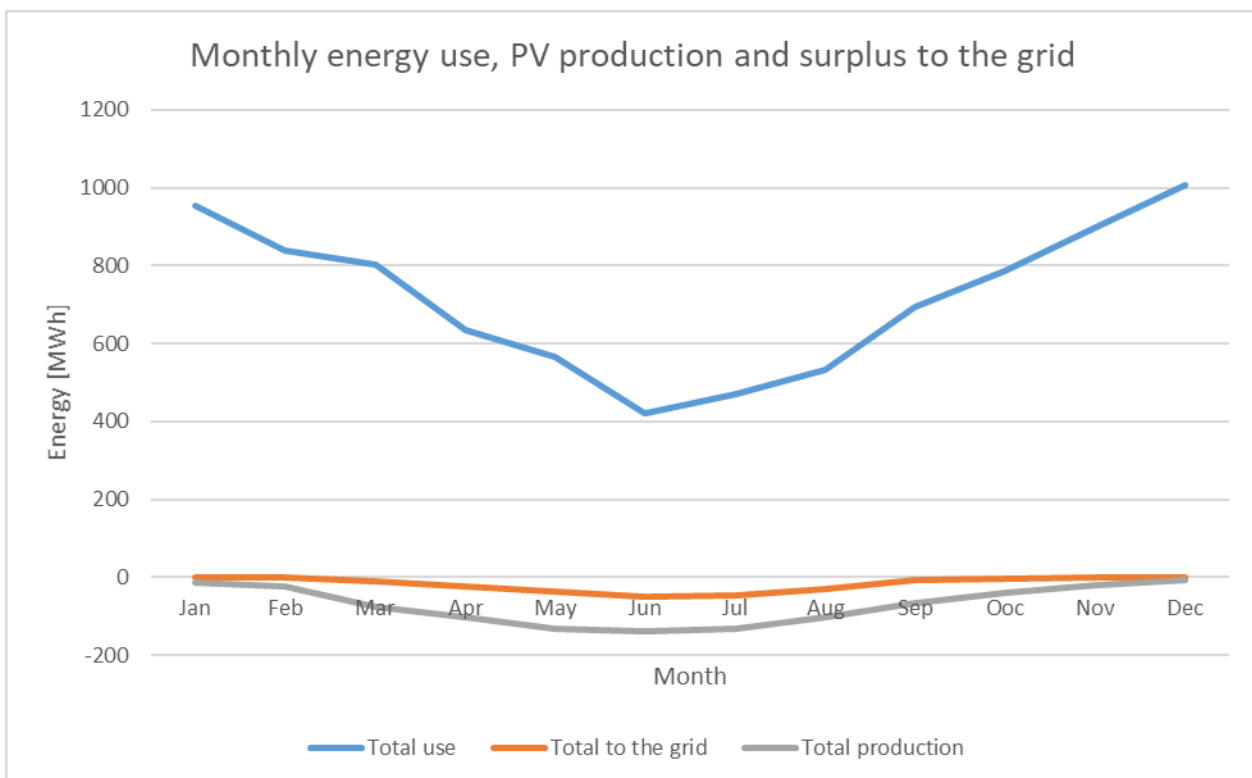

Figure 10: Energy use and production in 2017





Figure 11 shows that the energy demand is not equally distributed over the 10 transformers. Some of the transformers (B3, A3, B4 and A2) have a (much) lower energy demand in summer, others have a more constant demand over the year.

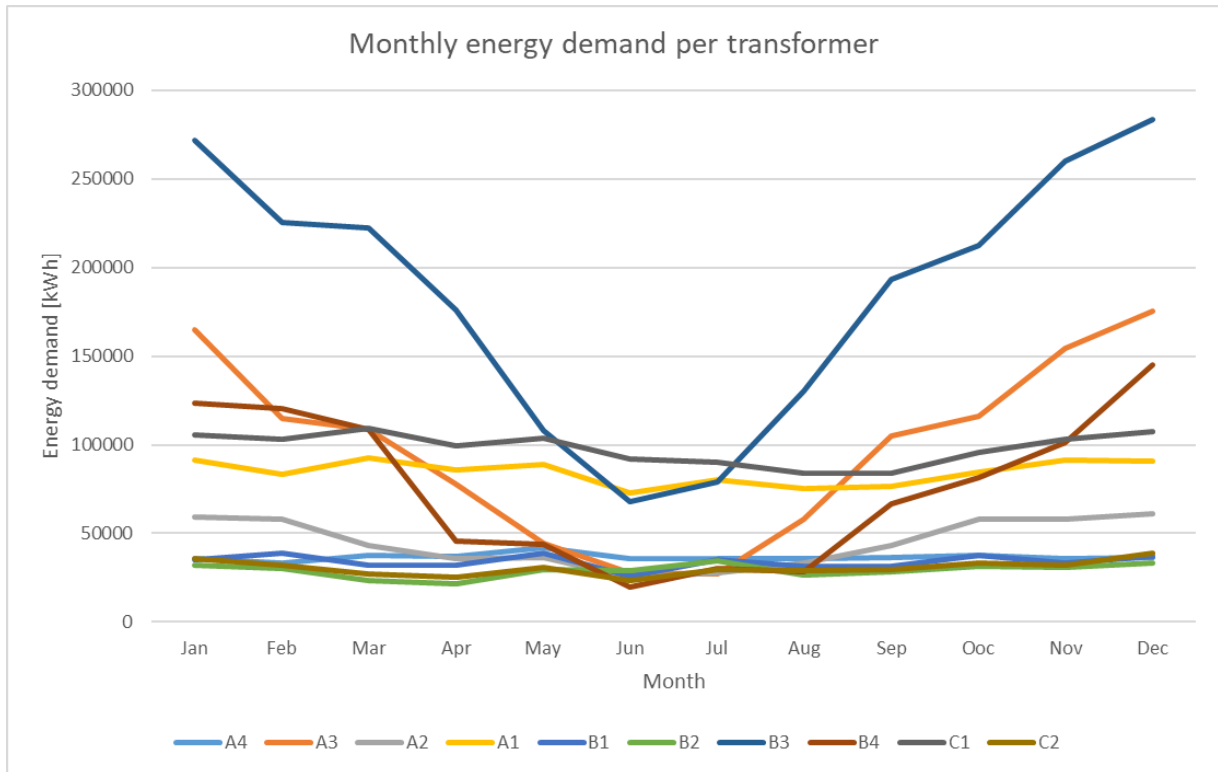

Figure 11: Monthly energy demand per transformer, 2017

The monthly solar production is also not equally distributed. As can be seen in Figure 1, the solar panels are all around the JC Arena, and the panels in the north will produce less than those on the southside. This gives a different energy production, see Figure 12.

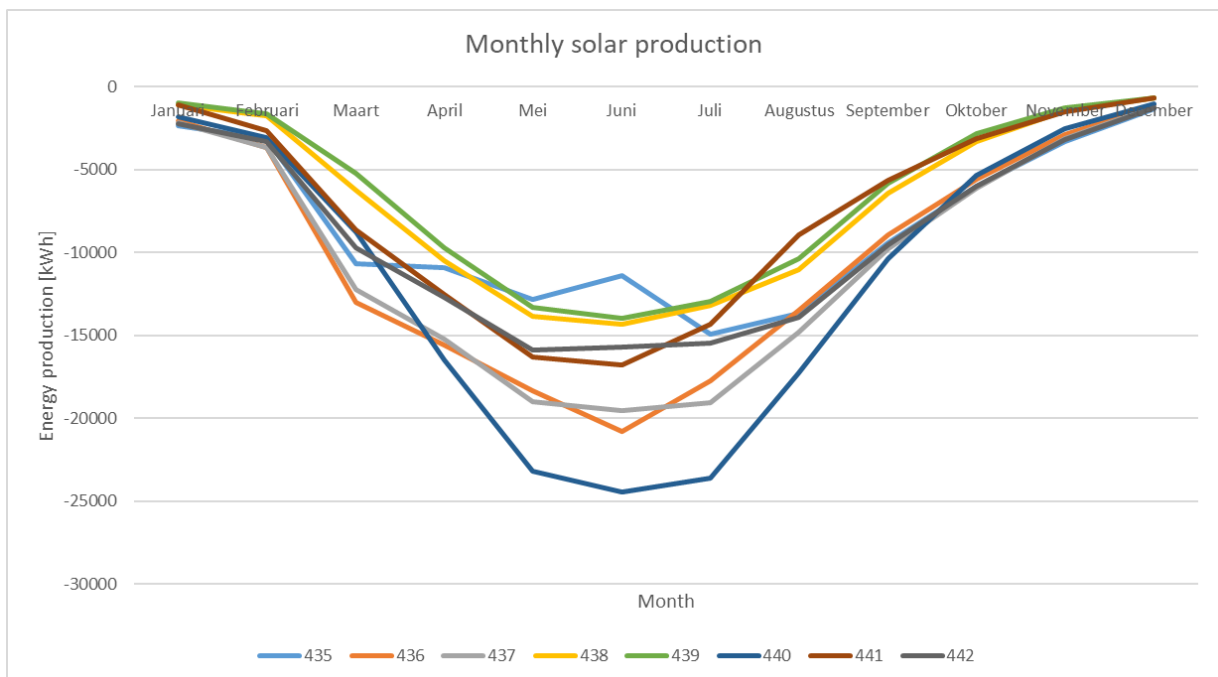

Figure 12: Solar production per inverter per month, 2017





As a result of both demand and production not equally distributed, the surplus to the grid shows also big differences, see Figure 13.

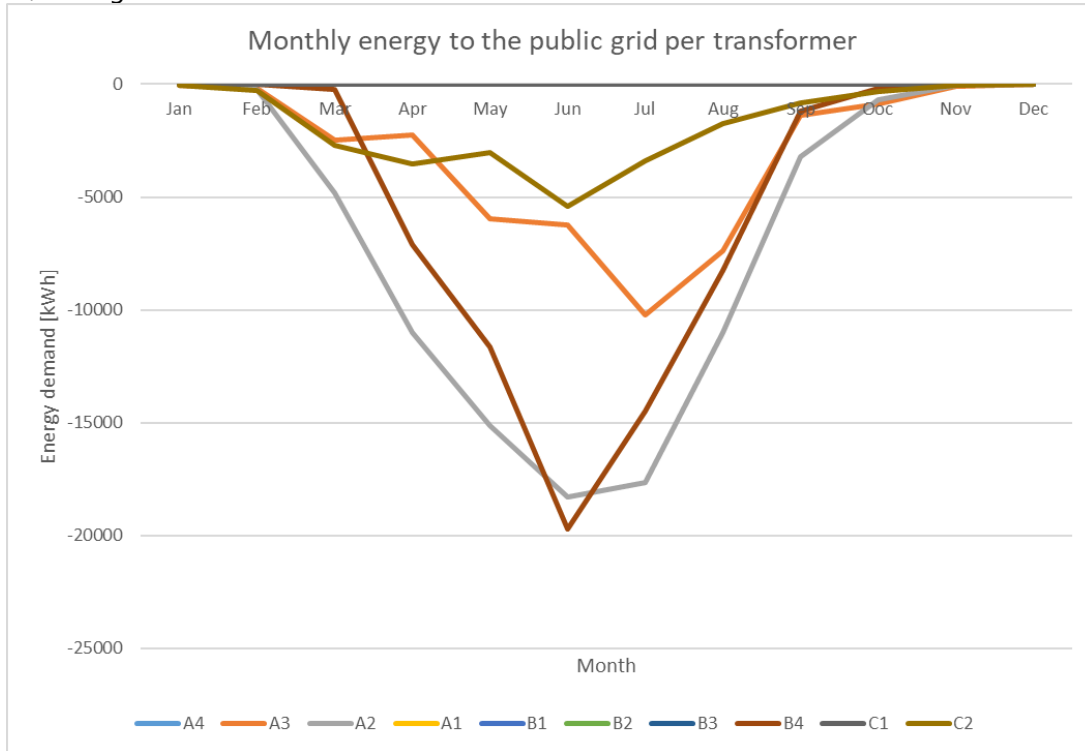

Figure 13: Surplus of solar energy delivered to the public grid, 2017.

When comparing the surplus of energy going to the public grid with total PV production, Figure 14, 36% of solar is not used locally in June, giving opportunities to increase local use.

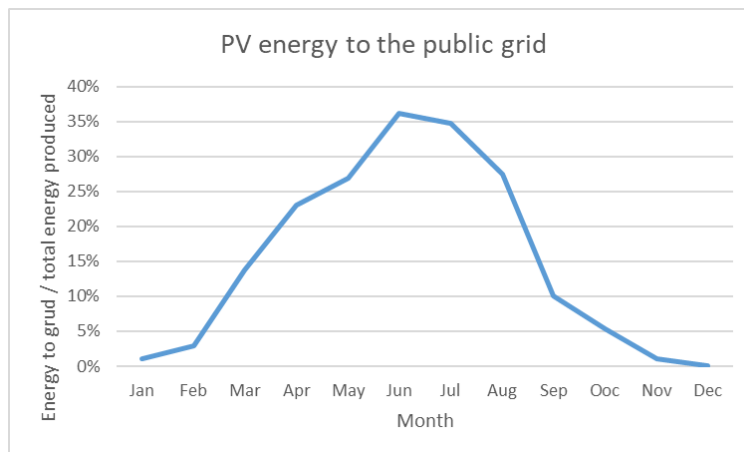

Figure 14: Total surplus of solar energy delivered to the grid relative to total solar production.

2.2. Static battery, EV chargers and V2G unit

The 3 MW static battery, EV chargers and V2G unit are managed and performance is measured by The Mobility House. Within the Seev4-City project the main research questions where:

- Is use of 2nd life batteries possible?



- Are the energy services possible and reliable?
- What savings are possible (energy, CO₂, financial)?
- What are interesting business models?

Use of 2nd life batteries

At the moment of realisation there were not enough 2nd life EV batteries available, so only 40% of the 148 EV batteries are 2nd life. The old batteries showed a different behaviour as the new ones and this combination gave some real problems in controlling the whole battery, and the power was below 3 MW. With the right adjustments it became possible to provide the full 3 MW for at least one quarter of an hour, what was necessary for the FCR services.

Providing services

The five intended services are given in Figure 9:

- Optimized PV integration
- Backup power
- Grid services - FCR
- Vehicle-te-Grid
- Peak shaving

FCR services started January 2019 with 2 MW. Application, and earnings, for these services is per MW, so it was very important for the JC Arena to have the full power of 3 MW available. Figure 15 shows for some days in November 2019 the battery power. FCR services are per day, so when the battery is used for FCR it cannot be used for one of the other services. For FCR, the battery SOC is 50% as default, to have the possibility to give power to the grid, as well to take power from the grid.

On days with big events in the JC Arena, the battery is used for backup power and then the SOC has to be 100%. So when going from FCR to backup, the battery has to be charged as can be seen by the negative power at the start of November 19. By the end of that day, the SOC has to go back to 50% for FCR the next day, as can be seen by the discharging at the end of November 19. The same pattern is visible at November 23. And although the events do not take a whole day the battery cannot be used for FCR these days as FCR is per day. There are plans to change the FCR to 4 hour periods, making it possible to earn more money.

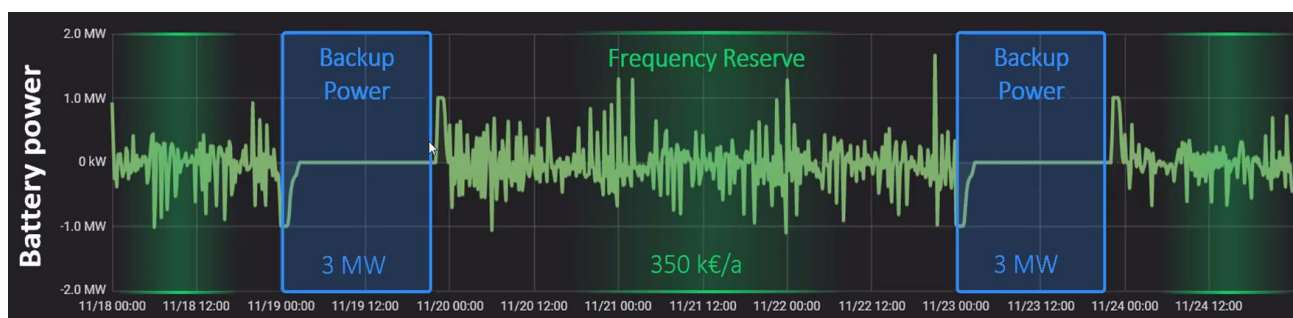

Figure 15: Example of FCR services and backup power (results by TMH).

When used for backup at big events, peak shaving is possible with the 3 MW BESS. This is not practised yet because of the lack of events by corona measures, but it is calculated by The Mobility House that 10% peak power reduction is possible. See for example Figure 16, the day with the highest power demand in 2017. This was on December 10, during the football match between the national top two teams Ajax and PSV. This means a full stadium and maximum use of the electrical installations. In backup, the battery should be available to provide power for 3 hours, so before, during and after the match. Figure 16 gives the 15 minute values of the total power demand. The peak is around 16:45, the start of the match, but is lower before and after. This gives the opportunity for peak shaving: so before the match the full energy of 2.8 MWh must be available, but as time goes on, less energy is needed to have the possibility to provide backup up to the end of the 3 hour period. So

some of the energy in the battery can be used to provide 10% of the power at 16:45, giving a peak reduction of 10% on the maximum peak demand.

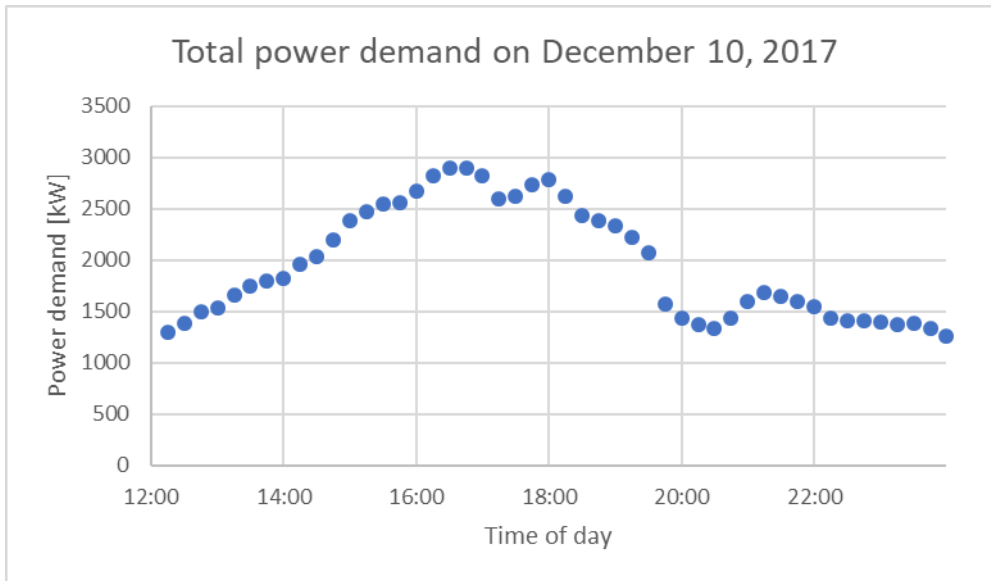

Figure 16: Total power demand in the afternoon of December 10, 2017.

By the end of 2019 a V2G unit was installed at the JC Arena. This unit together with a Nissan Leaf was used for FCR services for one week in December. This worked well and achievable revenues were € 50 in total (between Dec 19, 14:00 and Dec 27, 3:30), see Figure 17.

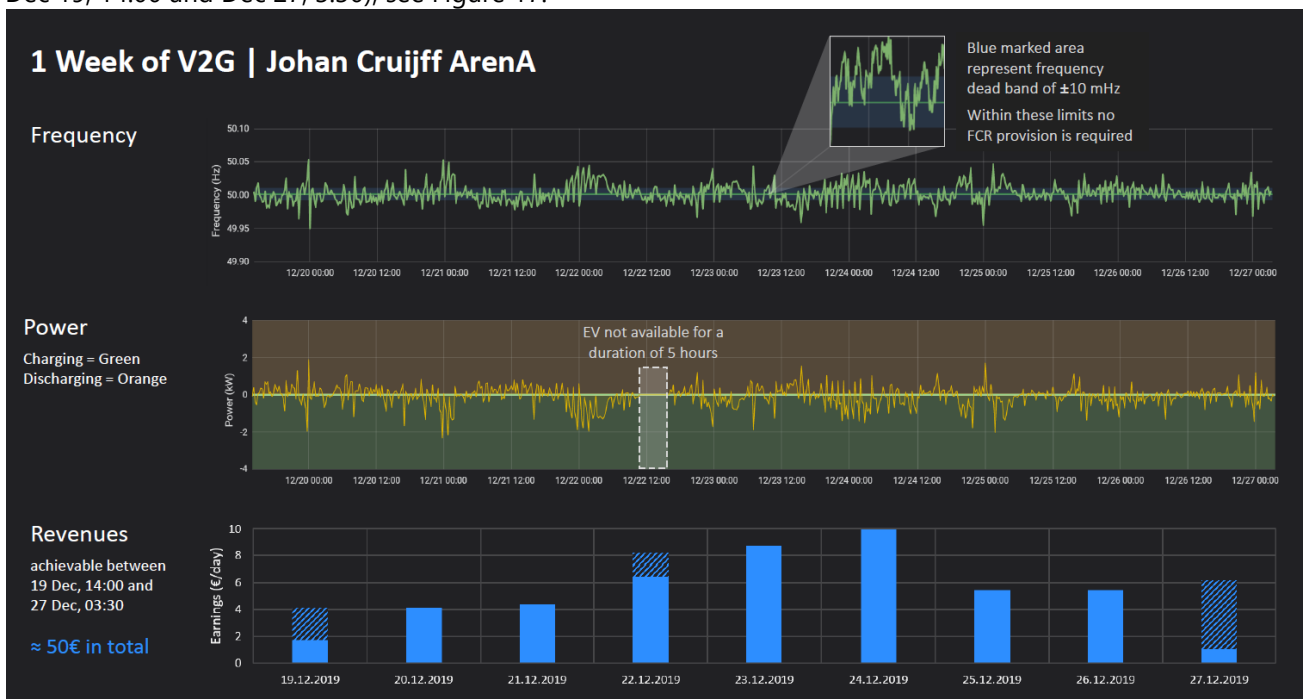

Figure 17: FCR with the V2G unit for one week in December 2019 (results by TMH).

The optimisation of PV integration becomes possible with the flexible power demand control of the EV chargers.



3. SEEV4-City Results – Key Performance Indicators (KPIs)

3.1. Methodology (summary)

Each of the SEEV4-City pilots adopt different system components and have their own approach within its system boundaries. They do not all use the same combination of components but are applied in different combination variations. The SEEV4-City project recognised the potential value in identifying the benefits of individual energy system components (such as PV, BESS and EV battery as storage) for design decisions for a specific location in relation to the project's main KPIs, for CO₂ and Energy Autonomy in particular.

The project has therefore chosen to define several sub-indicators for KPIs A and B for the purpose of capturing potential additional insights in relation to CO₂ and Energy Autonomy objectives and the role these different components may play. The methodology for calculating their contributions is described in more detail in the project's KPI Methodology Report [3]. The identified sub-indicators within the methodology are:

KPI A – CO₂ reduction

- CO₂ related to baseline demand
- CO₂ related to use of battery: EV
- CO₂ related to use of battery: BSS
- CO₂ savings by PV production
- Zero Emission kilometres increase

KPI B – Energy Autonomy

- Self-consumption
- PV to Baseline Demand
- PV to EV
- PV to BSS
- PV to Grid

For **KPI C – Grid Investment Deferral**, the methodology does not narrow itself to the specific pilot site only, but instead looks at the impact potential of the chosen V4ES solution of the location's system design within the regional grid context (where the pilot is).

Relevant results for the combinations used at the JC Arena are highlighted below.

3.2. Baseline and Final measurements

3.2.1. Component data requirements

The requirements are as described in the project's KPI Methodology Report. For the JC Arena the year 2017 is used as reference, as this is the year with the most relevant data available. For CO₂, main measurement are on total energy demand, PV production and electricity charged by the EV. For CO₂ savings by FCR the 3 MW of the BESS is of importance.



3.2.2. Baseline and Final measurements

Baseline and finale measurements are summarised in Table 1, Table 2 and Table 3.

Table 1: Baseline and Final measurements relating to annual CO₂ reduction

		(i) Initial stage	(ii) End of Project	
		Value	Value	Compared to (i)
A. CO₂ Reduction - total				-2012
A.1	Pilot CO ₂ footprint [ton CO ₂]	3587	1575	-120
A.1.1	CO ₂ related to baseline demand [ton CO ₂]	3987	3987	0
A.1.2	CO ₂ related to use of battery: EV [ton CO ₂]	0	62	62
A.1.3	CO ₂ related to use of battery: BSS [ton CO ₂]	0	0	0
A.1.4	CO ₂ savings by PV production [ton CO ₂]	-399	-399	0
A.1.5	CO ₂ savings by ICE to EV replacement [ton CO ₂]	0	-182	-182
A.1.6	ZE km increase [km]	0	178204	178204
A.2	Grid Services [ton CO ₂]	0	-1893	-1893
A.2.1	FCR – Frequency Containment Reserve [ton CO ₂]	0	-1890	-1890
A.2.2	Battery as back-up services (replacement of diesel generators) [ton CO ₂]	0	-3	-3

Table 2: Baseline and Final measurements relating to Energy Autonomy

		(i) Initial stage	(ii) End of Project	
		Value	Value	Compared to (i)
B. Energy Autonomy Increase				
B.1	Self Sufficiency [%]	8%	9%	1.2%
B.2	Self Consumption [%]	76%	88%	12%
B.3	PV to Baseline Demand [MWh]	654	744	90
B.4	PV to EV [MWh]	0	12	12
B.5	PV to BESS [MWh]	0	0	0
B.6	PV to Grid [MWh]	203	101	-102

Table 3: Baseline and Final measurements relating to Grid Investment Deferral

		(i) Initial stage	(ii) End of Project	
		Value	Value	Compared to (i)
C. Grid Investment Deferral				
C.1	Peak Demand Value [MW]	3.0	2.7	-0.3 (10%)

3.3. KPI result conclusions

3.3.1. CO₂ Reduction or Savings

The JC Arena is buying its electricity from a wind park in The Netherlands, so CO₂-emissions are low. To make the CO₂ savings potential relevant for locations without this green electricity, we made the calculations as if the electricity is from the national mix. From the ENTSO-E database we use the 2019 data.

By far the most CO₂ savings are realised with the FCR services. The 3 MW BSS is used for about 335 days a year. With the calculation method in the Seev4-City KPI Methodology document this results in emission savings of 1890 ton CO₂/year.

An additional emission saving of 3 ton CO₂ is possible when the diesel generators will be replaced by the battery (this is not done yet because of safety regulations and permits given to the JC Arena).

The 14 EV chargers save on ICE emissions. In the first months there was an average charging demand of 13 kWh per session. Extrapolating this to a normal year we calculate with two charging sessions per day, making the total charging demand 133 MWh per year. With 466 gr CO₂/kWh (Netherlands electricity mix 2019) this is an extra emission of 62 ton CO₂. Total km driven with these 133 MWh is 825,217 km, so total emission savings by ICE to EV replacement is 182 ton CO₂/year, and net savings are 120 ton CO₂.

For the ZE km: 12 MWh is coming from the local PV system, the other 121 MWh from the public grid. That public grid had 14% renewables in 2019, giving a total ZE km of 178,204 km.

3.3.2. Energy Autonomy increase

In 2018 new inverters for the PV systems are installed and connected to more (6 instead of 4) transformers so more PV production could be used locally. As 2019 data is not available yet, we assume 50% less energy going to the grid, 102 MWh in 2017 numbers. This gives an increase in self-sufficiency of 1.2 %, and the new self-sufficiency is 9%. Self-consumption increases with the same 102 MWh, becoming 88%.

12 MWh of the PV energy will go to the new EV chargers, on a yearly base. So remaining increase of PV to baseline demand is 90 MWh.

3.3.3. Grid Investment Deferral / peak reduction

With smart use of the battery energy when used for backup power, a peak reduction of 10% is possible, so 0.3 of 3 MW.

For the 14 EV chargers, the total power limit can be set flexible. In the beginning of 2020, this limit was set to 150 A, giving 103.5 kW of maximum power. Compared to the total maximum power of 308 kW (14 * 22), this is a peak reduction of 66%. This peak reduction can be made dependable on the amount of PV produced, optimising the local use of PV energy. At 210 A (local infrastructure design, 145 kW), the peak reduction is still 47%.



4. Cost-Benefit Analysis

4.1. The stationary battery energy storage system (BESS)

The stationary battery energy storage unit enables the JC Arena to do FCR (Frequency Containment Reserve). In addition, The JC Arena also implements peak shaving using the stationary battery storage unit. As such peaks are flattened, and there is less volatility on the grid. This is beneficial for TSO TenneT because they have to deal with less volatility in the grid, and see more frequency stability, so they do not have to purchase from coal or gas power plants. TenneT pays money to the JC Arena for the FCR service provided with the storage unit. All FCR auction results are published on the dedicated web page. The average price in 2019 was 2,653 €/MW/week. The BESS was operated on the market most of the year, with the exception of event days / weeks. The auction was based on a 1-week bid until 30th June 2019. After that, daily bids were introduced. From 1st July 2020, the auction is even more dynamic providing 6 results for each day (4-hours periods).

Costs of the pilot occurred for the purchasing of the stationary batteries for the big storage unit. Another party (The Mobility House – TMH) has set up the battery control system and created all interfaces required for applying the use cases. TMH's benefit was that they gained experience and that they can use the project to showcase their technical possibilities to clients, which they frequently invite to the JC Arena for viewings. As a compensation for the daily bidding of BESS capacity on the FCR market, system monitoring and reporting to TenneT, TMH also receives a remuneration that is based on the monthly FCR revenues. The exact costs of the Operational Pilot are arguably of no consequence to the SEEV4-City project outcomes on business models – what matters is whether a business case can be made or not. There are many variables that only apply to this specific case and those exact details will not help any future projects. According the JC Arena and TMH the cost for stationary battery energy storage is roughly 650 k€ per MWh. This is close to what the Operational Pilot paid but because of the additional use cases such as Back-up power, integration of V2G and FCR services, the real cost in this Operational Pilot was about 50% higher, especially in terms of hours put in by each of the partners. Break even should be after 10 years for the business case.

Table 4: Battery energy storage costs and benefits for the JC Arena.

Stakeholders	Type of organisation	Costs	Benefit: revenue (income) OR cost savings
<p>Amsterdam Energy Arena</p>	<p>Real estate company - events location</p>	<p>The price of the 148 EV Nissan Leaf batteries – a mix of predominantly new and 40% second-life.</p> <p>The BESS was purchased by Amsterdam Energy Arena. Prices were competitive but within market range.</p>	<p>Emergency back-up energy provision (could / would replace diesel generators, so an increase in sustainability and CSR-related publicity gains from that to position better in the market (including as an internationally trading consultancy company).</p> <p>Peak shaving: reduced electricity bills for the JC Arena.</p> <p>Additional benefit: ability to undertake grid-facing energy services, with income payments from TenneT for FCR.</p>





TenneT	TSO	All FCR auction results are published on https://www.regelleistung.net/ext/?lang=en . The average price in 2019 was 2,653 €/MW/week. The BESS was operated on the market most of the year with the exception of event days / weeks. The auction was based on a 1-week bid until 30 th June 2019. After that daily bids were introduced. From 1 st July 2020, the auction is even more dynamic providing 6 results for each day (4-hours periods).	Benefit: less volatility in grid (peak shaving and FCR) cost savings: lower costs to stabilize demand and supply, less investments in grid needed.
The Mobility House	(Trans-nationally active) IT/ smart energy management company	Installation of storage unit; development and application of algorithms.	Benefit: better reputation; showcase; experience gained. Income: share of FCR revenues. Possibly increased demand for their services from (potential) clients.
Eaton	Battery storage system innovation/ provider	Eaton contributed some extra work as part of the innovation partnership. None that are not covered by their income, according to JC Arena	Benefit: Reputation and development of expertise; Income: Eaton was paid for the BESS equipment and annual maintenance.
Amsterdam Climate & Energy Fund (AKEF)	(Municipal) Investment fund	AKEF acquired an equity share in Amsterdam Energy Arena and provided a loan for the BESS debt financing.	AKEF acquired an equity share in Amsterdam Energy Arena and provided a loan for the BESS debt financing.
Indirect stakeholders:			
City of Amsterdam	Local municipality	According to JC Arena, there were no costs incurred by the City of Amsterdam.	Benefit: contributes to Amsterdam's climate goals (Amsterdam Climate Neutral 2050 programme).
Dutch Government	Central government		Benefit: contributes to the Netherlands' climate goals.

4.2. The V2G facility

The JC Arena provides two-way EV charging poles in their parking garage. When customers such as football supporters or concert-goers come to the JC Arena for events with their EVs, they can offer to supply their battery's energy to the JC Arena's grid, so that the JC Arena can cover their peak energy demand (which occurs during these events). Benefit for the event customers in the JC Arena parking deck (with 300 spaces for skybox owners and VIPs) are still to be decided and may be reduced parking fees or perhaps alternatively publicity for the EV owner participants instead of a monetary value. Parking fees are for the city who own the parking garage (with 2,000 spaces). JC Arena can provide free catering or publicity for participants or another non-monetary compensation.



Table 5: V2G-related costs and benefits for the JC ArenaA.

Stakeholders	Type of organization	Costs	Benefit: revenue (income) OR cost savings
Amsterdam Energy ArenA	Real estate company	Provision of parking space and investment into/costs of charging poles.	Benefit: peak shaving; more energy supply during peak hours.
The Mobility House (TMH)	Charge point operator and smart charging and energy management system operator.	Cost for V2G charger €20k and software development costs of €30k.	Reimbursed for part of the development costs by JC ArenaA and SEEV4-City. Monthly fee for CPO services & maintenance.
EV owners	Private owners/ users	Cost to recharge their EV's battery (elsewhere).	Income: this may be a feed-in fee paid to them or reduced parking fees.
Liander/ Alliander	Distribution System Operator	Cost savings: they need to invest less in LV cables and transformers/ the distribution system.	
City of Amsterdam	Provision of parking spaces: In the parking garage underneath the stadium are 2,000 parking spaces owned by the city. TMH are participating in a project to install 20 V2G chargers there that will be connected to JC ArenA/storage.		

For the coming years more V2G units are planned. Several services are possible, like grid stabilization, peak shaving and battery backup [4]. In [4], several scenarios were made for peak shaving, the result is shown in Figure 18 (the peak value is above 3 MW when not taking the average of the 10 transformers for every quarter of an hour, but only the maximum values. For example, from 15:30-15:45 the average power during 15 minutes was 2666 kW, the sum of the minimum power values 2291 kW, and the sum of the maximum values 3231 kW).

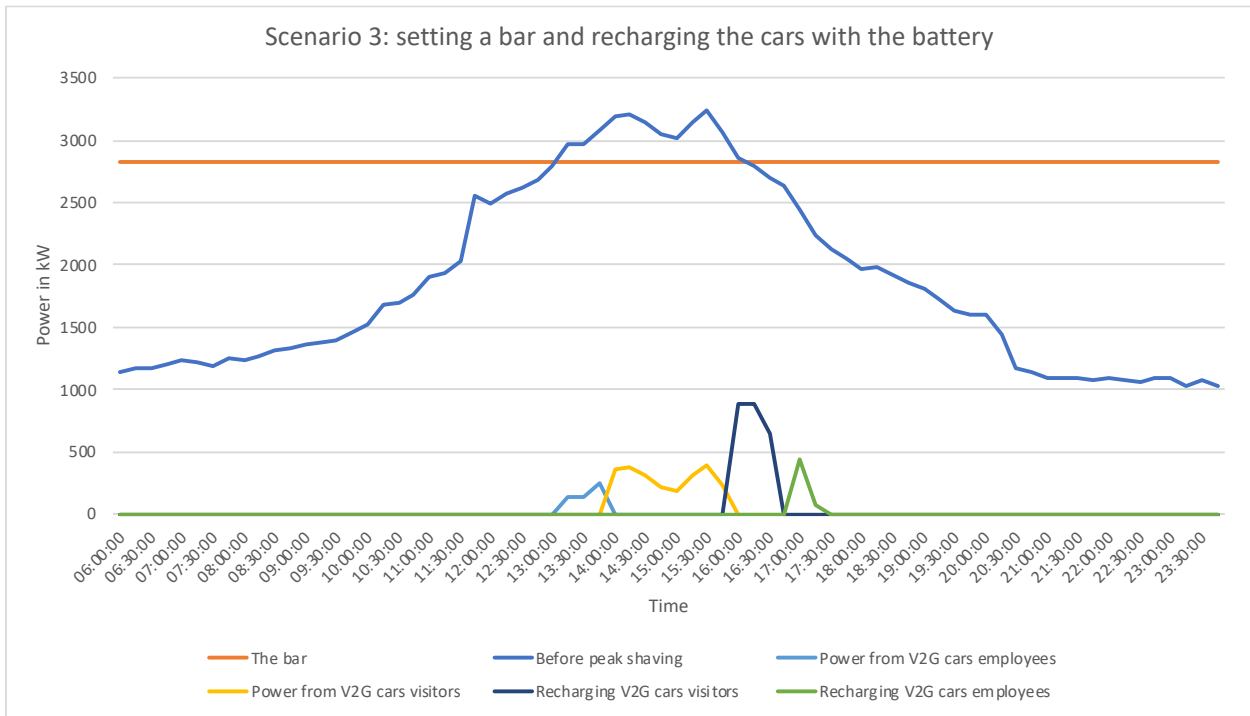

Figure 18: Possible peak shaving with V2G functionality.

The graph shows six lines. The blue line is the peak that was drawn during the football game on 29th January 2017, the match started at 14:30. No adjustments were made yet. A maximum powerline is set, in this case the orange line at 2831 kW. The EV of the visitors are available for a limit amount of time, here it is assumed they arrive half an hour before the start of the match (so at 14:00), and leave three quarters of an hour after the match (so at 17:00). So before 14:00 some of the power has to come from V2G cars of the employees, this is the light blue line. Then the yellow line shows the power that was supplied by the V2G cars from the visitors. The dark blue shows the power that is supplied to charge the V2G cars from the visitors so they can leave with a full battery. Finally the green line shows the power that was supplied by the battery to the V2G cars from the employees.

Before peak shaving, the maximum power peak was 3231 kW. After peak shaving the maximum power peak is 2831 kW. This corresponds to the 400 kW that can be supplied by 40 V2G cars at 10 kW each from the visitors during the game. Therefore, the peak can only be reduced as much as the V2G cars from the visitors can supply.

Another option in [3] is the use of V2G for backup. The graph below, Figure 19, shows the effect with the use of 0, 20, 40 or 60 EV with each a battery of 50 kWh, and power outage starting at 14:30.



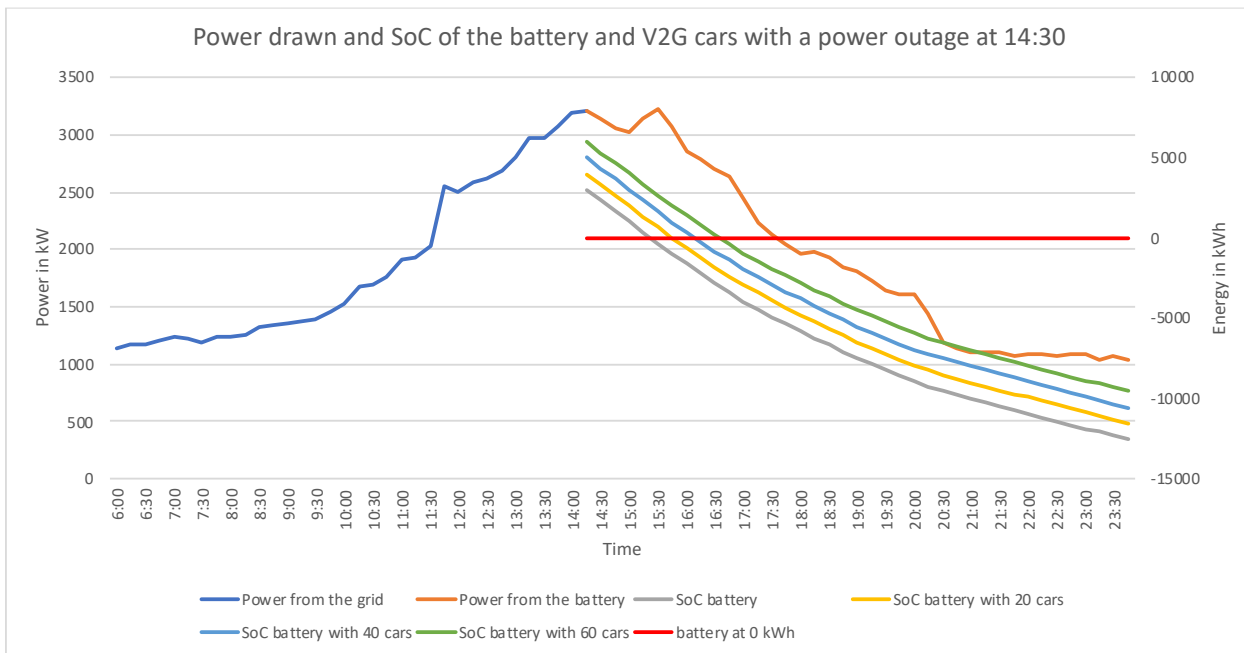

Figure 19: Use of V2G for backup.

The blue line is the power that is supplied by the grid. The moment it transitions in orange is the moment that there is a power outage (14:30 on the x-axis). The values of these lines can be read on the left y-axis. On the right axis is the energy in the battery. The grey line is the energy in the battery without any V2G cars. The yellow, light blue and green light respectively are the energy in the batteries with 20, 40 and 60 V2G cars. The red line makes it easier to locate the moment the SoC of the battery and the V2G cars is zero. So with 60 cars, 50 kWh each, the amount of electric energy is doubled, and there is one hour more of backup power, and the end of the match can be reached.

In [5] a study for a possible business case for peak shaving with V2G was done. A SWOT analyses was made as shown below:

Strengths

- The Popularisation of vehicle to grid charging. The Johan Cruijff Arena is a great platform to help popularize the technology beyond the controlled pilots and research its currently confined too.
- The established network. The Johan Cruijff Arena has been involved with vehicle to grid and other electricity storage solutions for several years. This means that a lot of partners have been found that can help with the financing, maintenance and development of the technology.
- The infrastructure is in place. The Johan Cruijff Arena has all the infrastructure in place to implement V2G. this included ample parking spaces and an electricity network flexible enough to accommodate the additional chargers. Furthermore the 3 MW battery system that has already been installed has given insights in how to use battery storage to its maximum capacity.

Weaknesses

- Limited costs reduction. The cost reduction following peak shaving are only €337,00 a month this isn't enough to cover the investment cost of the chargers.
- Takes up valuable parking spaces. The Johan Cruijff Arena's underground parking garage has space for 2500 vehicle's however this will be limited when bidirectional chargers are installed as these can only be used by participants with the a V2G compatible car.

Opportunities

- The EV market is growing. The market for EV's is growing rapidly in the Netherlands on top of that the EV market in the region Amsterdam is expected to grow even faster.
- Target Audience highly involved. The target audience consists of early adopters and innovators these are people willing to participate in the development of new technologies and are willing to take some risks.



- Flexible use of bidirectional chargers. The chargers could be used as a measure to reduce the peak demand of the stadium but could also be used for grid stabilisation. This flexible use of the technology means that even if the peak shaving doesn't prove viable in the long-term other options are available.

Threads

- Limited implementation of vehicle to grid. Currently the Nissan LEAF is the only EV on the market that is V2G compatible later this year (2020) the Honda e [24] will join the LEAF with its V2G compatible battery system. This however is still a long way of from full implementation and with not one European car manufacture opting for vehicle to grid systems this still seems a long way off.
- Tesla not investing. Tesla is a market leader this means that their unwillingness to participate in V2G could halt any progress in the development of the technology.
- Untested technology. The technology vehicle to grid is still a new technology that has only been tested in controlled environments. This could result in a lot of unexpected problems slowing down progress and increasing costs.

From the external analysis of the SWOT analysis a scenario cross can be constructed using to drivers of the technology. These drivers are either opportunities or threats but are both considered highly impactful and their outcomes are unknown and volatile. The first driver chosen is the involvement from the target audience this is an unknown as pilots involving the public concerning V2G haven't yet been conducted. The first driver is put on the x-axis in the scenario cross as seen below in Figure 20, the second driver concerns the involvement of car manufactures and is measured as the amount of V2G EV's on the road. This driver has been put on the y-axis in Figure 20.

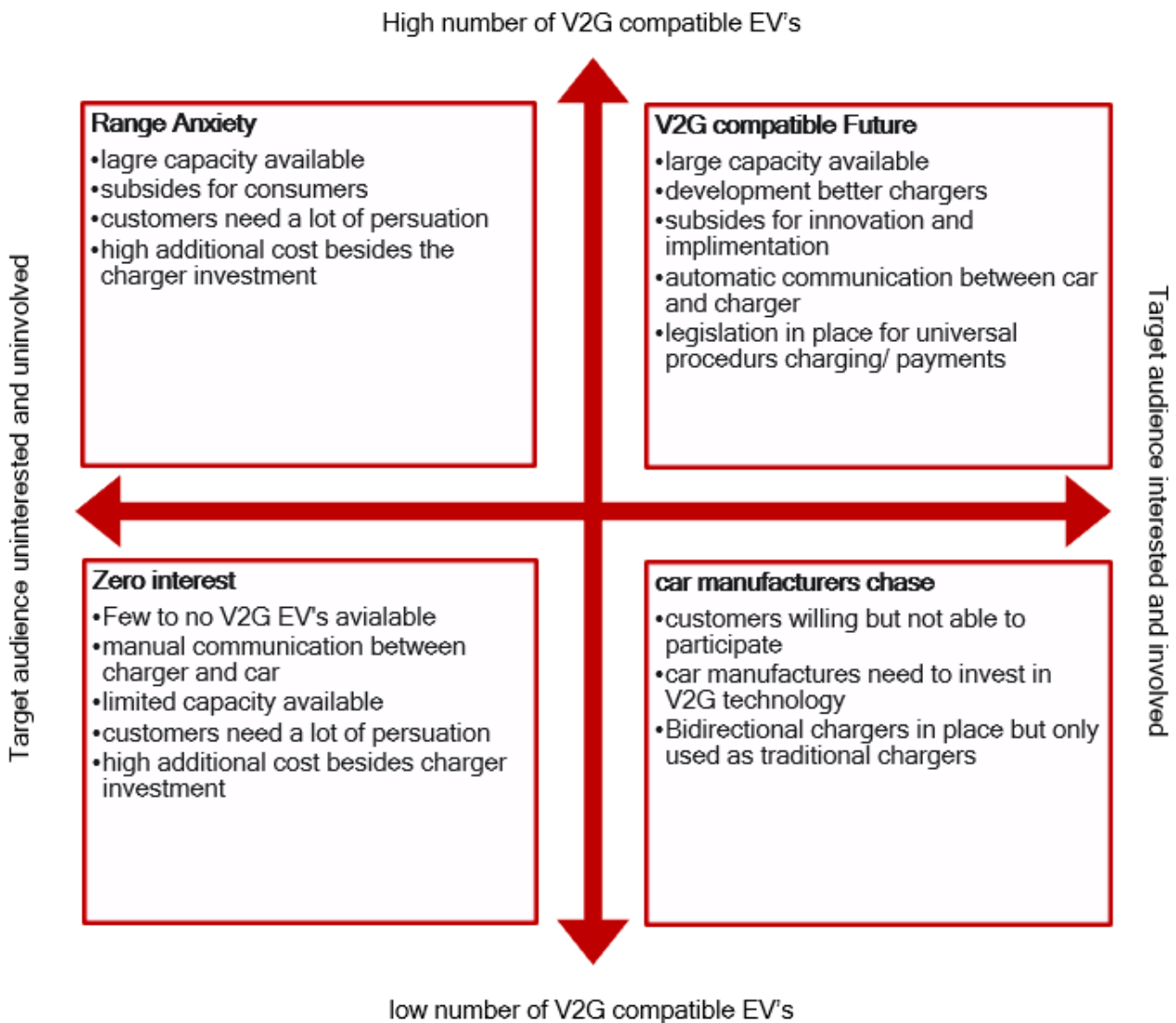

Figure 20: Scenario cross.

Based on the idea from the SWOT analysis, the scenario cross and a value proposition design phase three concepts were made.

1. Reduce waiting lines. Here the EV enter through a separated entrance allowing easy access to the stadium, so circvment long waiting lines making the experience more enjoyable.
2. Free parking space. This concept reduces costs of parking in the JC Arena for the users of bidirectional chargers.
3. Active involvement. This involves customers on a more emotional level by taking advantage of the early adopters will participate and experiment with new technologies.

A decision matrix demonstrates that all concepts are too expensive to implement in the stadium as the price of the chargers is to great and would have to drop in order to make the use of V2G to lower the peak demand viable. If investment costs are ignored the third concept comes out on top as the best solution for the JC Arena.

4.3. Overall business model

The Mobility House aims to implement an overall business model for the JC ArenA with five different value streams:

1. Optimal PV integration;
2. Back-up Power: This is required by Dutch national and Amsterdam local regulations, in case there were to be an electric power outage at the venue – particularly at big events – so as to ensure safe evaluation etc. The diesel generators, their diesel fuel consumption and associated CO₂ emissions can this be replaced;
3. Grid Services: Currently, this is in the mainly targeted at Frequency Containment Reserve (FCR) by having pre-qualified and now bidding to TenneT, the TSO active both in the Netherlands and Germany on the European power markets. This will utilise the stationary battery storage unit in the main;
4. V2G: JC ArenA did lease 2 BEVs (Nissan Leafs) and showcased two V2G use cases in December 2019:
 - a. JC ArenA: during a public launch event on 9th December 2019, a Nissan Leaf was discharged automatically, using the smart charging control software from The Mobility House. The EV battery supplied 10 kW power to the stadium, thus powering the meeting room and facilities needed during the launch event.
 - b. Vehicle-to-Grid: During the Christmas holiday period, between 20 and 27 December 2019, a Nissan Leaf was connected to the bidirectional charger for a whole week and provided continuous grid services. This demonstrated the potential of bidirectional EVs to support the future energy system in balancing volatile energy production from renewable sources. It also demonstrated the real-life economic potential. The value of the grid services provided within this one week equalled 50 Euros (based on the reference auction price for frequency response services during that period). It also demonstrated the key challenge of V2G: On 22 December, for a period of 5 hours, someone unexpectedly took the Nissan Leaf for a ride and interrupted the grid service. In the future, large numbers of EVs connected to a grid and aggregated by energy service suppliers will be able to absorb such fluctuations and provide for a stable contribution of grid services. JC ArenA did install a number of V2G chargers, which was a procurement challenge as the first set obtained did not function and had to be returned to the provider. The second batch proved to be functional, but Covid-19 lock-down restrictions have prevented further use by visitors since March 2020 and during the now postponed European football championship, as well as other major games.
5. Peak Shaving: Here the increased self-consumption/ energy autonomy of the JC ArenA will reduce the amount of electricity needed from the grid during events. The objective is a reduction of peak power by approximately. 10%. This will lead, within the Dutch system, to reduced electricity bills for the JC ArenA, by approximately. €10,000 p.a..

The intelligent software control developed by The Mobility House enables electric cars of stadium visitors – given the owners' consent – not only to receive power from the charging station, but also to feed electricity back into the stadium's electrical infrastructure. "Vehicle-to Grid" is an important milestone on the way to a more sustainable energy supply. In the future, over 2,000 parking spaces at JC ArenA (owned and managed by the City of Amsterdam through their Parkeergebouwen Amsterdam) will be successively equipped with intelligent EV charging infrastructure.

The stadium will thus be expanded into an energy hub – using electric car batteries to help store electricity from renewable energies and thus relieve the power grid. The energy from the cars reduces the amount of electricity drawn from the grid when the stadium's electricity load is extremely high, for example during a Champions League game. As a consequence, electricity bill costs are reduced. In addition, this energy supplements the battery storage, which is available as an emergency power supply for the JC ArenA in the event of a power failure (power outage).

The Amsterdam fans thus have the unique opportunity to support their club also in the form of providing electrical energy. In this way, they also stabilise the electricity grid and promote the use of renewable energies. The system also ensures that the car battery is recharged in time when visitors return home. The use of electric vehicles as an innovative energy source is a system promoted by the European Union and is also in line with Amsterdam's goal of becoming the V2X capital of Europe. The project is the result of collaboration between



BAM, The Mobility House and Johan Cruijff ArenA and is supported by SEEV4-City, an initiative of Interreg North Sea Region and the Amsterdam Climate & Energy Fund.

For The Mobility House, this project represents a further milestone in the intelligent integration of vehicle batteries into the energy system and complements the existing V2G, smart charging and battery storage projects that have been implemented in recent years with partners such as Daimler, Renault, Nissan, Audi and others.



5. Lessons from the different pilot phases

5.1. Preparation and initiation

Connecting the PV system

The PV system was connected to just four of the ten 10 kV/400V transformers. As the energy demand is dispersed over the ten transformers, there is a surplus of solar energy going to grid while there is still energy demand on the other transformers. When connecting a large PV system to a location with multiple transformers, a better analyses should be made of the energy demand per transformer to optimize the local use of the generated PV.

5.2. Procurement

V2X units

Earlier, the JC Arena procured MagnumCap V2X units provided by Enel. However, The Mobility House tested the units and they did not perform as specified. The units stopped reacting to commands from the controller, and MagnumCap was not able to fix the issue (for as yet unknown reasons). One of these faulty MagnumCap units will be studied by KUL to determine why performance was not as expected. Now the JC Arena is replacing these with three EV-tech V2X units, but currently has bought only one V2X unit due to the high unit prices and the available budget. In the request for quotation (RFQ); a delivery time within six weeks was stated, this seemed not to be a problem at the time.

The current prices of these V2X units are very high compared to regular chargers, which may form a barrier for procurement, e.g. JC Arena reports prices of a factor 20 compared to fast chargers. The JC Arena procured their current EV-tech V2X charger one and half year ago, expecting the prices would fall over time and to have an increased number of manufacturers being active in this market. But to date, this turned out not to be the case. Also, other manufacturers do not comply with the standards The Mobility House is looking for in V2X chargers. They have tested multiple V2X chargers and have a set of data they require to receive from the V2X units. One of these requirements is communication with the back-office of the EV to check the temperature of the battery, the State of Charge (SoC) and State of health (SoH) before engaging the bi-directional functionality. Another barrier could be the lead time of V2X chargers, as pilots reported lead-times of 12 to 16 weeks.

Battery storage system

The JC Arena strived to build a BSS consisting only of second-life batteries, but due to their low availability at the time, 40% of the batteries are second life. This is an issue that may be resolved over time when more EV batteries flow into the static battery market for second life usage. The JC Arena aimed to accept second-life battery cells with a State of Health (SoH) of <82%.

5.3. Implementation and installation

Battery storage system

The JC Arena experienced compatibility issues installing a mix of new and second-life batteries. Balancing the second-life batteries with the new batteries proved far more difficult than expected because an older battery is acting different compared to new batteries. During the installation, the Dutch TSO TenneT changed the qualification specifications for FCR services before the launch in June 2018. Consequently, the mix of second life and new batteries could not comply to the new specifications. The new specifications required the battery to be able to load 1/3th (0.3C) for 15 minutes long, and thereafter, 15 minutes on full load (1C). The new batteries could comply with the specifications, but the second-life batteries could not. Above 75% state-of-charge (SoC), the batteries are charging at a lower speed, and the old batteries were reaching over the 75% after the test cycle with the consequence that the full charging speed was not achieved. Eaton and Nissan have resolved this issue by adjusting the batteries, whereby the 3MW qualification for FCR services was delayed for about a half year. Mixing second-life batteries with new batteries could result in compatibility issues and could have been avoided by over dimensioning the design.



5.4. Operation

Data Collection

Energy meters were installed to log and write data of the energy system. However, the meters only allowed four data connections which were occupied already. The management of the Mobility House would be the 5th data connection, but this turned out to be one too many and therefore the system went down when attempting to connect. One connection needed to be freed up, which happened to be the server of the JC Arena which would log data, so the Mobility House could continue managing the energy system in the meantime before replacing the energy meters. These have been procured and are ready to be installed. To install these new energy meters, the system must be disconnected, which requires careful planning due to other activities happening in the JC Arena.

Energy Management

In Amsterdam, the JC Arena has a grid connection licence for 3.4 MW. However, if the 3 MW battery, the 14 fast chargers and the bi-directional charger demand full power (in a situation when there is no solar power available), they are going to exceed this limit. Therefore, the Mobility House collects all the data (building consumption including EV charging, PV energy generation, PCR market) and manages the energy flows between the energy system components and the grid. If necessary, they can reduce the speeds of the fast chargers to reduce the demand and keep under the 3.4 MW limit.

6. Conclusions and Recommendations

6.1. Project and system recommendations

The JC ArenaA strived to build a BESS consisting only of second-life batteries, but due to their low availability at the time, 40% of the batteries are second life. This is an issue that may be resolved over time when more EV batteries flow into the static battery market for second life usage.

The JC ArenaA experienced compatibility issues installing a mix of new and second-life batteries. Balancing the second-life batteries with the new batteries proved far more difficult than expected because an older battery is acting different compared to new batteries.

The PV system was connected to just four of the ten 10 kV/400V transformers. As the energy demand is dispersed over the ten transformers, there is a surplus of solar energy going to grid while there is still energy demand on the other transformers. When connecting a large PV system to a location with multiple transformers, a better analyses should be made of the energy demand per transformer to optimize the local use of the generated PV.

Integration of the PV, BESS, EV chargers and V2G units offers a lot of opportunities for optimisation of the electric energy system and for peak reduction and CO₂ savings. Several energy services are developed and tested at the Arena and function properly.

The 14 EV charging stations and 1 V2G unit are just the beginning. There are plans for extension to hundreds of charging stations. Several business cases have to be tested for the V2G units to find out what is optimal. Dynamic load management of the 14 EV chargers saved on installation costs. The current prices of the V2X units are very high compared to regular chargers, which may form a barrier for procurement. Several business case are possible but because of Covid-19 could not be tested during this project.

6.2. Relevant dimensions for Upscaling and Transnational transfer potential

In this paragraph we provide a brief indication of which influencing factors SEEV4-City identified for the V4ES used in this OP that play an instrumental role for both the Upscaling and Transnational transfer potential of the solutions adopted in the JC ArenaA pilot. A more in-depth analysis of the potential of individual the Dynamic Demand Management and FCR (V4)ES applied in this OP can be found in the separate 'SEEV4-City V4ES Upscaling and Transnational Transfer potential' report.

A key aspect of the JC ArenaA pilot is that it has adopted multiple (vehicle4) energy services, in effect it is a real living lab environment where several technological solutions exist together. This makes particularly interesting as it shows that locations do not have to necessarily chose between one or the other. It does of course mean additional attention needs to be paid to safeguard how different services co-exist and operate (in parallel or complementary to each other). Appointing one person or party responsible for coordinating the design, implementation and management of the system (also when solutions are adopted incrementally), is highly beneficial and recommended to capture the most potential of each individual service as well as the combined package.

We are aware that copying the combination of these services to the exact detail is not likely in terms of upscaling it to other locations, be it in The Netherlands or elsewhere. However, we identified significant overlap related to the various influencing factors, even if the impact of these may vary per solution. The extent to which these solutions can be adopted elsewhere and used at scale depends largely on influencing factors such as:

- Costs associated to installation and possible investments related to grid capacity
- Pricing structures and related legislation regarding tariffs
- Developments regarding EV adoption and availability of similar services



- Characteristics of suitable locations

In theory a large share of these semi-public charging stations are possible candidates of applying such as V2G, battery storage as back-up power, Dynamic Charging Demand Management and FCR, particularly in cases where

- larger amounts of chargers are clustered on one grid connection,
- where the grid connection upgrade / reinforcement is already a consideration,
- back-up power facilities or available space for battery storage
- (ideally) existing or space for (shared) PV or other RE is available and
- fleets with a large amount and/or share of EVs are expected to use the location

Depending on the exact local context of course, for the type of locations where such services have potential (individually or in combination) and we recommend for consideration are, amongst others: sporting and entertainment venues (such as JC Arena itself), clusters of governmental buildings, business parks (possible including locations with data centres which require a lot of back-up power), hospitals or health-care clusters, large scale residential high-rises with parking facilities. As with JC Arena, who are actively engaging parties in their vicinity to collaborate, it is worth exploring the potential with neighbouring buildings and organisations.

6.2.1. Within the country of the OP

The Netherlands is ranked at the top in terms of charging infrastructure density. Already an approximated 23,000 semi-public charging points have been installed (April 2020), with a 20-25% annual growth rate. There are a sizeable amount of sites in The Netherlands that are likely to meet such characteristics and are not limited to (semi)public sites, they can be private sites (with dedicated parking and thus requiring dedicated charging facilities) too.

Annual grid connection costs are higher for the 3x35 A grid connection compared to the regular 3x25 A for public charging stations. These tariff groups differ considerably between grid operators in the Netherlands. The price premium of the 3x35 A grid connection can mount up to €400-€700 per charging station (with 2 sockets) on an annual basis.

Currently there are fixed versus flexible tariff options, but the flexible price structuring is still limited to day/night tariffs and is determined based on the capacity of the connection, not allowing for flexibility in offering capacity availability. This long-standing regulation originally implemented to ensure equal pricing for customers is under review, as it is a significant inhibitor for accommodating for and achieving full potential the growth in EVs can give. It may be revised in coming years, but until such moment, it does limit the potential for several solutions applied here as there is little flexibility in offering compensation in the business models, which in turn impacts the financial business case and ROI.

Similarly, bi-directional charging such as V2G can result in being taxed twice. This stems from the fact that under current legislation this bi-directional exchange in electricity is seen as a product. This means that financial benefits from (allowing) the use of the (EV) battery as energy storage are less than what could be. Changing this to marking V2G bi-directional charging as a service can remove this bottleneck, but it requires a change in tax legislation.

Current investment costs for (DC) bi-directional charging units as well as for battery storage is still relatively high. There is limited market availability for such units as well EV models that are compatible for this. A stimulus to increase market availability for DC based V2G units/EV models or AC based V2G would raise the potential of this type of V4ES significantly. In terms of static battery storage, especially for the short-term, economy of scale benefits the financial business case.

Despite above mentioned bottlenecks, national legislation derived from the Renewable Energy Directive II and the Energy Performance of Buildings Directives will require many involved with (buildings with) parking facilities to think more proactively about deciding which charging solution(s) to adopt and install.



Although the electricity grid in The Netherlands is considered to be mature and has been operating steadily (with relatively little outages) for the past decades there is a significant age to the grid and with growing demand for electricity, capacity is becoming more of an issue in various regions and locations. Additionally, the demand growth is expected to rise much more because of factors such as the further digitisation of society (demand by ICT – The Netherlands, Amsterdam and Northern provinces in particular, are known as data centre hotspots) and the demand from EVs. Dutch DSOs are identifying increasing limitations to the remaining capacity for growth, as indicated by one of the Dutch DSOs in Figure 21 below. Here, yellow indicates limited capacity availability, and red means no additional capacity available. With significantly more renewable generation planned and growing demand, the grid is increasingly reaching critical mass. Grid investments are expensive but are increasingly likely to be considered financially beneficial (in the longer term), from the main grid infrastructure down to the local grid connection capacity.

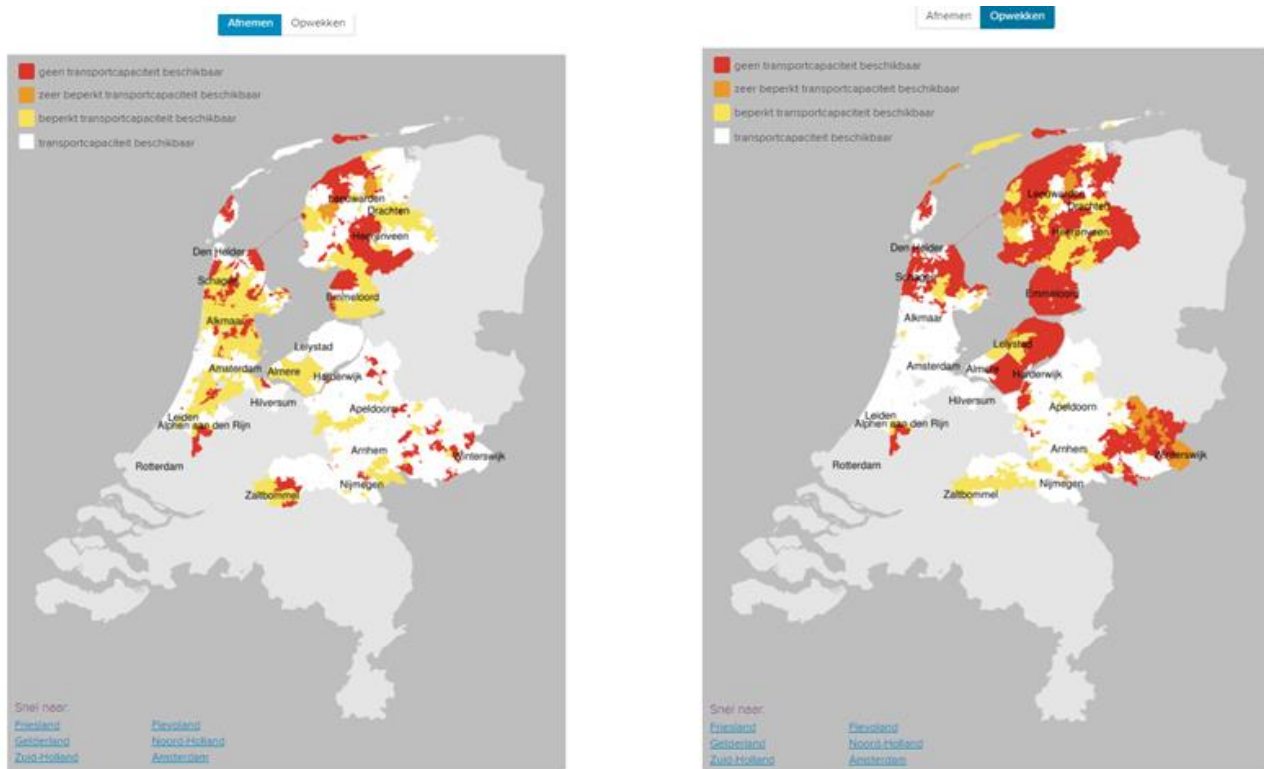

Figure 21: An overview of the Liander DSO service area indicating (remaining) capacity availability [6]

6.2.2. Transfer to other countries

As this pilot covers a number of solutions there are equally a number of similarities to what has been identified in the upscaling potential. As with The Netherlands, legislation across EU countries, including the UK, on charging infrastructure for (buildings with) parking facilities makes it crucial for city planners, as well as for (parking) facility developers and building owners to think ahead and install a charging solution that can be scaled efficiently with the fast growth of electric vehicles.

Equally, The Netherlands does not differ very much when it comes to the type of locations which meet the 'site characteristics' for possible candidates, although the geographic density may vary in largely rural areas, such as exist more so in Norway and possibly the UK than in The Netherlands and Belgium.

The uptake of EVs and charging infrastructure in UK and Norway are, as in The Netherlands, experiencing a significant growth. For Belgium the growth is still significantly lower with approximately 15,000-20,000 BEVs (i.e. battery electric vehicles in 2019) but is expected to gain momentum in coming years.

There is currently no specific V2G policy-enabling framework in place in Norway which means V2G is treated similar to PV feeding into the grid. Norway has a market-based system, which is very likely to continue. Short term aggregated storage markets could be developed within that, with new regulation that also addresses the issue of double taxation. There is a noteworthy difference for V2G compensation in the UK, where currently these are higher than averaging in the other countries and makes V2G more attractive financially, although the market availability of required hardware is similar across the board for all four countries.

6.3. Policy suggestions

At the foundation for all policy considerations lies the reality that for sectors which traditionally operated mostly as separate silos and could be similarly approached in related policies and legislation, this is no longer the case. Energy and mobility are becoming more and more entwined. The sectors themselves are moving in that direction as well and it is recommended to equally approach policies and legislation as such, both in terms of requirements and in terms of enablers.

Evaluation of energy (exchange) taxation structures

To stimulate and facilitate the energy transition and clean and sustainable mobility it would be recommended to consider new taxation structures to accommodate flexible (but transparent and fair to the customer) pricing structures and recognize new technology solutions as a different set of actors to those traditionally at play and as such require different means of taxation. This can benefit a variety of stakeholders (from EV drivers to building owners and DSOs), which in turn should stimulate uptake of these technologies and the development of innovative business models. Use pilots and existing practices to help identify the best means for energy taxation in the local context and set a path for a transition roadmap.

Ensure the legislation (i.e. Energy Taxation Directive) sets a clear tax exemption for electricity not consumed in the EV battery for transport but stored to provide grid services. This should be combined with favourable taxation of electricity consumed off-peak in order to encourage storage/consumption at off-peak times.

Introduce a new rate in legislation for a flexible connection (3 × 35 A with limitations) in countries where this is not the case, which makes this more cost competitive rather than treating it the same as household connections.

Stimulation of market

Support research collaboration and international knowledge exchange on different aspects of eV4ES and the interests of diverse stakeholders involved, such as research and education communities, original equipment manufacturers (OEM), Transmission and Distribution Systems/Networks Operators (TSO, DSO and DNO), policy makers, municipalities, service providers, EV owner/user, etc.

Energy Trading System

From a European wide perspective there is the possibility to consider inclusion of large fleets of all vehicle types under ETS but equally to allow V4ES type solutions to count towards capping (and trading) the reduction of CO₂ emissions under ETS (as such not limiting it to mere replacement of ICE trucks). This may benefit those required to comply with the cap and trade such as large fleet operators/owners making the transition to EVs and act as a stimulus for wider roll-out and adoption of varying (V4)ES solutions which in turn bring additional benefits to, for example, grid operators and CPO's.

System Approach

Apply a systems approach not only to support EVs but also smart charging and eV4ES, as well as the whole ecosystem around these.

Enhance demand-side flexibility to smartly manage the energy system which has large shares of renewables and EVs. This will reduce the overall costs, including those for grid upgrades (central and local).

Foster the value of flexible loads that allow shifting demand from peak to off-peak hours to reduce grid congestion and keep the grid stable.



References

- [1] C. o. Amsterdam, "Policy: Clean air," [Online]. Available: <https://www.amsterdam.nl/en/policy/sustainability/clean-air/>.
- [2] "Johan Crujff ArenA," [Online]. Available: <https://www.johancrujffarena.nl/international-activities/amsterdam-energy-arena.htm>.
- [3] e. a. Jorden van der Hoogt, "SEEV4-City approach to KPI Methodology," 2020.
- [4] B. Engelenburg, "Grid stabilization, peak shaving and battery backup with Vehicle-to-Grid at the Johan Crujff Arena (student report, internal document)," AUAS, 2020.
- [5] D. Roose, "Business case of a Vehicle to grid charger system in the Johan Crujff Arena (student report, internal document)," AUAS, Amsterdam, 2020.

