

# Northumbria Research Link

Citation: Camli, Berk, Kusakci, Emre, Lafci, Berkan, Salman, Seyhan, Torun, Hamdi and Yalcinkaya, Arda (2016) A Microwave Ring Resonator Based Glucose Sensor. *Procedia Engineering*, 168. pp. 465-468. ISSN 1877-7058

Published by: Elsevier

URL: <http://dx.doi.org/10.1016/j.proeng.2016.11.127> <<http://dx.doi.org/10.1016/j.proeng.2016.11.127>>

This version was downloaded from Northumbria Research Link: <http://nrl.northumbria.ac.uk/39584/>

Northumbria University has developed Northumbria Research Link (NRL) to enable users to access the University's research output. Copyright © and moral rights for items on NRL are retained by the individual author(s) and/or other copyright owners. Single copies of full items can be reproduced, displayed or performed, and given to third parties in any format or medium for personal research or study, educational, or not-for-profit purposes without prior permission or charge, provided the authors, title and full bibliographic details are given, as well as a hyperlink and/or URL to the original metadata page. The content must not be changed in any way. Full items must not be sold commercially in any format or medium without formal permission of the copyright holder. The full policy is available online: <http://nrl.northumbria.ac.uk/policies.html>

This document may differ from the final, published version of the research and has been made available online in accordance with publisher policies. To read and/or cite from the published version of the research, please visit the publisher's website (a subscription may be required.)



**Northumbria  
University**  
NEWCASTLE



**UniversityLibrary**



30th Eurosensors Conference, EUROSENSORS 2016

## A Microwave Ring Resonator Based Glucose Sensor

Berk Camli<sup>a,\*</sup>, Emre Kusakci<sup>a</sup>, Berkan Lafci<sup>b</sup>, Seyhan Salman<sup>c</sup>, Hamdi Torun<sup>a,d</sup>, Arda Yalcinkaya<sup>a,d</sup>

<sup>a</sup>Department of Electrical and Electronics Engineering, Bogazici University, Istanbul 34342, Turkey

<sup>b</sup>Department of Biomedical Engineering, Bogazici University, Istanbul 34342, Turkey

<sup>c</sup>Department of Genetics and Bioengineering, Bilgi University, Istanbul 34060, Turkey

<sup>d</sup>Center for Life Sciences and Technologies, Bogazici University, Istanbul 34342, Turkey

### Abstract

A microwave ring resonator based glucose detecting biosensor incorporating glucose oxidase enzyme is presented. Sensor uses a split ring resonator as a transducer, where the sensing operation is done by the observation of shifts in its resonant frequency. Resonator was fabricated with basic fabrication techniques and the enzyme was immobilized via conductive polymer agent PEDOT:PSS. Experimentally observed redshift of resonant frequency of the sensor in response to different loading conditions are in agreement with simulation results and theoretical expectations. Sensor selectivity is confirmed with control experiments conducted with NaCl solutions. Experiments done with different glucose solution concentrations yielded a sensor sensitivity of 0.174MHz/mgml<sup>-1</sup>.

© 2016 The Authors. Published by Elsevier Ltd. This is an open access article under the CC BY-NC-ND license

(<http://creativecommons.org/licenses/by-nc-nd/4.0/>).

Peer-review under responsibility of the organizing committee of the 30th Eurosensors Conference

*Keywords:* Metamaterials; split ring resonators; biosensors; glucose; GOx

### 1. Introduction

Biosensors became prominent tools in a wide range of fields from medical diagnostics to food safety, from process control to environmental monitoring, thanks to recent developments in research. The most significant of these are the ones dedicated to diabetes management, making up approximately 85% of the market share [1]. Similar to many other biosensor-based systems, these biosensors are generally formed of a biological sensing element exploiting the high

\* Corresponding author. Tel.: +90-212-359-7368; fax: +90-212-287-2465.

E-mail address: [berk.camli@boun.edu.tr](mailto:berk.camli@boun.edu.tr)

selectivity available in genuine biological systems and a transducer element that performs the read out. Biosensors can be classified based on the transduction mechanisms such as electrochemical, optical, acoustic, thermometric, and magnetic [2,3]. Majority of the blood glucose biosensors used extensively are electrochemical and optical ones.

In addition to the above, a simple, cost-effective, compact, and label-free biosensing technology based on ring resonators are now in a phase of development. Resonant characteristics of these electromagnetic resonators are affected by the geometry of their structure and the physical properties of the environment they are kept in. Therefore, shifts observed in their resonant frequencies can be exploited to be used in sensing [4]. Ring resonator-based biosensors were proposed in the literature for substance sensing and detection of protein-ligand interactions [4,5]. This work presents a ring resonator-based biosensor for detection of glucose incorporating glucose oxidase (GOx) enzyme as the biospecific element.

## 2. Sensor Elements

### 2.1. Transducer

Several ring resonator architectures were studied in the literature for various applications. The ring resonator structure used in this work is the basic split-ring resonator (SRR) shown in Fig. 1. It is a slit circular conducting strip implemented on a dielectric substrate. Electrical behavior of the structure can be modelled with an equivalent resistance  $R$ , capacitance  $C$ , and inductance  $L$ , forming a  $RLC$  circuit as shown in Fig. 1. The  $C$  component has two main contributions from gap capacitance  $C_{gap}$  and surface capacitance  $C_{sur}$  as shown in Equation (1).

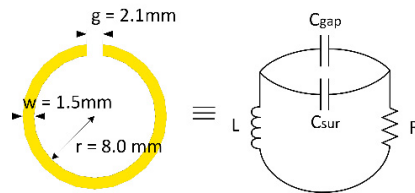

Fig. 1: SRR structure with dimensions indicated (left) with the equivalent RLC network (right).

$$C = C_{gap} + C_{sur} \quad (1)$$

Material properties aside, the  $RLC$  circuit model parameters are determined by structure geometry - defined by gap width  $g$ , inner circle radius  $r$ , conductor thickness  $t$ , and conducting strip width  $w$  (not shown in Fig. 1). The resonant frequency  $f_0$  of the resonator relates to these parameters as shown in Equation (2). Relative electrical permittivity  $\epsilon_r$ , a physical property of the medium, linearly affects  $C$  and thus is inversely related to  $f_0$ . Exploiting this relationship, the ring resonator sensor can track exposure of new materials and chemical reactions causing a change in  $\epsilon_r$  through shifts in its  $f_0$ .

$$f_0 = \frac{1}{2\pi\sqrt{LC}} \quad (2)$$

### 2.2. Biospecific Element

Since enzymes are highly specific to the molecules they react with, they are good candidates as biospecific sensing elements in biosensors. A multiple number of enzymes are used in biosensing of glucose. GOx is the enzyme most widely used in glucose biosensing due to its low cost, high bioactivity, and stability [2]. The reaction of GOx enzyme and glucose are described in the following equations:

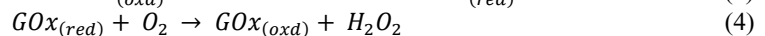
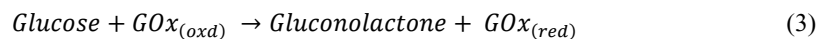

As it can be seen in the equations, GOx can rely on ambient oxygen as the electron acceptor instead of additional carriers allowing fabrication of simpler sensor systems where the oxygen provision is available. As the reaction continues substrate and product concentrations change, affecting  $\epsilon_r$  of the environment. SRR transducer can sense this change as its change of  $f_0$ . The use of GOx ensures that any substrate concentration change in the environment, or any shift in  $f_0$  of the SRR would be principally related to the presence and amount of glucose in a given sample.

### 3. Experimental Setup

A SRR was designed to have a  $f_0$  at 2GHz with dimensions indicated in Fig. 1 on a 3cm  $\times$  3cm FR4 substrate with a copper thickness  $t = 35\mu\text{m}$  using basic printed circuit board fabrication techniques. A simple masking layer made of 2.6mm thick stacked sticker layers and patterned by a Versa laser cutter so that a reservoir ditch exposes the resonator while the rest of the FR4 substrate lays covered by the mask. The enzyme was immobilized in this reservoir channel using conductive polymer PEDOT:PSS (Sigma-Aldrich 1.3wt% in water). GOx enzyme (Sigma-Aldrich, 50KU, type X-S from aspergillus niger) itself was prepared into a solution where 15mg of the product was dissolved in 25ml of 0.1M phosphate buffer of pH 6.5 containing 1.5mM ethylenediaminetetraacetic acid as antimicrobial agent and 10%w/v glycerol as stabilizer. 50 $\mu\text{l}$  of this solution was applied after a 30 $\mu\text{l}$  PEDOT:PSS solution was dried in the reservoir channel.

The resonator structure was excited with a pair of microstrip antennas and the shifts in  $f_0$  were observed by monitoring of s21 parameters using a vector network analyzer (Rohde&Schwarz ZVB4). A grounded metallic plate was added to reduce noise in the readings, while the sensor elements were kept at their positions via a 3D printed structure. Experimental setup was shown in Fig. 2.

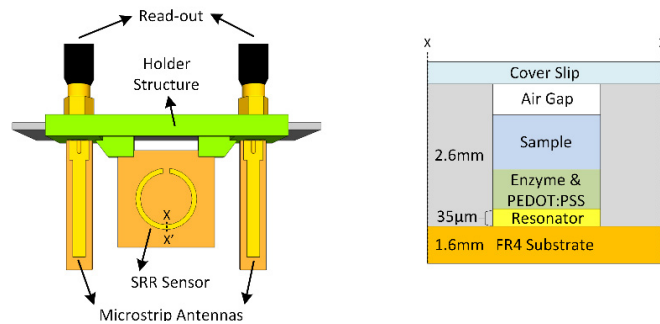

Fig. 2: Top view of basic setup elements (left) with the XX' cross section of mask/reservoir channel interface (right).

### 4. Results

CST Microwave Studio solver tool simulated s21 parameters of the bare SRR, masked SRR, and 90 $\mu\text{l}$  DI water loaded masked SRR structures. Simulated  $f_0$  values appeared at 1.97GHz, 1.84GHz, and 1.61GHz, respectively. The s21 parameters were also measured experimentally for bare SRR, masked SRR, and masked SRR loaded with different dielectrics (DI water, 0.33M glucose solution, and 1M NaCl solution of 90 $\mu\text{l}$  volumes). Plots for experimental results are given in Fig. 3(a), where simulated resonant characteristics were indicated by vertical line markers. Measured  $f_0$  values deviated from the simulated values by 0.1%, 0.5%, and 7.3% for bare SRR, masked SRR, and 90 $\mu\text{l}$  DI water loaded masked SRR cases. The overall redshift observed in measurements are in agreement with the simulation results and theoretical expectations based on the  $\epsilon_r$  values of given concentrations.

Next, NaCl and glucose solutions at same weight concentration levels were applied to the sensor system in presence of the GOx enzyme. Relative shifts of  $f_0$  were recorded within a time span of 25 minutes. The results are shown in Fig. 3(b). It was seen that the sensor responded to glucose solution 7 times more than it did to the NaCl solution. Relative shift of  $f_0$  for the glucose concentration case fits closely ( $R^2 = 0.93$ ) to a decaying exponential, following the

concentration change of a substrate in a first order chemical reaction. Such behaviour is not present for the NaCl solution, indicating a high response selectivity towards glucose solution.

Finally,  $f_0$  shift in varying glucose concentrations were investigated. Averages of five measurement results per concentration level taken 1.5 minutes into sample introduction were plotted in Fig. 3(c). As expected, higher concentration levels caused a higher shift. A line was fit to data points ( $R^2 = 0.96$ ) yielding Equation (5). Slope of the fit line indicates the sensor sensitivity, which corresponds to  $0.174\text{MHz/mgml}^{-1}$ .

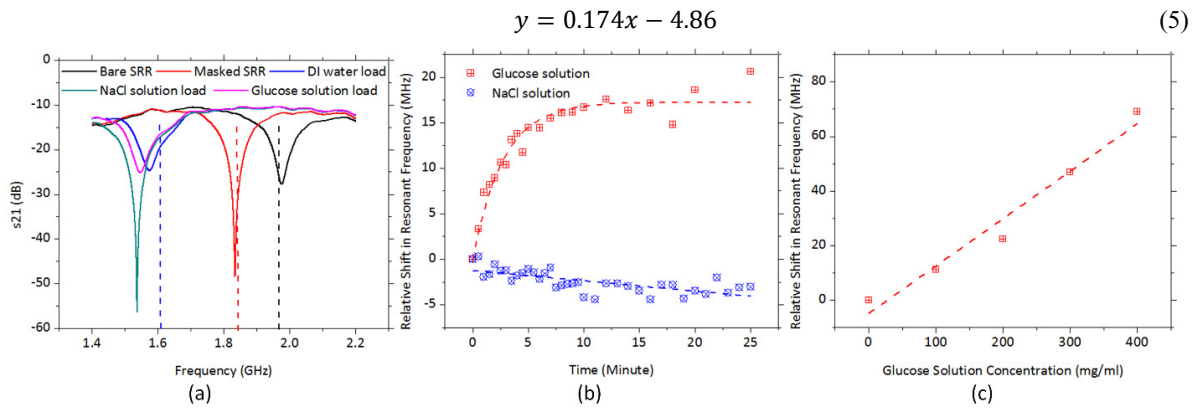

Fig. 3: Plots showing measurement results. Experimental shifts observed in  $f_0$  of the SRR under different loading conditions are shown in (a), with the dashed lines showing simulation predictions for relevant loading cases. Relative  $f_0$  shifts in response to glucose and NaCl solutions over a period of 25 minutes are plotted in (b) along with the fit lines. Averages of five measurements for relative  $f_0$  shifts vs. different glucose solution concentrations are plotted in (c).

## 5. Conclusion

In this work, we presented a SRR transducer biosensor incorporating GOx enzyme for glucose sensing. Sensing is done by tracking of the changes in  $f_0$  of the resonator due to environmental changes. Operation of basic transducing mechanism is observed both in simulation and experimental results. Simulation and experimental results were consistent with each other and theoretical expectations, resulting a highest error rate of 7.3%.

Target-specific operation of the biosensor was confirmed with the decaying exponential characteristics of  $f_0$  shift in time for a glucose solution. On the other hand, sensor response to NaCl solution was negligible as desired. Tests made with glucose solutions with different concentrations yielded a sensor sensitivity of  $0.174\text{MHz/mgml}^{-1}$  as estimated from the slope of the linear fit from the result averages.

## Acknowledgements

This work was supported by the Turkish Academy of Sciences (TUBA) and Scientific and Technological Research Council of Turkey (TUBITAK) under project code 112E250.

## References

- [1] A. P. F. Turner, Biosensors: sense and sensibility, *Chem. Soc. Rev.* 42 (2013) 3184–3196.
- [2] C. Chen, Q. Xie, D. Yang, H. Xiao, Y. Fu, Y. Tan, S. Yao, Recent advances in electrochemical glucose biosensors: a review, *RSC Adv.* 3 (2013) 4473–4491.
- [3] X. Guo, Surface plasmon resonance based biosensor technique: A review, *Journal of Biophotonics* 5 (2012) 483–501.
- [4] H. Torun, F. Cagri Top, G. Dundar, A. D. Yalcinkaya, An antenna-coupled split-ring resonator for biosensing, *Journal of Applied Physics* 116 (2014).
- [5] A. Ebrahimi, W. Withayachumankul, S. F. Al-Sarawi, D. Abbott, Microwave microfluidic sensor for determination of glucose concentration in water, in: *Microwave Symposium (MMS), 2015 IEEE 15th Mediterranean*, 2015, pp. 1–3.