

Northumbria Research Link

Citation: Deng, Xu, Wu, Haimeng, Gu, Bowen, Atkinson, Glynn, Mecrow, Barrie and Pickert, Volker (2020) Present and Future of Fault Tolerant Drives Applied to Transport Applications. In: ETG-Fb. 161: CIPS 2020, 11th International Conference on Integrated Power Electronics Systems. VDE Verlag GmbH, Berlin, pp. 608-615. ISBN 9783800752256, 9783800752263

Published by: VDE Verlag GmbH

URL: <https://www.vde-verlag.de/books/455225/etg-fb-161-...> <<https://www.vde-verlag.de/books/455225/etg-fb-161-cips-2020.html>>

This version was downloaded from Northumbria Research Link:
<http://nrl.northumbria.ac.uk/id/eprint/45276/>

Northumbria University has developed Northumbria Research Link (NRL) to enable users to access the University's research output. Copyright © and moral rights for items on NRL are retained by the individual author(s) and/or other copyright owners. Single copies of full items can be reproduced, displayed or performed, and given to third parties in any format or medium for personal research or study, educational, or not-for-profit purposes without prior permission or charge, provided the authors, title and full bibliographic details are given, as well as a hyperlink and/or URL to the original metadata page. The content must not be changed in any way. Full items must not be sold commercially in any format or medium without formal permission of the copyright holder. The full policy is available online: <http://nrl.northumbria.ac.uk/policies.html>

This document may differ from the final, published version of the research and has been made available online in accordance with publisher policies. To read and/or cite from the published version of the research, please visit the publisher's website (a subscription may be required.)



**Northumbria
University**
NEWCASTLE



University**Library**

Present and Future of Fault Tolerant Drives Applied to Transport Applications

Dr, Xu Deng^a, Dr, Haimeng Wu^a, Mr, Bowen Gu^a, Dr, Glynn Atkinson^a, Prof, Barrie Mecrow^a, Prof, Volker Pickert^a
^aElectrical Power Research Group, School of Engineering, Newcastle University, United Kingdom, NE1 7RU.

Abstract

An electric drive is an electromechanical conversion device, consisting of an electrical machine, a power electronic inverter, which interfaces between the machine and the electrical supply, a set of sensors and a digital electronic controller. Drives of this sort are manufactured in high volumes at power levels ranging from less than 1W to many MW. Reliability of the complete system depends upon the local environment, levels of thermal cycling and predictive maintenance schedules. Overall the drive system has a typical reliability of the order of 10^{-5} failures per hour, making it much more reliable than, say, an internal combustion engine.

As part of the “electrical revolution” electric drives are increasingly being developed for safety critical applications, where their reliability is several orders of magnitude below the application requirements. This is particularly the case in electrical propulsion and actuation systems in aircraft, leading to intensive research into fault tolerant electric drives. This paper will illustrate some of the most common failure mechanisms and the consequences of such failures. It will then progress to examine architectures which are fault tolerant through partitioning of the drive into several independent lanes and examine the penalties of adopting such an approach. The paper will discuss pros and cons of different fault tolerant architectures and suggests future research and development steps that are required to increase the overall safety of electric drives.

1 Introduction

The electrical revolution will see the full electrification of transport propulsion and auxiliary systems. This transformation is now well established in the automotive sector; with the hybridisation of passenger vehicles developing to plug-in hybrids and then full electric vehicles with a range exceeding 400 km. Much needs to be done to fully realise the goal, but the trajectory is clear and achievable within the regulatory deadlines; automotive traction will be fully electrified by 2050.

Electrification in the aerospace sector has been developing for over two decades with initial focus on auxiliary systems and is heading towards more flight critical systems.

Recently, the concept of hybridisation and fully electric propulsion have gained attention and significant investment [1]. Fully electrified flight already exists in demonstrator aircraft, and the target of a fully electrified  seat regional aircraft has been set for 2021 [2]. At this stage it seems that long haul aircraft will adopt a more hybrid route, and a series of architectures are emerging.

In the automotive and, even more particularly, in the aerospace sector reliability is paramount, followed by power density and system volume. Standard electrical drives do not offer the reliability, measured in failures per hour, required for flight critical systems. Likewise, high reliability in the automotive sector is necessary to gain and accelerate the public's acceptance of electric vehicles. Poor reliability can kill an automotive brand.

Electric drives have a set of common failure modes, the occurrence of which can be reduced through the use of redundancy. However, careful design is needed to ensure that redundancy does not result in excessive volume and

mass, or indeed an excessive component count which can result in an increase in failure rate.

By designing redundancy into a system, it becomes fault tolerant and capable of continued operation at a statistically lower failure rate per hour. This acceptable, and regulated, low failure rate is not possible with standard drive architectures.

2 Fault and response

A mixture of faults can always contribute to system failure, thus, the possible faults must be solved or controlled so that the system is both predictable and reliable. This can be ameliorated by regular maintenance service. Faults are usually due to the malfunction of components, such as defective devices and sensor failures, which can distort measurements or cause missed sampling. Also, broken or poor connections, weak communication, hardware or software malfunctions are the common causes of faults [3]. Developing uncontrolled faults will endanger any safety critical system and the response to them can be classified into following groups:

2.1 Benign failure

A benign failure typically has very slight impact on system performance. A relatively benign scenario of a single-switch short circuit has been discussed in a permanent magnet machine drive with a current source inverter [4]. Since one sector of its switch vector hexagon can be regulated the system phase current and the output torque will become discontinuous, but, because there is no open circuit, no significant voltage overshoot can damage other neighbouring components. Another case of benign manner has been reported in a vehicle's electrically powered traction drive, where the driver can navigate the system to a

safe position with the full use of steering, braking and other required equipment when a single module is damaged [5].

2.2 Reduced output operation

A modified H-bridge inverter-based fault-tolerant multi-level topology has been proposed to cope with switch open-circuit and short-circuit fault conditions without using any external hardware [6]. The presented fault-tolerance strategy can guarantee a continuous operation of the drive at reduced power rating and decreased DC component in the output voltage.

2.3 Maintaining full output operation

There is extremely high reliability required on aircraft primary flight control surfaces (e.g. elevator and rudder), where the system must sustain functionality under conditions such as actuator failure, power supply or command signal loss. Thus, dual actuator systems are usually used to ensure full activity in case of single or even double failure. However, such arrangements can increase the weight and cost in total. By contrast, with the help of fault-tolerant control, some systems can retain the full output without utilizing a double system. The full performance of an electrical drive system can be maintained under certain defective sensor conditions by using an easy and fast identification and isolation of faults (FDI) algorithm [3]. The average output torque power of a reluctance machine is said to be maintained effectively by employing a fault-tolerant control strategy proposed in [7].

3 Basics of fault tolerance

A fault tolerant system (FTS) can continue to function properly in the event of the failure, though possibly operating at a lower level, instead of failing completely when some parts of the system fail. Unlike a naively designed system, where complete breakdown can take place because of a small failure, the decline of operational performance in a FTS is proportional to the failure level. In some systems the ability to maintain limited functionality once parts of device fail to operate is called graceful degradation [8], which aims to prevent catastrophic failure. Unlike a replicated system, which provides multiple identical operating systems in parallel, FTS has the following features to be recognized.

3.1 Partitioning and fault isolation

Failure must be restricted to limited components or subsystems. Partitioning is a significant concept for FTS. One of the fundamental rules for design of fault-tolerant machines is to achieve electrical, magnetic, and thermal insulation between lanes. Such independent configuration of phase windings and drive circuits enables the fault to be limited to a single lane. Fault isolation is also essential to avoid certain types of fault spreading throughout the system and affecting other healthy modules. A five-phase permanent magnet brushless motor drive has been developed for an aircraft application which can generate the full rated torque even with failure of one or two phases open [9]. Other work has chosen to split the system into lanes comprised of three phases, so that the power associated with each lane can be constant.

3.2 Redundancy

Redundancy must be included in a system where the decrease of performance is not acceptable. Spare modules are normally considered for application in the event of system fault, alternatively, all modules are designed with a large margin that can operate at over-rated power when the system fails. However, such solutions for redundancy results in increased cost because more components are needed and the overall power capability of the system must be increased.

3.3 Fault detection and diagnosis

Fault detection and diagnosis are essential in fault-tolerant control (FTC) systems which are designed to maintain continued operation of the device even after failure occurs. Passive FTC systems deliver the optimum performance of the faulted drive without identifying the type of the failure. By contrast, active FTC systems use sensors or observers to diagnose a failure condition using adaptive and predictive control [10]. Numerous condition monitoring and fault diagnosis techniques for permanent magnet AC machines and drives have been reviewed in [11]. Different sources of faults and effects on PM machines have been identified and classified into magnetic, mechanical and electrical faults. Mathematical and artificial intelligence-based tools have been listed which not only focus on processing voltage, current and torque signals, but also extract inherent characteristics of data to classify faults from healthy conditions. The state-of-the-art review describing various types of induction motors faults and their diagnostic schemes has been presented in [12]. It is stated that the use of non-invasive data acquisition technologies in automated timely planning of maintenance and forecasting fault dimensions of dynamic machines will have a great scope. Advanced condition monitoring and signal processing techniques are crucial enablers for intelligent adaptive system maintenance.

3.4 Repair and recovery

In many cases a defective unit must be quickly replaced at the first opportunity following a malfunction. However, in other cases, different control strategies or topologies have been proposed to address the fault issues. To avoid use of dynamic redundancy that can increase extra volume, cost and complexity, fault tolerance and remedial strategies of the power converters for photovoltaic/fuel cell applications are presented with degraded operating modes [13]. [14] introduces a new fault-tolerant converter topology to maintain normal operation of a three-phase induction motor drive under various fault conditions.

4 Considerations in fault tolerant machine and drive topologies

Design of a fault tolerant motor drive always starts with the selection of the most appropriate type of electrical machine. The selection of the machine affects the drive topology, the power density and the intrinsic ability to be fault tolerant.

4.1 Synchronous reluctance machines

Synchronous reluctance machines benefit from their simple rotor structures. However, the mutual coupling between phases due to the overlapping windings is most likely to affect more than one phase, so grouping into multiple lanes of three phases is recommended, with additional design features introduced to minimise coupling between lanes. Using groups of isolated phases could be a solution, however, this comes with a higher cost of a much larger machine [15]. Reluctance machines have the advantage that a faulted lane will normally fail in a benign manner – there is no flux in an unexcited lane and no braking torque in the event of short-circuits, providing the lane can be isolated from the supply. This is an advantage over PM machines, though the short-term overload capability of reluctance machines is generally inferior.

4.2 Induction machines

Similar to synchronous reluctance machines, induction machines have very simple rotors, which commonly consist of rotor bars and laminations. They are relatively cheap and rugged with no brush gear when the squirrel-cage rotor form is employed. However, mutual coupling between phases and between the rotor and phases mean that fault tolerance with complete magnetic and thermal isolation is only possible when a series of separate IMs are used [16]. Recently, IMs have been used in fault tolerant applications [17, 18], where multiphase topologies have been adopted with special design minimise magnetic coupling between lanes and have very low fault current. In general, induction machines are the most difficult of all machine types to split into independent lanes, without severe compromises in performance.

4.3 Switched reluctance machines

Due to its robust rotor and simple stator structure, switched reluctance machines are natural candidates for fault tolerant applications [19]. The phases are well decoupled electrically and mechanically because of the single tooth wound coil topologies. However, there is still thermal magnetic coupling, which can be overcome by the use of a spacer tooth between phase windings and appropriate stator tooth polarity arrangements. In order to overcome low power density of switched reluctance machines, permanent magnet assists are employed for some fault tolerant aerospace applications [20]. Separate independent control of each individual phase is generally chosen, though failure of any one phase will result in large elements of torque ripple.

4.4 Permanent magnet synchronous machines

Although permanent magnet synchronous machines are considered to have the highest power density at lower power levels, there are many disadvantages compared to switched reluctance machines: the employment of magnets can make mechanical design challenging [21] and adds to the materials cost. Due to its electromagnetic characteristics, the excitation field will drive current in armature windings in an event of either an inverter fault or winding

fault. In the worst case, a short-circuit fault appears, it can lead to additional damage, including excessive heating of the motor windings.

In the past few decades, a lot of research on mechanical and thermal optimization for permanent magnet synchronous machines has been undertaken to overcome these problems [22]. A high per unit reactance design is validated as an effective method, which can limit the value of the fault current in shorted armature turns by the remedial application of a winding terminal short-circuit by the drive. A terminal short-circuit will produce drag torque, which must be overcome by the remaining healthy phases. A well-designed permanent magnet synchronous machine is considered to be the most power dense and most efficient machine topology, a definite attraction for most transport applications.

4.5 Considerations for the electric drive

The main considerations of fault-tolerant electric drives are listed as below,

- a) The converter topologies and the control units should support lane isolation;
- b) The control units should have a fast and reliable fault detection and diagnosis capability;
- c) Under certain fault conditions, drive functionality/availability must be maintained.

In terms of the converter topology, a set of isolated H bridges, each supplying a single isolated winding [23], or a multiple set of three phase drives supplying multiple isolated sets of three phase windings [24] have been widely used as they both supply excellent lane isolation. Independent control units and drive circuits are essential. Each power module of an isolated bridge will have an independent gate drive circuit and assisted power supply, meanwhile, each sub-machine will have an isolated control unit.

There are three main sources of faults in a drive system, namely, mechanical, electrical, and sensor faults [25]. The fault detection and diagnosis algorithms are embedded in the control unit [26, 27], therefore, the drive can rapidly detect a power device or motor winding fault and act accordingly to maintain the functionality.

5 Recent fault tolerant dc/dc converter topologies

In transport application the power grid architecture varies with the type of vessel, the required drive power, the type of main energy source and the number of electric loads that need to be powered. The simplest architecture is the connection of an electric drive to a battery. More complex architectures include a full dc-grid with many connected sinks and sources. Regardless of the architecture, if the inverter voltage does not match with the battery voltage or does not match with the dc-grid voltage a dc/dc converter becomes essential. Other reasons to install a dc/dc converter is isolation. Therefore, a dc/dc converter becomes an integral part of an electric drive and as such must fulfil fault tolerant design.

Like in most power electronics systems any switched mode dc/dc converter is made from semiconductor switches, capacitors, inductors and if required transformers. It is widely known that semiconductor switches cause most of the failures. There is no clear prediction on how a solder-based power semiconductor device fails. It either can go open-circuit or short-circuit. This makes fault tolerant design more challenging as any fault tolerant design must cope with both outcomes.

In the previous chapter it was stated that a set of isolated H-bridge inverters is used in fault tolerant drives. This requires that each H-bridge inverter must be powered individually. Therefore, to operate one fault tolerant drive 2 to 3 power lanes are required each supplying one inverter. Consequently, each lane requires its own dc/dc converter that is connected between the lane supply and the lane inverter. Like connecting electric drives in parallel as a measure of redundancy to increase availability, dc/dc converters can also be connected in parallel. This configuration is actually more common with dc/dc converters than with electric drives. A common application for using parallel connected dc/dc converters is data storage centres. Figure 1 shows the principle of redundancy.

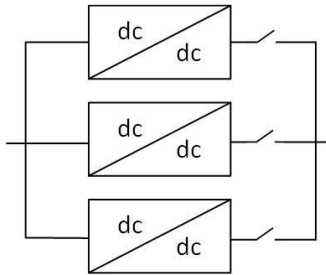

Figure 1. Redundancy for dc/dc converter

Figure 1 shows that each of the dc/dc converter can either fully operate or share the power flow equally (power sharing) or one or several converters are not activated and come only into action when one or several others have failed (stand-by mode). In principal, redundancy is independent from the dc/dc converter topology and as such any known dc/dc converter circuit is suitable. However, redundancy is known to increase cost as it does increase the number of active and passive components, number of microprocessors, cooling and connectors.

An example of a redundant dc/dc converter circuit is shown in Figure 2.

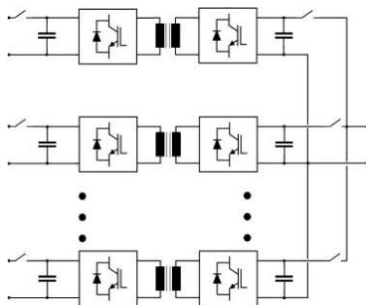

Figure 2. Dual-Active-Bridge (DAB) as an example for a redundant dc/dc converter system

In some application it is essential that power in an electric drive must flow in both directions to deal with motoring

mode and regeneration mode. Therefore, the dc/dc converter must show bi-directional power flow. The literature has presented many bi-directional converters [28] and the Dual-Active-Bridge (DAB) converter is one of the most researched converter topologies. The reason for its popularity is circuit simplicity due to its mirrored circuit structure. Effectively the DAB is a back-to-back full bridge inverter topology that is connected via a transformer. This simplicity allows a compact structure. In addition, wide-bandgap devices can be used to reduce the transformer size dramatically and therefore the DAB can be built to high power density. Furthermore, the DAB is able operating in resonance to achieve high efficiency. Finally, control of a DAB is relatively simple. Due to its popularity there are many publications on DAB [29].

The transformer in the DAB allows isolation between the input cell and the output cell. Thus, a failure in one of the cells does not travel through easily, which in fault tolerant systems is essential. The circuit shown in Figure 2, can be operated in power sharing mode or as stand-by mode. A variation of the circuit was presented in [30], where previously the individual DAB transformers are replaced with one multi-tapped transformer as shown in Figure 3. In this approach all DABs share the power. The benefit of circuit [30] is that in case one cell fails (either the input or the output cell) the remaining cell can still operate. However, as mentioned already redundancy is not a cost-effective solution.

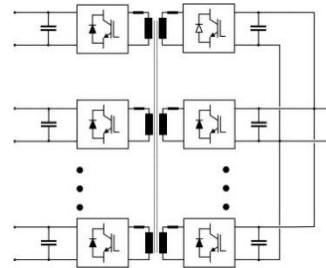

Figure 3. Dual-Active-Bridge (DAB) with multi-windings transformer

Fault tolerant design is possible without using redundancy and many fault tolerant dc/dc converters have been proposed [31-33]. Like in fault tolerant inverter designs, fuses in series with semiconductor switches to isolate short-circuit switches from the circuit and inclusion of redundant legs that are activated by switching them into the circuit are also common in fault tolerant dc/dc converter design. An example is shown in Figure 4 [34].

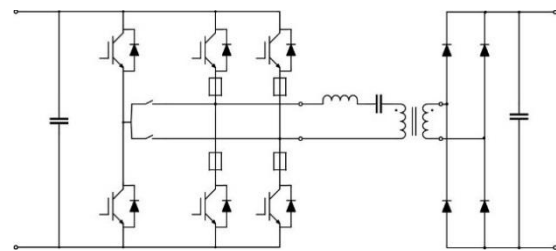

Figure 4. Example of a Full Bridge Fault Tolerant dc/dc converter using an additional switching leg and fuses
The extra leg in Figure 4 is activated, once it is known that one of semiconductor switches has failed (short-circuit). The switch shown in Figure 4 can be realised with a

TRIAC for example. To isolate the failed semiconductor from the circuit the in series connected fuse must be blown. This can be done by turning on the remaining healthy semiconductor switch in that leg to produce a short-circuit current. However, with this approach there is the risk that the second fuse also blows. To avoid this risk Thyristors are added to the upper and lower rail who once activated will produce the short-circuit current so that only one fuse blows.

An alternative to Figure 4 is described in [35]. Here an additional leg is not required as Full Bridge operation will change to Half-Bridge operation. This change allows that the faulty leg is ignored but power is still delivered. Operating at Half-Bridge mode results in reducing the output voltage to half. For this reason, the rectifier circuit must be reconfigured to stabilise the output voltage [35].

All of the circuits shown above are using single-phase transformers which have the risk of a single-point failure. Three-phase DABs and three-phase Full-Bridge converters using multi-tapped transformers can overcome this problem [36], however complexity and cost increases substantially.

Other popular bi-directional dc/dc converter topologies are the buck, the boost, the four-switch, the inverting buck-boost, Cuk and Sepic [28] (Figure 5).

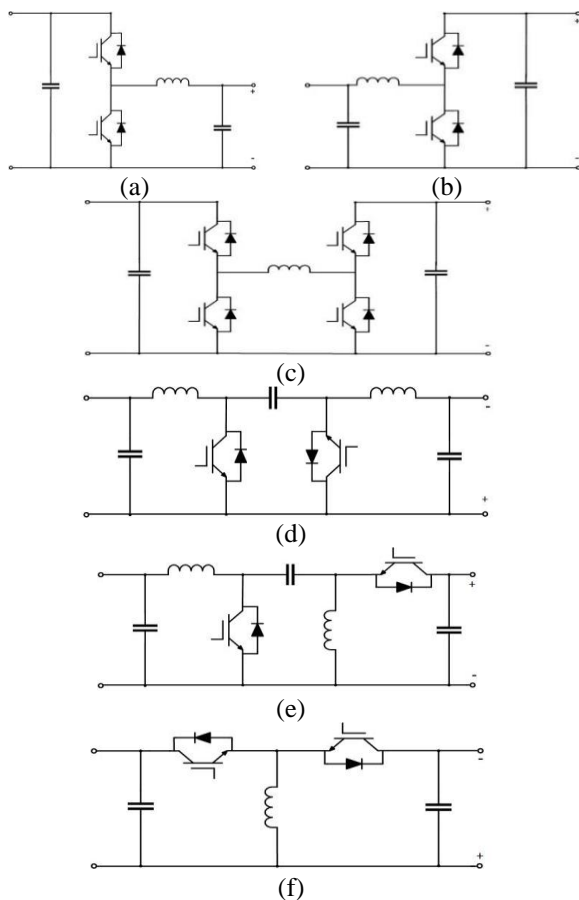

Figure 5. Bi-directional non-isolated dc/dc converter topologies: a) Buck, b) Boost, c) four-switch, d) Cuk, e) Sepic, f) inverting buck/boost.

For most of the converters shown in Figure 5 attempts have been made to apply a fault tolerant design. For example, in

[37] buck/boost circuits have been connected in series to allow fault tolerant operation. In [38] a two-stage fault-tolerant buck/boost converter was proposed allowing to connect three sinks/sources. However, most of the presented work focused either on faults during buck mode or during boost mode but not both. Reference [39] describes a fault tolerant transformer-based isolated Cuk converter raising again the issue of a single-point failure.

There are dc/dc converters which do not require any additional significant number of components in order to deal with faults due to their nature of operation: interleaved dc/dc converters [40, 41] and modular multilevel dc/dc converters [42, 43]. The interleaved dc/dc converter operates on the base of phase shifting between the branches. As such gating to the healthy switches will be adjusted after a faulty switch has been identified without disturbing the required symmetry needed in an interleaved dc/dc converter. Modular multilevel converters also do not require significant additional components to achieve fault tolerant operation. That is because these types of converters have enough redundant switches in the original structure for bypassing a faulty switch. Once a switch has been identified as a faulty switch the control strategy is reconfigured. Examples of an interleaved and modular multilevel dc/dc converters are shown in Figure 6.

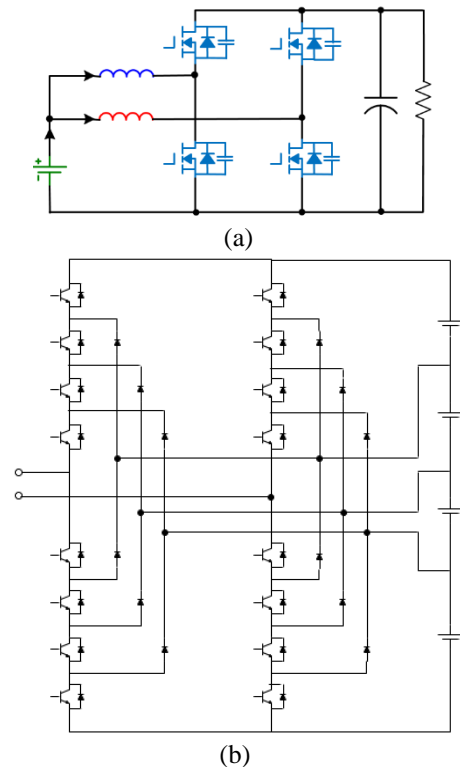

Figure 6: (a) example of an interleaved converter, (b) example of a modular multilevel dc/dc converter.

There is a much greater number of dc/dc converter topologies compared to the number of electric drives topologies and for part of the wide range of DC-DC converter topologies, there are many fault tolerant solutions available in literature and there is no one-fit-for-all solution. What is missing in the literature are holistic approaches for fault tolerant electric drives with front-end dc/dc converters. So

far, each system (dc/dc converter and electric drive) has been looked at on an individual level to achieve fault tolerant solutions. Considering that electric drives with integrated dc/dc converters have lots to offer such as efficiency gains, high power density and improvement in EMI, more research must be conducted for holistic fault tolerant solutions for electric drives with integrated dc/dc converters.

6 Recent fault tolerant drive applications

6.1 Aerospace applications

Most of the early work on fault tolerant drives was driven by the desire to move to the “more electric” aircraft. Twenty years later this remains the main driver. Fault tolerance has been considered for main engine fuel pumps, wing actuation systems, nose-wheel steering and electric taxiing, amongst others [44, 45]. The primary objectives have been to increase system reliability above 10^5 hours between failures. The broader concepts have also been used by the industry in the development of large aerospace generators.

A standard drive may typically have $10^4 - 10^5$ hours between failures, though there is a large variation, depending upon the working environment. Fault tolerance may be able to extend this by orders of magnitude, but there is still no strong belief that it can be extended to 10^9 hours, which is needed for flight critical applications, where a failure could result in catastrophic loss of the aircraft. There is a strong need for more work in the following areas:

- a) Greater information on the reliability of materials and components of drive systems, so that there is much better knowledge of the causes of failure.
- b) Use of the information from above to increase the intrinsic reliability of systems, through better materials and manufacturing methods.
- c) Improvements to the thermal management of systems to reduce the thermal stressing which occurs during operation.
- d) More active failure prediction monitoring, leading to better programmes of replacement and maintenance.

The advent of hybrid electric propulsion and full electric aircraft is giving new impetus for work. Full electric propulsion may result in MW range motors, driving propulsion fans and, in the case of hybrid propulsion, there will be generators coupled directly to the fan engines, creating a multi power system in the aircraft. It is inevitable that these systems will have stringent reliability requirements, necessitating multiple power busses in the aircraft, incorporating fault tolerance and redundancy.

6.2 Other sectors

Ship propulsion is becoming increasingly hybrid electric in nature with podded propulsion motor drives, or drives sited within the main hull of the vessel. For naval warships there has been continued requirements to operate following a failure, leading to the development of “multi-phase” induction motors, comprised of 9, or even 15, phases. There has

been extensive work on how to continue operation in the event of any one phase module being lost via an open-circuit fault. Through rearrangement of the angle between the remaining phase currents it is possible to compensate for the missing phase [46-49].

There has been a much smaller body of work seeking to continue operation of an induction motor with a short-circuit failure of one phase. This is a much more challenging scenario, which has so far only been tackled with limited success.

Growth in the electric vehicle sector is huge, but considerations of fault tolerance are still in the early stages of development. As regulations become stricter this is likely to change, even if it is only to provide “limp home” operation following a fault. There are increasing numbers of concepts which involve the use of more than one traction motor and it is important to ensure that any one failure is benign in nature. Reference [50] is a particularly good example which is looking at fault tolerance of in-wheel motor drives. In this work the wheel is powered by two or four motors. Particular care was taken to ensure that a failure in any one wheel does not lead to uncontrolled operation of the vehicle [50]. This is achieved through careful design, with the additional measure of splitting each wheel motor into several sub-motors, each controlled by a separate inverter.

7 Literature

- [1] airbus.com, "E-Fan X A giant leap towards zero-emission flight," <https://www.airbus.com/innovation/future-technology/electric-flight/e-fan-x.html>.
- [2] rolls-royce.com, "The world's most powerful flying generator," <https://www.rolls-royce.com/media/our-stories/discover/2019/e-fan-x-continues-to-explore.aspx>
- [3] H. Berriri, M. W. Naouar, and I. Slama-Belkhdja, "Easy and fast sensor fault detection and isolation algorithm for electrical drives," *IEEE transactions on power electronics*, vol. 27, pp. 490-499, 2011.
- [4] Y. Zhang, W. Zhang, and T. Jahns, "Investigation of single-switch short-circuit fault characteristics of a PM machine drive with a current source inverter," in *2015 IEEE International Electric Machines & Drives Conference (IEMDC)*, 2015, pp. 967-973.
- [5] P. Mellor, T. Allen, R. Ong, and Z. Rahma, "Faulted behaviour of permanent magnet electric vehicle traction drives," in *IEEE International Electric Machines and Drives Conference, 2003. IEMDC'03.*, 2003, pp. 554-558.
- [6] K. N. Reddy and S. Pradabane, "Modified H-bridge inverter based fault-tolerant multilevel topology for open-end winding induction motor drive," *IET Power Electronics*, vol. 12, pp. 2810-2820, 2019.
- [7] D. Hu, B. Zhou, Z. Gan, X. Huang, and X. Zhou, "Research of fault-tolerant strategy for power converter of four-phase DSEM drive," in *2016 19th International Conference on Electrical Machines and Systems (ICEMS)*, 2016, pp. 1-5.
- [8] H. Mekki, O. Benzineb, D. Boukhetala, L. Chrifi-Alaoui, and M. Tadjine, "Fault tolerant design for

- permanent magnet synchronous motor using fuzzy speed controller," *IFAC-PapersOnLine*, vol. 49, pp. 315-320, 2016.
- [9] M. Villani, M. Tursini, G. Fabri, and L. Castellini, "High reliability permanent magnet brushless motor drive for aircraft application," *IEEE transactions on industrial electronics*, vol. 59, pp. 2073-2081, 2011.
- [10] K. Klimkowski and M. Dybkowski, "Adaptive fault tolerant direct torque control structure of the induction motor drive," in *2015 International Conference on Electrical Drives and Power Electronics (EDPE)*, 2015, pp. 7-12.
- [11] S. Choi, M. S. Haque, M. T. B. Tarek, V. Mulpuri, Y. Duan, S. Das, *et al.*, "Fault diagnosis techniques for permanent magnet AC machine and drives—A review of current state of the art," *IEEE Transactions on Transportation Electrification*, vol. 4, pp. 444-463, 2018.
- [12] A. Choudhary, D. Goyal, S. L. Shimi, and A. Akula, "Condition monitoring and fault diagnosis of induction motors: A review," *Archives of Computational Methods in Engineering*, vol. 26, pp. 1221-1238, 2019.
- [13] D. Guilbert, A. Gaillard, A. N'Diaye, and A. Djerdir, "Power switch failures tolerance and remedial strategies of a 4-leg floating interleaved DC/DC boost converter for photovoltaic/fuel cell applications," *Renewable Energy*, vol. 90, pp. 14-27, 2016.
- [14] B. S. S. G. Yelamarthy and S. R. Sandepudi, "A Novel Fault-Tolerant Converter Topology for Induction Motor Drive," in *2018 IEEE International Conference on Power Electronics, Drives and Energy Systems (PEDES)*, 2018, pp. 1-6.
- [15] S. Taghavi and P. Pillay, "A Sizing Methodology of the Synchronous Reluctance Motor for Traction Applications," *IEEE Journal of Emerging and Selected Topics in Power Electronics*, vol. 2, pp. 329-340, 2014.
- [16] M. Popescu, D. G. Dorrell, L. Alberti, N. Bianchi, D. A. Staton, and D. Hawkins, "Thermal Analysis of Duplex Three-Phase Induction Motor Under Fault Operating Conditions," *IEEE Transactions on Industry Applications*, vol. 49, pp. 1523-1530, 2013.
- [17] E. Levi, "Multiphase Electric Machines for Variable-Speed Applications," *IEEE Transactions on Industrial Electronics*, vol. 55, pp. 1893-1909, 2008.
- [18] L. Alberti and N. Bianchi, "Experimental Tests of Dual Three-Phase Induction Motor Under Faulty Operating Condition," *IEEE Transactions on Industrial Electronics*, vol. 59, pp. 2041-2048, 2012.
- [19] W. Ding, Y. Hu, and L. Wu, "Investigation and Experimental Test of Fault-Tolerant Operation of a Mutually Coupled Dual Three-Phase SRM Drive Under Faulty Conditions," *IEEE Transactions on Power Electronics*, vol. 30, pp. 6857-6872, 2015.
- [20] S. Ullah, S. P. McDonald, R. Martin, M. Benarous, and G. J. Atkinson, "A Permanent Magnet Assist, Segmented Rotor, Switched Reluctance Drive for Fault Tolerant Aerospace Applications," *IEEE Transactions on Industry Applications*, vol. 55, pp. 298-305, 2019.
- [21] Y. Wang, J. Ma, C. Liu, G. Lei, Y. Guo, and J. Zhu, "Reduction of Magnet Eddy Current Loss in PMSM by Using Partial Magnet Segment Method," *IEEE Transactions on Magnetics*, vol. 55, pp. 1-5, 2019.
- [22] W. Tong, R. Sun, C. Zhang, S. Wu, and R. Tang, "Loss and Thermal Analysis of a High-Speed Surface-Mounted PMSM With Amorphous Metal Stator Core and Titanium Alloy Rotor Sleeve," *IEEE Transactions on Magnetics*, vol. 55, pp. 1-4, 2019.
- [23] L. d. Lillo, L. Empringham, P. W. Wheeler, S. Khwan-On, C. Gerada, M. N. Othman, *et al.*, "Multiphase Power Converter Drive for Fault-Tolerant Machine Development in Aerospace Applications," *IEEE Transactions on Industrial Electronics*, vol. 57, pp. 575-583, 2010.
- [24] B. Wang, J. Wang, A. Griffio, and B. Sen, "Stator Turn Fault Detection by Second Harmonic in Instantaneous Power for a Triple-Redundant Fault-Tolerant PM Drive," *IEEE Transactions on Industrial Electronics*, vol. 65, pp. 7279-7289, 2018.
- [25] A. Bellini, F. Filippetti, C. Tassoni, and G. Capolino, "Advances in Diagnostic Techniques for Induction Machines," *IEEE Transactions on Industrial Electronics*, vol. 55, pp. 4109-4126, 2008.
- [26] X. Wang, Z. Wang, Z. Xu, M. Cheng, W. Wang, and Y. Hu, "Comprehensive Diagnosis and Tolerance Strategies for Electrical Faults and Sensor Faults in Dual Three-Phase PMSM Drives," *IEEE Transactions on Power Electronics*, vol. 34, pp. 6669-6684, 2019.
- [27] W. Wang, J. Zhang, M. Cheng, and S. Li, "Fault-Tolerant Control of Dual Three-Phase Permanent-Magnet Synchronous Machine Drives Under Open-Phase Faults," *IEEE Transactions on Power Electronics*, vol. 32, pp. 2052-2063, 2017.
- [28] R. Khanaki, G. R. Walker, M. A. H. Broadmeadow, and G. F. Ledwich, "Integration of non-isolated DC-DC converters in battery storage systems – a topological exploration," *The Journal of Engineering*, vol. 2019, pp. 4185-4189, 2019.
- [29] B. Zhao, Q. Song, W. Liu, and Y. Sun, "Overview of Dual-Active-Bridge Isolated Bidirectional DC-DC Converter for High-Frequency-Link Power-Conversion System," *IEEE Transactions on Power Electronics*, vol. 29, pp. 4091-4106, 2014.
- [30] G. B. M. Liserre, L. Costa, M. Andresen, Spannungswandler, Verfahren zu dessen Betrieb und Computerprogramm, "German Patent DE102017104138," 2017.
- [31] M. Gleissner and M. Bakran, "Reliable & Fault-Tolerant DC/DC-Converter Structures," in *PCIM Europe 2014; International Exhibition and Conference for Power Electronics, Intelligent Motion, Renewable Energy and Energy Management*, 2014, pp. 1-8.
- [32] D. Guilbert, A. Gaillard, A. N. Diaye, and A. Djerdir, "Energy efficiency and fault tolerance comparison of DC/DC converters topologies for fuel cell electric vehicles," in *2013 IEEE Transportation Electrification Conference and Expo (ITEC)*, 2013, pp. 1-7.

- [33] K. A. Ambusaidi, V. Pickert, and B. Zahawi, "Computer Aided Analysis of Fault Tolerant Multilevel DC/DC Converters," in *2006 International Conference on Power Electronic, Drives and Energy Systems*, 2006, pp. 1-6.
- [34] W. Zhang, D. Xu, P. N. Enjeti, H. Li, J. T. Hawke, and H. S. Krishnamoorthy, "Survey on Fault-Tolerant Techniques for Power Electronic Converters," *IEEE Transactions on Power Electronics*, vol. 29, pp. 6319-6331, 2014.
- [35] L. Costa, G. Buticchi, and M. Liserre, "A Fault-Tolerant Series-Resonant DC-DC Converter," *IEEE Transactions on Power Electronics*, vol. 32, pp. 900-905, 2017.
- [36] S. Baek and S. Bhattacharya, "Isolation Transformer for 3-Port 3-Phase Dual-Active Bridge Converters in Medium Voltage Level," *IEEE Access*, vol. 7, pp. 19678-19687, 2019.
- [37] L. Yu, D. Ye, and C. Moo, "Discharging scenario of serial buck-boost battery power modules with fault tolerance," in *IECON 2015 - 41st Annual Conference of the IEEE Industrial Electronics Society*, 2015, pp. 001622-001626.
- [38] S. Siouane, S. Jovanović, and P. Poure, "Open-Switch Fault-Tolerant Operation of a Two-Stage Buck/Buck-Boost Converter With Redundant Synchronous Switch for PV Systems," *IEEE Transactions on Industrial Electronics*, vol. 66, pp. 3938-3947, 2019.
- [39] A. A. Sayyid and M. N. Gitau, "High-power fault-tolerant and multiple independent loads LED driver," in *IECON 2014 - 40th Annual Conference of the IEEE Industrial Electronics Society*, 2014, pp. 3010-3016.
- [40] H. Wu, V. Pickert, D. Giaouris, and B. Ji, "Nonlinear Analysis and Control of Interleaved Boost Converter Using Real-Time Cycle to Cycle Variable Slope Compensation," *IEEE Transactions on Power Electronics*, vol. 32, pp. 7256-7270, 2017.
- [41] P. James, Forsyth, A, Calderon-Lopez, G & Pickert, V, "DC-DC converter for hybrid and all electric vehicles," *24th International Battery, Hybrid and Fuel Cell Electric Vehicle Symposium and Exhibition*, vol. 2, pp. 1462-1470, 2009.
- [42] K. Ambusaidi, V. Pickert, and B. Zahawi, "New Circuit Topology for Fault Tolerant H-Bridge DC-DC Converter," *IEEE Transactions on Power Electronics*, vol. 25, pp. 1509-1516, 2010.
- [43] F. H. Khan and L. M. Tolbert, "Bi-directional power management and fault tolerant feature in a 5-kW multilevel dc-dc converter with modular architecture," *IET Power Electronics*, vol. 2, pp. 595-604, 2009.
- [44] X. Huang, A. Goodman, C. Gerada, Y. Fang, and Q. Lu, "Design of a Five-Phase Brushless DC Motor for a Safety Critical Aerospace Application," *IEEE Transactions on Industrial Electronics*, vol. 59, pp. 3532-3541, 2012.
- [45] J. W. Bennett, B. C. Mecrow, D. J. Atkinson, C. Maxwell, and M. Benarous, "Fault-tolerant electric drive for an aircraft nose wheel steering actuator," *IET Electrical Systems in Transportation*, vol. 1, pp. 117-125, 2011.
- [46] O. D. Momoh, "Performance evaluation of delta connected 9-phase induction machine for electric propulsion application," in *2015 IEEE Electric Ship Technologies Symposium (ESTS)*, 2015, pp. 224-229.
- [47] M. J. Duran and F. Barrero, "Recent Advances in the Design, Modeling, and Control of Multiphase Machines—Part II," *IEEE Transactions on Industrial Electronics*, vol. 63, pp. 459-468, 2016.
- [48] E. Levi, R. Bojoi, F. Profumo, H. A. Toliyat, and S. Williamson, "Multiphase induction motor drives - a technology status review," *IET Electric Power Applications*, vol. 1, pp. 489-516, 2007.
- [49] Z. Liu, J. Wu, and L. Hao, "Coordinated and fault-tolerant control of tandem 15-phase induction motors in ship propulsion system," *IET Electric Power Applications*, vol. 12, pp. 91-97, 2018.
- [50] C. J. Ifedi, B. C. Mecrow, S. T. M. Brockway, G. S. Boast, G. J. Atkinson, and D. Kostic-Perovic, "Fault-Tolerant In-Wheel Motor Topologies for High-Performance Electric Vehicles," *IEEE Transactions on Industry Applications*, vol. 49, pp. 1249-1257, 2013.