

# Northumbria Research Link

Citation: Ganjian, Tayebah, Baghersalimi, Gholamreza and Ghassemlooy, Zabih (2020) Performance Evaluation of a MIMO VLC System Employing Single Carrier Modulation with Frequency Domain Equalization. In: 2020 3rd West Asian Symposium on Optical and Millimeter-wave Wireless Communication (WASOWC). Institute of Electrical and Electronics Engineers Inc., Piscataway, NJ, pp. 1-5. ISBN 9781728186924, 9781728186917

Published by: Institute of Electrical and Electronics Engineers Inc.

URL: <https://doi.org/10.1109/WASOWC49739.2020.9410001>  
<<https://doi.org/10.1109/WASOWC49739.2020.9410001>>

This version was downloaded from Northumbria Research Link:  
<http://nrl.northumbria.ac.uk/id/eprint/46409/>

Northumbria University has developed Northumbria Research Link (NRL) to enable users to access the University's research output. Copyright © and moral rights for items on NRL are retained by the individual author(s) and/or other copyright owners. Single copies of full items can be reproduced, displayed or performed, and given to third parties in any format or medium for personal research or study, educational, or not-for-profit purposes without prior permission or charge, provided the authors, title and full bibliographic details are given, as well as a hyperlink and/or URL to the original metadata page. The content must not be changed in any way. Full items must not be sold commercially in any format or medium without formal permission of the copyright holder. The full policy is available online: <http://nrl.northumbria.ac.uk/policies.html>

This document may differ from the final, published version of the research and has been made available online in accordance with publisher policies. To read and/or cite from the published version of the research, please visit the publisher's website (a subscription may be required.)

# *Performance Evaluation of a MIMO VLC System Employing Single Carrier Modulation with Frequency Domain Equalization*

Tayebeh Ganjian

*Department of Electrical Engineering  
University of Guilan,  
Rasht, Iran, 4199613776  
tganjian@msc.guilan.ac.ir*

Gholamreza Baghersalimi,

*Department of Electrical Engineering,  
University of Guilan,  
Rasht, Iran, 4199613776  
bsalimi@guilan.ac.ir*

Zabih Ghassemlooy

*Optical Communications Research  
Group, Faculty of Engineering and  
Environment, Northumbria  
University  
Newcastle upon Tyne, UK, NE1 8ST  
z.ghassemlooy@northumbria.ac.uk*

**Abstract**— In this paper, a multiple input – multiple output (MIMO) visible light communications utilizing single-carrier modulation combined with frequency domain equalization is investigated. We study the repetition coding (RC) and spatial multiplexing (SMP) schemes and show that MIMO with RC offers improved performance compared with single input – single output system, however MIMO with SMP increases the spectral efficiency at the cost of bit error rate degradation.

**Keywords**— MIMO, VLC, Equalization, SCFDE, OOK.

## I. INTRODUCTION

Light emitting diodes (LEDs) are designed based on solid-state lighting, and compared with the traditional incandescent and fluorescent lamps offer many benefits including longer life-span, higher energy efficiency, lower power consumption and faster switching capability, therefore it is predicted that they will replace the traditional lamps [1]. The latter feature of LED makes it highly suitable for data communications. In recent years, with the development of solid-state-based LEDs, there has been a growing interest in optical wireless communication (OWC), which utilizes the optical spectrum for data communications and indoor positioning [1-3]. Today, with the popularity and widespread use of smartphones, we are experiencing a rapid growth in wireless data traffic, which leads to a serious congestion in the radio frequency (RF) spectrum. Employing visible light communications (VLC), as a specific type of the OWC technology, in certain applications releases a considerable portion of the RF spectrum for usage in areas where most needed such as outdoor environment. Compared with the traditional and most widely adopted RF wireless technologies, VLC has many advantages such as the potential of offering high data rates using the license-free spectrum, security, and free from RF interference.

In VLC links there are two possible transmission modes of line of sight (LOS) and non-line of sight (NLOS). In LOS propagation, the light beam experiences channel losses but minimum amount of dispersion, which can be considered small in indoor environment, thus offering much higher transmission data rates. However, in NLOS links, the reflected light beams will experience higher delay spread (i.e., higher dispersion) and therefore reduced transmission

data rates due to intersymbol interference (ISI) compared with the LOS [1]. One solution to increase the transmission data rate in VLC systems is to use multicarrier modulation schemes such as orthogonal frequency division multiplexing (OFDM) [4]. Note, however, in intensity modulation-based VLC systems, the data signal must be non-negative and real, thus DC-biasing is needed. Different OFDM schemes have been proposed and fully investigated including asymmetrically clipped optical (ACO-) OFDM and DC-biased OFDM [1, 4-5]. Nonetheless, the OFDM-based VLC, where different subcarriers are summed up, suffers from a high peak-to-average power ratio (PAPR) due to the limited linearity and dynamic range of the LED power-current characteristic [1, 3-9].

Single carrier frequency domain equalization (SCFDE) schemes have been proposed as an alternative to OFDM. In [10] it was shown that SCFDE can perform the same as OFDM. In addition, since it uses only a single carrier, the system does not suffer from PAPR. In [11], a VLC SCFDE system was evaluated using on and off keying (OOK) data format in an indoor scenario and it was shown that SCFDE with a lower complexity offered improved performance compared with OFDM. In [12], a SCFDE VLC system was investigated based on pulse amplitude modulation (PAM) and it was concluded that PAM-SCFDE generally outperforms different OFDM schemes by considering several metrics such as BER, spectral efficiency, system complexity, and PAPR.

Indoor VLC is based on utilizing LED arrays, which are already installed for illumination. The transmitter's (Tx's) arrangement on the ceiling affects the channel characteristics and thus the system performance. In [13, 14], the impact of Tx's position in VLC systems are studied by simulation. In [13] a VLC system is simulated and the received power is investigated by considering different Tx positions. In [14] it is shown that in a multiple-input single-output (MISO) VLC system, Tx arrangement affects system performance and the received power.

In order to provide illumination, generally in a typical room, multiple LED arrays are used, which can be readily used as multiple-input multiple-output (MIMO). The MIMO technique provides high spectral efficiency and therefore increased data rates, which has been used in RF

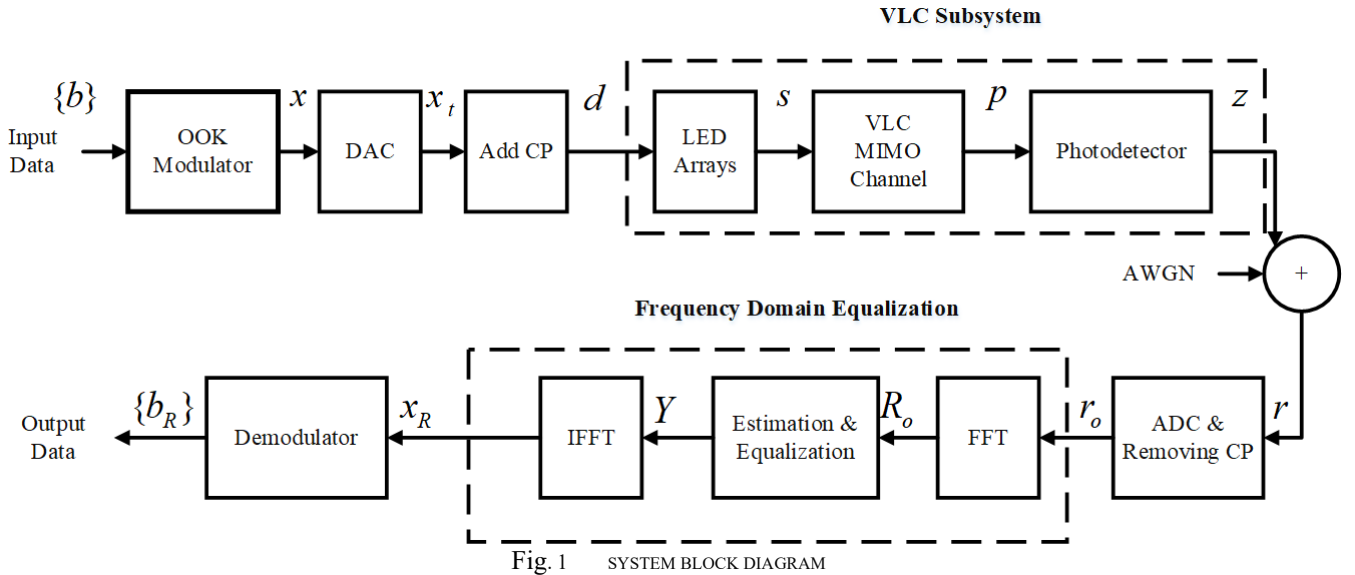

Fig. 1 SYSTEM BLOCK DIAGRAM

TABLE I SYSTEM PARAMETERS

Parameter	Value
Room dimensions	5×5×3 m <sup>3</sup>
Transmitter and Receiver distance	2.15 m
Bit rate	50 Mb/sec
Semi-angle at half power	60°
Number of LEDs	30×30
LED 3 dB cutoff frequency	10MHz
Bit numbers	10 <sup>7</sup>
Modulation	OOK
Noise Method	AWGN
MIMO 2×2 receiver positions	(0,±1.25)
MIMO 4×4 receiver positions	(±1.25,±1.25)
MIMO 2×2 transmitter positions	(0,±1.25)
MIMO 4×4 transmitter positions	(±1.25,±1.25)

based wireless systems [15]. MIMO VLC systems are investigated in several studies [16-19]. The authors in [16] investigated MIMO techniques including repetition coding (RC) and spatial multiplexing (SMP) in an indoor OWC system. In the MIMO-RC mode, all Tx's send the same data, while in the SMP mode each Tx is used to send independent data streams. It is shown that SMP improves the spectrum efficiency, while RC is more robust to Tx-Rx alignments by considering BER performance [16].

In VLC channels, ISI affects system performance, therefore to avoid ISI, OFDM may be used which instead increases PAPR. An alternative solution is utilizing SCFDE where a single carrier is used and the system does not suffer from the PAPR. In this paper, we investigate the performance of a MIMO SCFDE VLC system. Two different techniques i.e., RC and SMP are investigated by considering BER performance. In Section II we introduce the system model of the SCFDE based VLC system. Section III considers channel estimation in VLC-SCFDE followed by MIMO structures and estimation methods in Section IV. The system performance evaluation is discussed in Section V, and the results for different modes are discussed and presented. In [20] SCFDE is provided by using ray tracing in a practical MIMO VLC system with infrared (IR) LED. In this paper, an SCFDE VLC system is investigated using white light LED which has a higher cutoff frequency. Due to quasi-static

channel characteristics, we also introduce a method by which the channel is estimated only using the first frame.

## II. SYSTEM MODEL

The system block diagram is depicted in Fig. 1. In this arrangement, the system includes a transmitter employing SCFDE modulator, a MIMO VLC channel, and a receiver. System parameters are presented in Table I. The system is employed in a room with dimensions 5×5×3 m<sup>3</sup>. Transmitters positions for 2×2 scenario are (0, ±1.25), where (0, 0) is the center of the ceiling plane. In 4×4 MIMO, transmitters are positioned at (±1.25, ±1.25) while the receivers are placed at the height of 2.15 m.

### A. Transmitter

System block diagram is shown in Fig. 1. The system is considered based on intensity modulation with direct detection (IM/DD). VLC subsystem contains LED arrays, VLC channel and photodetector. In the transmitter side, an OOK modulator is utilized and the modulated data is fed into LED arrays. The modulated signal is convolved with the LED impulse response  $h_{LED}$  and a cyclic prefix (CP) is then added in order to change the linear convolution into a cyclic convolution. By employing the CP, the impacts of multipath channel and ISI are avoided. The signal is then modulated by LED where it is modeled as a low pass filter (LPF) with the impulse response  $h_{LED}(t)$ , which is given by:

$$h_{LED}(t) = \exp(-2\pi f_c t) \quad (1)$$

where  $f_c$  represents LED 3 dB cutoff frequency. The modulated signal is defined as:

$$s(t) = d(t) * h_{LED}(t) \quad (2)$$

where \* represents convolution operation.

### B. Channel

VLC channel consists of two main paths i.e. LOS, which

is the direct path between the transmitter and receiver, and NLOS which contains reflected light beams from different surfaces inside the room. The received power by the photodetector (PD) is determined by:

$$p(t) = s(t) * (h_{\text{LOS}}(t) + h_{\text{NLOS}}(t - \Delta t)) \quad (3)$$

where  $h_{\text{LOS}}(t)$  and  $h_{\text{NLOS}}(t)$ , respectively, represent LOS and NLOS channel impulse responses, and  $\Delta t$  indicates mean delay time between LOS and NLOS which is calculated based on the scenario, and is highly dependent to the room dimensions and Tx-Rx distance.

### C. Receiver

Considering additive white Gaussian noise (AWGN)  $n(t)$ , the received photocurrent is given by:

$$r(t) = p_r(t)R(t) + n(t) \quad (4)$$

where  $R$  indicates photodetector (PD) responsivity. After the PD, first the CP is removed. In this work and in order to estimate the channel, we have employed SCFDE method. In contrast to OFDM, where orthogonal frequencies are employed, in this structure a single frequency is used in order to modulate the data stream. In the receiver side, in order to estimate the channel, the received signal is converted to the frequency domain (FD) by employing the fast Fourier transform (FFT). The equalization is performed in the FD which ensures fewer multiplications. The received signal following estimation is given as:

$$Y = H_e^{-1} \times R_o \quad (5)$$

where  $H_e$  is the estimated channel frequency response (CFR),  $R_o$  is the received signal in the FD and  $Y$  is the estimated received data in the FD. Following channel estimation and equalization, the signal is converted to the time domain (TD) by using the inverse fast Fourier transform (IFFT) as given by:

$$x_R = F^{-1}\{Y\} \quad (6)$$

Then it is demodulated and finally the output data  $\{b_R\}$  is extracted.

## III. CHANNEL ESTIMATION IN SCFDE VLC

In a VLC system, due to specific and fixed channel characteristics, the channel is considered as quasi-static [3], therefore, the channel could be estimated by using the first frame, and the estimated channel response  $\hat{H}$  can then be used for next frames. In this paper, the first frame contains the pilot stream and VLC channel frequency response (CFR) including both channel and LED frequency response, is estimated using this pilot frame. The estimated VLC channel response  $H_e$  is given by:

$$H_e = \begin{pmatrix} Y_p \\ X_p \end{pmatrix}, \quad (7)$$

where  $Y_p$  and  $X_p$ , respectively, represent the FD representation of the received and transmitted pilot streams (first frame). The estimated response  $H_e$  is then utilized for equalization for next frames which contain data streams. Here, the equalization technique in the FD is zero forcing (ZF) which is described in (5). ZF is a simple linear equalizer, but increasing bit rate leads to an increase in BER. In order to

compensate for BER increase, we have used MIMO structure in this article which is discussed in Section IV.

## IV. MIMO CHANNEL

So far we have studied a SISO VLC system, but generally in a typical room, multiple LED arrays are used for lightening purposes. Thus, in a more realistic scenario, these LED arrays can be used in a MIMO VLC structure considering a system with multiple inputs. In this article, such a channel is investigated.

### A. MIMO Channel Model

The MIMO channel is modeled based on [3]. The channel transfer function is given as:

$$\mathbf{H} = \begin{pmatrix} h_{11} & \dots & h_{1N_r} \\ \vdots & \ddots & \vdots \\ h_{N_t,1} & \dots & h_{N_t,N_r} \end{pmatrix}, \quad (8)$$

where  $N_t$  and  $N_r$ , respectively, indicate transmitter and receiver, numbers.  $h_{ij}$  is the channel gain from the  $i$ th transmitter to the  $j$ th receiver and is defined as:

$$h_{ij} = \begin{cases} \sum_{k=1}^K \frac{A_{R_j}}{d_{ij}^2} R_o(\varphi) \cos(\beta_{ijk}), & 0 \leq \beta_{ijk} \leq \beta_c \\ 0, & \beta_c > \beta_{ijk} \end{cases}. \quad (9)$$

The receiver area for the  $j$ th Rx PD is shown by  $A_{R_j}$ .  $d_{ij}$  demonstrates the distance between the  $i$ th Tx and the  $j$ th Rx. The Rx field of view (FOV) and incidence angle are respectively  $\beta_c$  and  $\beta_{ijk}$ .  $\mathbf{H}$  is a  $N_t \times N_r$  matrix with  $h_{ij}$  elements. In this paper, we have considered two different MIMO techniques i.e. RC and SMP. During RC mode, all Tx's send the same data stream simultaneously. Using this mode, the system BER performance is similar to a (LOS) SISO system [16]. In SMP mode, Tx's send independent data streams [2, 16] which leads to an increase in spectral efficiency at the cost of BER increase.

### B. MIMO channel Estimation

In the RC mode, all Tx's transmit the same data stream simultaneously. The first frame contains pilots for channel estimation. The channel estimation matrix for  $2 \times 2$  MIMO is considered as:

$$\mathbf{H}_{e2 \times 2} = \begin{pmatrix} H_{e11} & H_{e21} \\ H_{e12} & H_{e22} \end{pmatrix}, \quad (10)$$

where

$$H_{eij} = \begin{pmatrix} Y_{p_j} \\ X_{p_i} \end{pmatrix}. \quad (11)$$

In this equation,  $j$  denotes the row number,  $Y_{p_j}$  is the FFT form of the received pilot by the  $j$ th Rx when transmitter number one transmits the pilot stream and  $X_{p_i}$  is the pilot stream in the FD.  $\mathbf{H}_e$  is then used to recover data, the estimated received data is given as:

$$\mathbf{X}_R = \mathbf{H}_e^{-1} \mathbf{Y}. \quad (12)$$

The signal is then converted in to the time domain as given by:

$$x_R = F^{-1}\{Y\}. \quad (13)$$

$X_R$  is then applied to the demodulator.

In SMP mode, the data stream is divided into  $N_t$  different streams and each Tx sends a different data stream, thus each Rx receives a combination of all independent data streams. Data transmission is somewhat different in this mode. For a system with  $N_t$  transmitters, channel estimation has  $N_t$  steps. A pilot stream is used with a length equal to  $1/N_t \times L$  where  $L$  represents frame length. The channel estimation matrix for  $2 \times 2$  MIMO is considered according to (9). In the first step, Tx number one sends the pilot stream, while other Tx's do not send data. At this stage,  $H_{e1,1}$ ,  $H_{e1,2}, \dots, H_{e1,N_R}$  are estimated as in (10) where  $N_R$  is the number of Rx's. This process is repeated for all Tx's and the whole matrix is estimated. Same as RC mode, the estimated signal is then converted into the TD and demodulated.

## V. SYSTEM PERFORMANCE

In an indoor OOK VLC system, SCFDE is performed for both SISO and MIMO schemes. System performance is investigated by using BER. Fig. 2 demonstrates BER vs.  $E_b/N_0$  in a VLC system for a bit rate of 50 Mb/s. Both SISO and MIMO are studied. In MIMO scheme, RC and SMP modes are investigated for  $2 \times 2$  and  $4 \times 4$  schemes.

It is observed that MIMO-RC outperforms the other methods. In MIMO systems,  $2 \times 2$  and  $4 \times 4$  schemes are considered. In MIMO-RC all Tx's send the same data, which leads to a decrease in BER compared to MIMO. For  $E_b/N_0 = 12$  dB, in  $4 \times 4$  MIMO-RC, BER is  $1.1 \times 10^{-4}$  while it is  $0.4 \times 10^{-4}$  for  $2 \times 2$ . Comparing MIMO-RC systems, it is observed that a  $4 \times 4$  MIMO configuration has a better performance than a  $2 \times 2$  MIMO. The reason is that by increasing the number of Tx's, the Tx power increases which leads to a better performance in BER. Considering  $E_b/N_0 = 12$  dB, BER in SISO scenario is  $1.2 \times 10^{-2}$ , which shows an increase compared to RC scenarios. In MIMO-SMP, Tx's send different data streams, so BER increases. In  $4 \times 4$  MIMO-SMP, for  $E_b/N_0 = 12$  dB, BER is 0.199 while for  $2 \times 2$  MIMO-SMP it is 0.089. By increasing the number of Tx's, BER increases.

In Fig. 3 system channel capacity is shown for different modes. It is observed that  $4 \times 4$  MIMO-SMP provides the highest capacity, while SISO has the lowest. In MIMO-RC all Tx's send the same data stream, but in SMP mode, data are divided into  $M_t$  streams and sent via different Tx's, therefore channel capacity increases. For  $E_b/N_0 = 12$  dB, in SISO channel capacity is 0.36 b/s/Hz, while in  $2 \times 2$  MIMO-RC and  $2 \times 2$  MIMO-SMP are, respectively, 0.4153 b/s/Hz and 0.7768 b/s/Hz. It is observed that by considering similar MIMO configurations, SMP has a higher channel capacity at the cost of BER increase. It is also shown that for  $E_b/N_0 = 12$  dB,  $4 \times 4$  MIMO-RC and  $4 \times 4$  MIMO-SMP show, respectively 1.12 and 3.54 b/s/Hz.

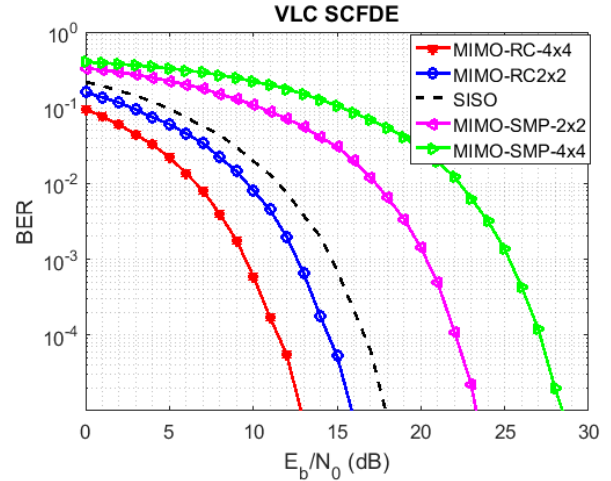

Fig. 2 BER VS.  $E_b/N_0$  – VLC-SCFDE

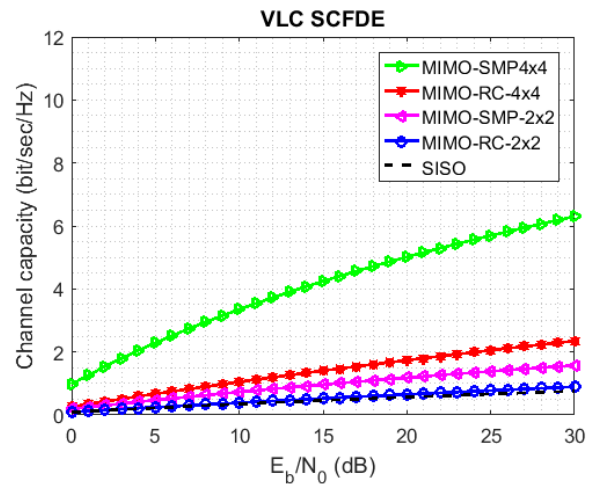

Fig. 3- Channel Capacity – VLC SCFDE

## VI. CONCLUSION

In this paper, we investigated SCFDE in a VLC system by considering OOK modulation. In VLC systems, LED performance is modeled as an LPF which limits system modulation bandwidth. On the other hand, the wireless channel consists of two main paths which leads to ISI. In this paper, we first investigated SCFDE using ZF equalizer in a SISO system. We performed SCFDE in a MIMO-VLC system. FOR MIMO structure, RC and SMP were used. In RC mode, all Tx's send the same data stream which show a better BER performance. In SMP, each Tx sends an independent data stream, where the results show an increase in BER, but spectral efficiency is also increased by factor 4. Channel capacity was also studied in this paper and it was observed that despite BER increase in SMP, channel capacity increases.

## VII. REFERENCES

- [1] Z. Ghassemlooy, W. O. Popoola, and S. Rajbhandari: Optical Wireless Communications – System and Channel Modelling with Matlab, 2 nd Ed., CRC publisher, USA, August 2019.
- [2] M. Uysal, C. Capsoni, Z. Ghassemlooy, A. C. Boucouvalas, and E. G. Udvary (Eds.): Optical Wireless Communications – An Emerging Technology, Springer, 2016

- [3] S. Dimitrov, H. Haas., Principles of LED Light Communications: Towards Networked Li-Fi., Cambridge University Press, 2015.
- [4] X. Huang, F. Yang and J. Song, "Novel Heterogeneous Attocell Network Based on the Enhanced ADO-OFDM for VLC," IEEE Commun. Lett., vol. 23, no. 1, pp. 40-43, Jan. 2019.
- [5] B. Ranjha, M. Kavehrad, "Hybrid asymmetrically clipped OFDM-based IM/DD optical wireless system", IEEE/OSA J. Opt. Commun. Netw., vol. 6, no. 4, pp. 387-396, Apr. 2014.
- [6] C.W. Chow, C.H. Yeh, Y.F. Liu, P.Y. Huang, Y. Liu, Adaptive scheme for maintaining the performance of the in-home white-LED, Optics Commun, vol 292, pp. 49-52, 2013.
- [7] Y. Sun, F. Yang and L. Cheng, "An Overview of OFDM-Based Visible Light Communication Systems From the Perspective of Energy Efficiency Versus Spectral Efficiency," in IEEE Access, vol. 6, pp. 60824-60833, 2018.
- [8] M. A. Kashani and M. Kavehrad, "On the performance of single- and multi-carrier modulation schemes for indoor visible light communication systems," 2014 IEEE Glob. Commun. Conf., Austin, TX, 2014, pp. 2084-2089.
- [9] Z. Wang, T. Mao and Q. Wang, "Optical OFDM for visible light communications," IWCMC, Valencia, 2017, pp. 1190-1194.
- [10] D. Falconer, S. L. Ariyavisitakul, A. Benyamin-Seeyar and B. Eidson, "Frequency domain equalization for single-carrier broadband wireless systems," in IEEE Commun. Magazine, vol. 40, no. 4, pp. 58-66, April 2002.
- [11] A. Nuwanpriya, J. Zhang, A. Grant, S.W. Ho, L. Luo, "Single carrier frequency domain equalization based on on-off-keying for optical wireless communications", In Wireless Communications and Networking Conference (WCNC), 2013 IEEE, pp. 4272-4277, China.
- [12] A. Nuwanpriya, S. Ho, J. A. Zhang, A. J. Grant and L. Luo, "PAMSCFDE for Optical Wireless Communications," in Journal of Lightwave Tech., vol. 33, no. 14, pp. 2938-2949, 15 July 2015.
- [13] T. Ganjian, G. Baghersalimi and Z. Ghassemlooy, "Performance evaluation of the received power based on the transmitter position in a visible light communications system," ICEE, Tehran, 2017, pp. 1763- 1768.
- [14] T. Ganjian, G. Baghersalimi, Z. Ghassemlooy, "Performance Evaluation of a VLC System when Considering the Receiver's Orientations," WACOWC, Isfahan, 2018.
- [15] A. Goldsmith, "Wireless communications", Cambridge university press, 2005.
- [16] T. Fath and H. Haas, "Performance Comparison of MIMO Techniques for Optical Wireless Communications in Indoor Environments," in IEEE Trans. on Commun., vol. 61, no. 2, pp. 733-742, February 2013.
- [17] A. Burton, H. Le Minh, Z. Ghassemlooy, E. Bentley and C. Botella, "Experimental Demonstration of 50-Mb/s Visible Light Communications Using 4x4 MIMO," in IEEE Photonics Tech. Lett., vol. 26, no. 9, pp. 945-948, 2014.
- [18] P. F. Mmbaga, J. Thompson, and H. Haas, "Performance analysis of indoor diffuse VLC MIMO channels using angular diversity detectors," J. Lightw. Technol., vol. 34, no. 4, pp. 1254-1266, Feb. 2016.
- [19] Z. Feng, C. Guo, Z. Ghassemlooy and Y. Yang, "The Spatial Dimming Scheme for the MU-MIMO-OFDM VLC System," in IEEE Photonics Journal, vol. 10, no. 5, pp. 1-13, Oct. 2018, Art no. 7907013.
- [20] O. Narmanlioglu, B. Turan, R. C. Kizilirmak, S. C. Ergen, M. Uysal, "SC-FDE Based MIMO Uplink Transmission over Infrared Communication Channels," (VTC-Fall), Chicago, 2018.