

Northumbria Research Link

Citation: Warburton, Nina Christine (2001) The impact of three dimensional digital modelling media on the modes of communication used by industrial designers. Doctoral thesis, University of Northumbria at Newcastle.

This version was downloaded from Northumbria Research Link:
<https://nrl.northumbria.ac.uk/id/eprint/15756/>

Northumbria University has developed Northumbria Research Link (NRL) to enable users to access the University's research output. Copyright © and moral rights for items on NRL are retained by the individual author(s) and/or other copyright owners. Single copies of full items can be reproduced, displayed or performed, and given to third parties in any format or medium for personal research or study, educational, or not-for-profit purposes without prior permission or charge, provided the authors, title and full bibliographic details are given, as well as a hyperlink and/or URL to the original metadata page. The content must not be changed in any way. Full items must not be sold commercially in any format or medium without formal permission of the copyright holder. The full policy is available online: <http://nrl.northumbria.ac.uk/policies.html>

Some theses deposited to NRL up to and including 2006 were digitised by the British Library and made available online through the [EThOS e-thesis online service](#). These records were added to NRL to maintain a central record of the University's research theses, as well as still appearing through the British Library's service. For more information about Northumbria University research theses, please visit [University Library Online](#).



**Northumbria
University**
NEWCASTLE



University**Library**

**The Impact of Three Dimensional Digital Modelling
Media on the Modes of Communication
used by Industrial Designers**

NINA CHRISTINE WARBURTON

A thesis submitted in partial fulfilment
of the requirements of the
University of Northumbria at Newcastle
for the degree of

DOCTOR OF PHILOSOPHY

School of Design
University of Northumbria at Newcastle

November 2001

UNIVERSITY OF NORTHUMBRIA AT NEWCASTLE LIBRARY	
ITEM No.	CLASS No.
20 050 211 48	745.401 WAR

ABSTRACT

“An investigation into the impact of 3D digital modelling media on industrial designers’ internal and external modes of communication.”

Effective communication in product design facilitates effective decision-making, which in turn is essential to a successful design process. The medium of communication is therefore likely to influence the decision making process, making the appropriate selection of media key to the progress of a project. Based on this premise, this study investigates the impact that 3D digital media is having on designers’ internal and external modes of communication, in association with other media tools and techniques which are used.

Analysis of a range of commercial product design case studies has enabled the creation of a tool assisting both the practice of industrial designers or the teaching of the use of 3D digital media to industrial design students. The tool helps designers appreciate the tactical application of digital technologies, to establish how, when and why digital media might be employed as a communication tool within the design process.

Action Research methodologies were drawn on to develop a research framework for the study. This comprised three core elements: reflective practice, reflection on practice, and reflection on reflective practice. The data derived from these supported the methods used for case study compilation and cross-case analysis.

The tool for practice takes the form of a heuristic map, intended to help the industrial designer understand the appropriate use, and integration of, traditional and digital media throughout the design process. Central to this understanding is the premise that it is just as important to design practice to consider 3D digital media as a tool for communication, as well as for design.





The study seeks to build a bridge between theory and practice, through the amalgamation of practitioner based research and qualitative observational research methods. Publication of the findings via a CD & website contribute to the accessibility of the process and findings of the research investigation.







TABLE OF CONTENTS

Abstract	i
Contents	ii
List of figures	viii
Acknowledgements	xi
Preface.....	xiii
1.0 INTRODUCTION	2
1.1 Introduction	2
1.2 The Design Process	5
1.3 The Relevance of CAD	6
1.3.1 The Concept of CAID	7
1.3.2 CAID & Digital Media.....	8
1.4 Why Research?.....	8
1.5 The Visual Nature of the Project.....	10
1.6 Aims & Objectives	11
1.6.1 The Projected Outcomes	14
2.0 PROJECT CONTEXTUALISATION & FORMATIVE RESEARCH	17
2.1 Introduction	17
2.2 The Historical & Technological Context.....	18
2.2.1 Digital Technologies & Manufacturing.....	20
2.2.2 Digital Technologies & Industrial Design Consultancy Practice	21
2.2.3 Digital Technologies & Design Research.....	24
2.3 Models of the Design Process.....	27
2.3.1 History	27

2.3.2 Prescriptive Models.....	28
2.3.3 Descriptive Models.....	29
2.3.3.1. Cyclic Models.....	30
2.3.4 New Product Development Models.....	32
2.3.5 The Relevance of Design Process Models.....	33
2.4 Related Work.....	33
2.4.1 Broad relevance.....	34
2.4.2 Specific relevance.....	35
2.4.3 Practical relevance.....	38
2.5 Design Practice V Design Research - The relative value of this project.....	38
2.5.1 What it means to be a design practitioner in design practice.....	38
2.5.2 What it means to be a design researcher in design research	39
2.5.3 The conflict between design practice & design research	40
2.6 Formative Research.....	41
2.6.1 Pilot Study	41
2.6.1.1. Subject Familiarisation.....	42
2.6.1.2. Which Solid Modeller?	42
2.6.2 Software Interface Assessment	44
2.6.3 The Contribution of the Pilot Study to the Research Decision Making	46
2.6.4 Formative Case Studies 	47
2.6.4.1. Case Study 1: Seaward Electronics.....	47
2.6.4.2. Case Study 2: Daniel Thwaites Ltd.....	48
2.6.5 Formative Research Findings.....	51
3.0 METHODOLOGY.....	62
3.1 Introduction	62
3.2 The Historical Development of Design Methodology	63
3.2.1 The Management of the Design Process	63

3.2.2 The structure of design problems.....	65
3.2.3 The nature of design activity.....	66
3.2.4 The philosophy of design methods.....	67
3.2.5 Summary.....	67
3.3 Review of methodologies for practice-based research.....	68
3.3.1 What is research?.....	68
3.3.2 Scientific & Humanities Research.....	69
3.3.3 Practitioner Based Research.....	71
3.3.3.1. Action Research.....	71
3.4 Action Research as a Proposed Methodology.....	74
3.4.1 Rationale.....	74
3.4.2 Case Studies & Action Research.....	76
3.4.3 Research objectives and relationship to action research.....	79
4.0 CASE STUDIES & CASE STUDY ANALYSIS.....	88
4.1 Introduction.....	88
4.1.1 The case studies.....	88
4.2 Methodology.....	91
4.2.1 Types of Case Study.....	93
4.3 Case Study Compilation.....	94
4.3.1 Section 1: Documentary evidence.....	95
4.3.2 Section 2: Visual Evidence.....	96
4.3.3 Section 3: Index 	97
4.3.3.1. Design Stage.....	98
4.3.3.2. Importance.....	98
4.3.3.3. Year/Month/Day.....	98
4.3.3.4. Activity.....	99
4.3.3.5. Source.....	99

4.3.3.6. Media Type / Definitions		99
4.3.4 Section 3: Narrative		99
4.4 The Case Studies		100
4.4.1 Case Study 1. Bi-Liquid Mixing System		100
4.4.1.1. The Brief		100
4.4.1.2. The Result		100
4.4.1.3. The Process		101
4.4.2 Case Study 2. Soulagil		104
4.4.2.1. The Brief		104
4.4.2.2. The Result		105
4.4.2.3. The Process		105
4.4.3 Case Study 3. Medis		108
4.4.3.1. The Brief		108
4.4.3.2. The Result		109
4.4.3.3. The Process		110
4.5 Case Study Analysis		113
4.5.1 Introduction		113
4.5.2 Methodology		115
4.5.2.1. Case Study Design		115
4.5.2.2. Analysis methods		117
4.5.3 Cross Case Analysis Techniques & Methods		119
4.5.3.1. Variables within Pattern Matching		120
4.5.4 Selection of analysis methods		121
4.5.4.1. The Analysis Variables		122

4.5.5 The Hypothetical Integration Map.....		123
4.5.5.1. The development of the hypothetical integration map		123
4.5.5.2. Outcomes		128
4.5.6 Cross Case Analysis.....		130
4.5.6.1. Individual Case Studies – detailed analysis		130
4.5.6.2. Individual Case Study – simplified analysis		131
4.5.6.3. Cross Case Analysis – the cross case map		134
4.5.7 Cross Case Analysis: synthesis & findings		138
4.5.7.1. Adopting an appropriate design process model.....		139
4.5.7.2. The Creation of Design ‘Actions’		143
4.5.7.3. Generalising the forms of communication.....		146
4.5.7.4. Defining the characteristics of the media.....		147
4.5.7.5. The Final CCA Map		153
5.0 THE HEURISTIC MAP.....		159
5.1 Introduction		159
5.2 A Heuristic Map for Digitally Integrated Design		159
5.2.1 A model or a map?		160
5.2.2 The Map: Objectives		161
5.2.3 The Map: Key considerations		162
5.2.4 Format.....		163
5.3 The Structure of the Map		164
5.3.1 The core results of the heuristic map.		166
5.3.2 Peer Review		172

5.3.2.1. Qualifications.....	173
5.3.2.2. Feedback.....	174
5.3.2.3. Findings	174
6.0 CONCLUSIONS.....	177
6.1 Introduction	177
6.2 What does the map tell us?.....	178
6.3 Reflection on a practice based research programme.....	182
6.3.1 The methodological approach.....	182
6.3.2 The Value of Practice Based Research.....	185
6.3.3 Validity of the timeframe	186
6.3.4 Trends in design research.....	186
6.3.5 Contribution of the research process to the advancement of practice.....	188
6.4 Contribution to Knowledge.....	189
6.5 Restrictions and limitations.....	190
6.5.1 Current trends in the use of 3D digital technologies	190
6.5.2 Limitations of the Heuristic Map.....	192
6.5.3 Limitations of the Thesis.....	193
6.6 Further Work	194
BIBLIOGRAPHY.....	197
GLOSSARY.....	205

LIST OF FIGURES

<i>Number</i>	<i>Page</i>
Fig. 1. Final computer visualisations of amplifier probe (left) and oscillator (right) concepts.	48
Fig. 2. Early computer visualisations showing the two concepts with graphics	49
Fig. 3. Final computer visualisation showing the selected concept with final graphics in context	50
Fig. 4. The ideal application of an Action Research methodology to the research programme.	91
Fig. 5. The actual application of a partial Action Research methodology to the research programme.	92
Fig. 6. A section of the Mixing System case study index	97
Fig. 7. Final mouldings – mixing system	101
Fig. 8. Mixing system: Initial Concepts	102
Fig. 9. Mixing system: Design Development A	103
Fig. 10. Mixing system: Design Development B	103
Fig. 11. Mixing system: Design Development C: Final Specification	103
Fig. 12. Mixing system: Communicating the design to external parties	104
Fig. 13. Soulagil: Computer Visualisation of the final design	105
Fig. 14. Soulagil: Initial Concepts	106
Fig. 15. Soulagil: Concept Development	106
Fig. 16. Soulagil: Concept Presentation	107
Fig. 17. Soulagil: Concept using a modified actuator and a standard bottle	107
Fig. 18. Soulagil: Specification Development	107
Fig. 19. Medis: Existing product (left), final product (right)	109

Fig. 20. Medis: Research	110
Fig. 21. Medis: Initial Concepts	111
Fig. 22. Medis: Concept Development – Asymmetrical Concept	111
Fig. 23. Medis: Concept Presentation	111
Fig. 24. Medis: Final Design Proposal	112
Fig. 25. Medis: Corporate Identity Proposals	112
Fig. 26. Medis: Final Product & Specification	112
Fig. 27. Case study method (in black) shown amalgamated with the research method adopted by this study (in red)	118
Fig. 28. The basic form of the Hypothetical Integration Map	125
Fig. 29. The Hypothetical Integration Map – simplified form	126
Fig. 30. Final Hypothetical Integration Map	127
Fig. 31. Stage 1 of the Bi-liquid mixing system individual detailed analysis map	132
Fig. 32. Stage 1 of the Bi-liquid mixing system simplified analysis map	133
Fig. 33. Scoring system from simplified maps	134
Fig. 34. A spreadsheet collects data re. instances of media.	135
Fig. 35. Refining the CCA data: Step 1	136
Fig. 36. Refining the CCA data: Step 2.	136
Fig. 37. Stage 1 of the core CCA map	137
Fig. 38. Matrix illustrating similarities between design process models.	141
Fig. 39. Extended matrix illustrating derivation of design ‘actions’	145
Fig. 40. Characteristics of media	148
Fig. 41. Stage 1 of the final CCA map	154
Fig. 42. The first step in navigating the map is to select a design action	164
Fig. 43. The second step is to select a communication type	164

Fig. 44. The third step is to select a media type available for that action and that communication type	165
Fig. 45. The fourth step displays the Characteristics and Use Summary (illustrated in Fig. 46)	165
Fig. 46. An example of a Characteristics and Use Summary page within the Heuristic Map	169

ACKNOWLEDGMENTS

The completion of this thesis has followed a long road and there are a number of people without whom it would not have been possible.

First of all I would like to thank my Director of Studies, Dr. Robert Young at the Centre for Design Research (CDR) at the University of Northumbria at Newcastle. For his patient and careful supervision, advice, editing, contributions and continual faith in my ability to make this thesis happen. Also, then to all the staff at the CDR, for their general practical assistance in helping me get things done, and especially to those who enabled the heuristic map to be on the Centre for Industrial Design (CfID) website. I would also like to thank the staff at the School of Design for all their help and encouragement over the years.

I would also like to thank my external supervisor, Professor Harold Thimbleby at Middlesex University. Again for his patience and good humour, not to mention his wealth of experience which he used to guide me through the execution and writing up of the project.

None of the work would have been possible without the assistance of the staff, clients and associates of the Centre for Industrial Design. In particular I would like to thank Brian Wilson, my former second supervisor. Also, I would like to thank the clients who enabled the case studies to be carried out in the first place: Seaward Electronics, Thwaites Breweries, the NHS in Scotland and Procter & Gamble as well as a major pharmaceutical company. I would also like to thank my former research partner at the CfID, Kevin McCullagh, for all his advice and contributions.

In the latter years I have received significant amounts of support from my new employers at Random Product Design and Alloy Total Product Design. I would

specifically like to thank Gus Desbarats & Nick Vessey for their support and for giving me invaluable study time when I needed it.

I would like to thank all my friends and family for never giving up their faith in me.

Last, but by no means least I would like to thank my husband Sebastian. His consistent patience, support, feeding, cajoling and commitment to this project have been a tower of strength. I couldn't have done this without him.

PREFACE

This thesis is based on an investigation carried out within the Centre for Industrial Design (CfID), a research-led design consultancy based within the Centre for Design Research (CDR) at the University of Northumbria at Newcastle (UNN). The resources for the programme were, for the main body of the investigation, those provided within the Centre for Industrial Design and the central libraries at UNN.

This programme has sought to constantly benchmark its progress against that of others. This has been done in part through the publication and presentation of papers in journals, conferences and seminarsⁱ, however there have also been a number of factors and events that have served to shape and influence this thesis.

Project Circumstances

In 1990 the Department of Design at UNN invested in a three-dimensional (3D) surface modeller, Alias, running on a Silicon Graphics Workstationⁱⁱ. As Course Leader of the Design for Industry (DFI) course, my now Director of Studies, Dr Robert Young, was quick to realise that involvement with a research culture was essential for the long term future of the subject area and further, that the use of 3D computing in design was an area that would require significant research attention. At the same time, one of the senior lecturers, Brian Wilson, was promoting the idea that the course needed to have a more formal basis for its as then ad hoc. consultancy

ⁱ WARBURTON, N. *What have we learnt so far about using computers*, at Networking Design, Design for Industry Course Conference, UNN, March 21, 1996.

WARBURTON, N. *Digital Integration & Designer Tactics*. CADE Postgraduate Conference, Coventry University, March 26, 1996.

WARBURTON, N. A Heuristic Model for Digitally Integrated Design, in *Co-Design Journal*, 07.08.09, 1996, p. 22-27.

WARBURTON, N. *The Integration of the Digital in the Design Process*, at Multi-Viewpoint, Shaping the Human Computer Interface, DRS Seminar, UNN, July 2, 1998.

ⁱⁱ Workstation: see Glossary

activities. The CfID was set up the following year with a remit to expand both the consultancy and research activities of the department.

I joined UNN as a research associate in early 1992, along with my then research partner, Kevin McCullagh. We had a dual role: one, to assist the CfID in establishing its consultancy activities, and two, to engage in active research into the use of 3D computing technologies in industrial design. As graduate designers we were naïve as to the requirements of formal research and the process of coming to terms with the requirements presented many challenges. I believe that there are two main reasons for this: in the first instance, a vocational design degree does not prepare you for the more technical aspects of research and study; second and perhaps more importantly, we were among the first of a new wave of design researchers for whom there were fewer practical or methodological precedents than in the more established research fields such as science or the humanities.

Before long, the commercial pace in the Centre began to quicken, with the research/design team undertaking a range of commercial design contracts. The Centre promoted itself as a research-led design consultancy with the majority of these commercial contacts established due to an interest in working with new computer aided design (CAD) technologies. The execution of these contracts through the implementation of CAD became our core area of interest and the basis upon which we promoted our activities. It quickly became apparent that research and practice had to work hand in hand, for practice to draw from the findings of research and vice versa.

The CfID had originally been based within the environment of the DFI course, however the demand for space, a need for a more professional environment and increasing pressure for confidentiality led to the Centre moving to self contained offices within the department by the end of 1994. As the business grew, the physical hardware resource base, as well as the personnel base, increased rapidly. Not only were we accommodating more researchers, but had employed a number of designers

who had no formal research remit. The CfID had become a fully independent cost centre and a fully functioning industrial design consultancy.

Influencing events

The Centre had established a strong and valuable symbiotic relationship between research and practice, but prioritisation between commercial and research activities was a constant issue. On a personal level, as a senior member of staff responsible for project management, this constrained the time available to conduct my research programme, which tended to be concentrated into intensive periods of activity. Commercial pressures continued to pressure the symbiotic relationship between practice and research and towards the end of 1996, the situation was resolved when the more commercially oriented staff in the CfID formed a spin-out design consultancy as part of a large engineering group.

With the main investigative phase of the study complete, I decided that my future was to be in an alternative commercial domain and, in April 1997 I joined an established design consultancy, Random Product Design, as a senior designer. Random were already heavy users of 3D CAD and had been running Solid Designerⁱⁱⁱ for some years. At the time I joined they were converting to a new modeller: Unigraphics^{iv}, which combines the use of solid and surface modelling in a single package. Working with these new packages within a different design culture provided me with further insights, many of which have influenced this thesis. Inevitably, the demands of my new job were significant and the writing up of the research programme was delayed as a result, however, this is offset by the opportunity for a wider view and further reflection about its outcomes. Another event to affect the research programme occurred in January 1999, when Random was liquidated under the direction of its parent company, Random Group plc. A few months later the majority of the staff of Random set up a new company, Alloy Total

ⁱⁱⁱ Solid Designer: see Glossary

^{iv} Unigraphics: see Glossary

Product Design, of which I am currently a director. Alloy's working practices are focused around the use of 3D CAD as a core tool, providing yet further insights for the research programme.

Despite initial concerns, the extended time span of the research programme has added significant depth and value to the outcomes of the project. This has enabled the research to adopt a more realistic perspective on the impact that digital technologies have had on the industrial design profession than a more fast-track programme may have done. Having worked with and developed methods for the use of these technologies within three different companies, I have found that although over time techniques and software have changed, the core thinking remains remarkably similar to that of the early 90's. In addition to this I would argue that this programme presents an important insight into the issues and problems surrounding carrying out true research within a truly commercial context, which is constantly changing and unpredictable.

Supporting visual material

This thesis consists of two core elements: a written document and an interactive CD. Due to the extensive amount of visual information that supports the thesis, the parallel viewing of the CD is essential to the full understanding of the thesis. A requirement to view the CD is indicated by the use of a CD icon next to the relevant section heading. This will be illustrated more fully in the following section.

How to use the CD

The CD can be viewed using an Internet browser, i.e. Netscape Navigator or Internet Explorer, versions 4 and above. There are two versions of the CD, one to be viewed via a PC, the other via an Apple Macintosh.

To view the CD, load the appropriate CD type (Mac or PC) into the drive, the CD will launch automatically, showing the title page as shown on the following page

(top left). Click on the arrow to continue. If the CD does not launch automatically, open an appropriate browser and open the file CD\intro\html\index.html.

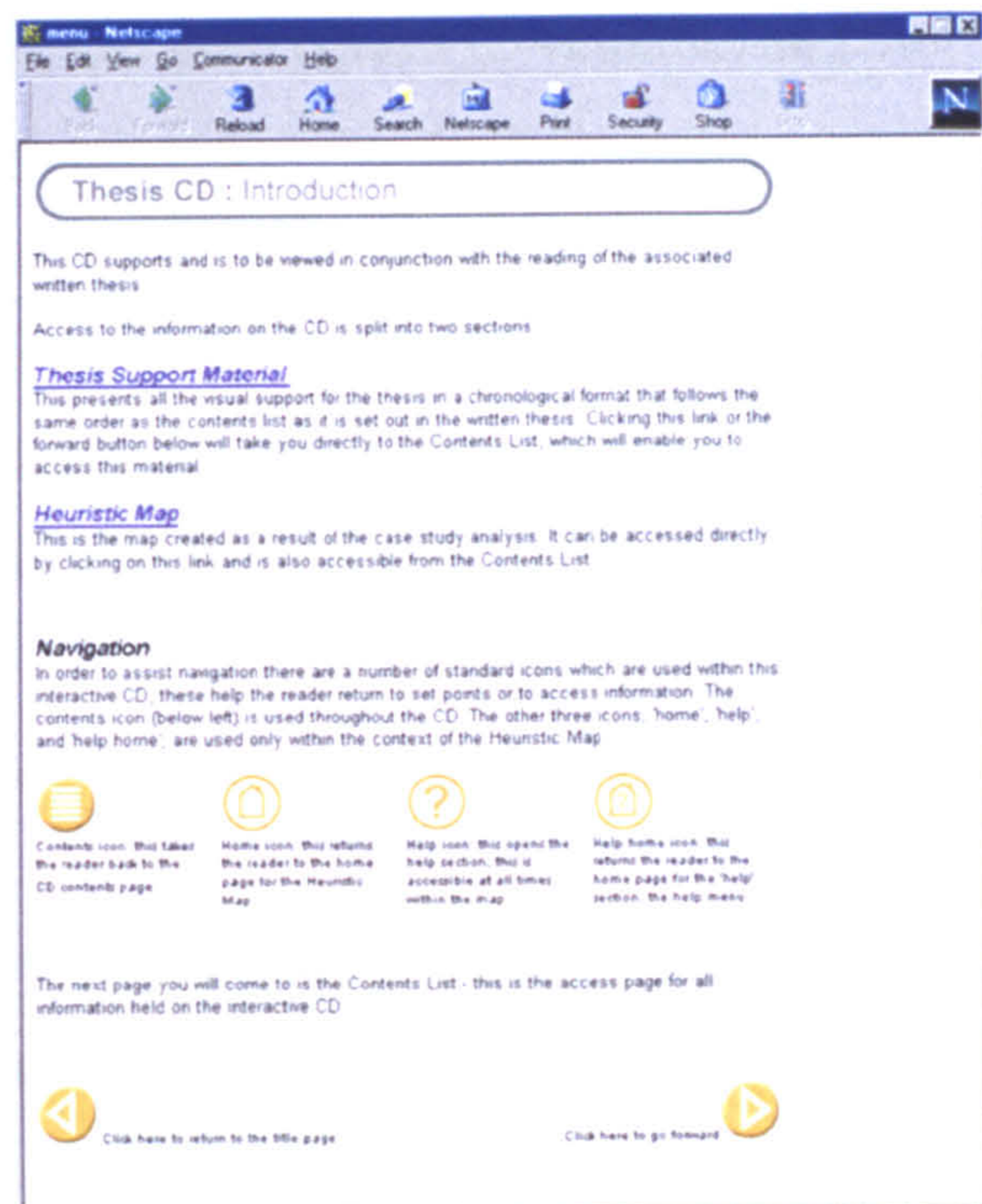
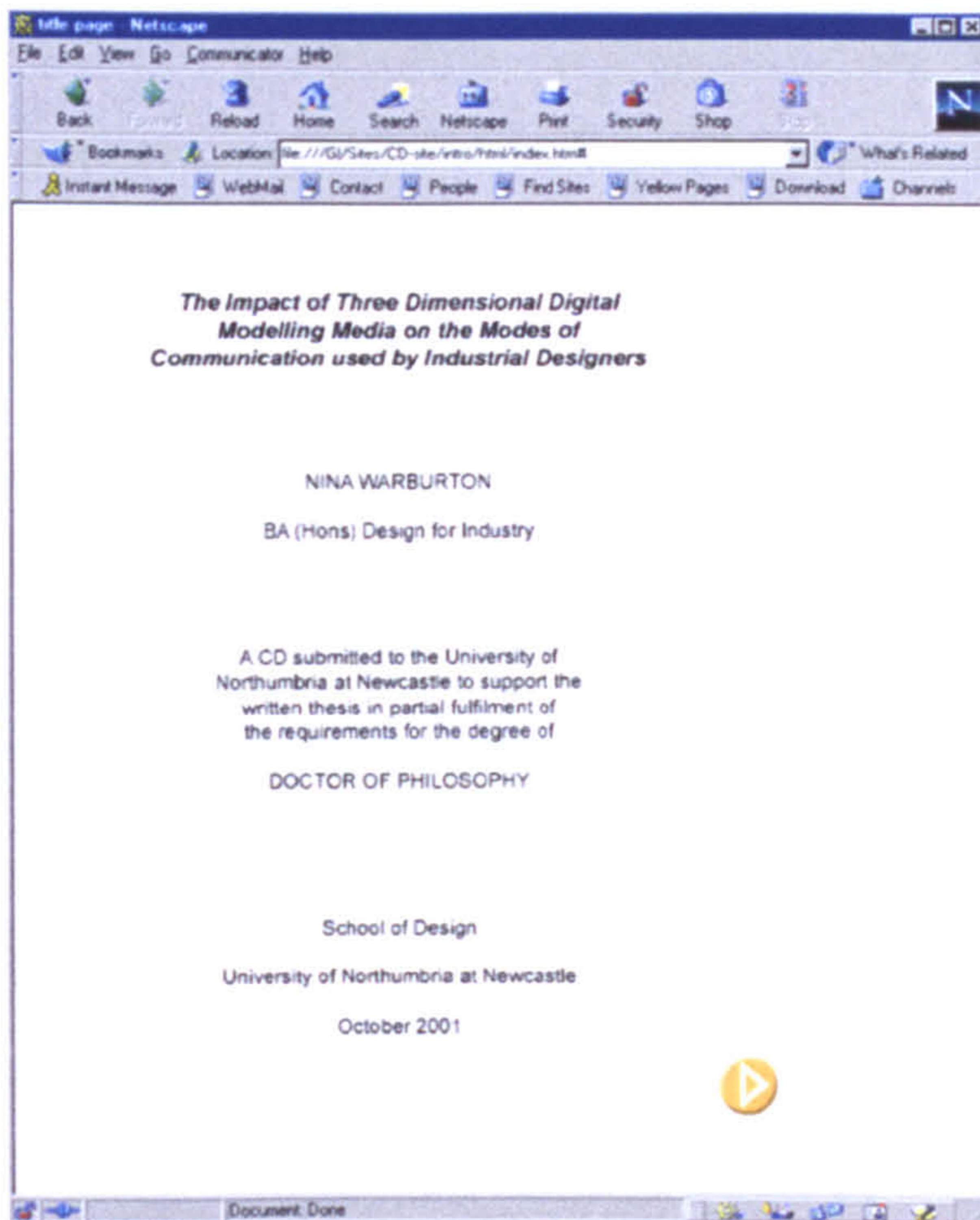

You will then be presented with a page that gives the reader some important information about the presentation of the CD material and explains the use of a series of simple icons (above right). Click on the forward arrow to continue.



The reader will then be presented with the contents list (left), this list has the same numbering system as the main thesis, but is truncated to show only elements that have material on the CD.

The cue to view the CD is the inclusion of the CD icon next to a section heading, as illustrated by (1 - top left). When the reader sees this icon, they should click on the corresponding number/section heading on the CD contents list (2 - middle) and the appropriate material will be displayed (3 - bottom left).

4.4.1. Case Study 3: Medis

Client: Department of Health, Scotland
Product: Medis
Project: The design of a terminal and associated interface to allow patients to access their personal medical records held on an optical card.

There follows a summary or overview of the events which occurred during the execution of the project named 'Medis'. The project was carried out by the Centre for Industrial Design on behalf of the Department of Health in Scotland and spanned a timescale between April 7th 1994 and January 24th 1996, however the core work was carried out between 23rd July 1994 and 15th June 1995. This project was slightly different to the other case studies in that it comprised the design of both hard and soft entities, a product and interface. The focus of this case study is the design of the product.

4.4.1.1 The Brief
 The project was linked to a research programme which, in response to government legislation, was assessing the effect of allowing patients to have access to their personal medical records via an optical card. The information on the cards was accessible via a standalone terminal. The client's opinion was that the existing unit, which had been described unflatteringly as a 'brown steel coffin' was having an adverse effect on the findings. The Centre for Industrial Design was commissioned to design a more appropriate unit, which had to contain a number of pre-determined hardware components and had to allow for a range of use and environmental situations. The Centre was further commissioned to redesign the interface which had to be sympathetic to the needs of the end user, be simple to use and easy to understand. Both the interface and the unit had to be friendly whilst retaining user confidence in the accuracy and security of the information presented.



When see this icon

1

Click Here

2

Contents List (truncated)

This is the contents list. It is a truncated version of the list shown in the written thesis. It shows only aspects of the list that have some associated visual content. Click on the links below to access this visual material. Click on the contents page icon (top right) at any time to return to this page.

- 1.0 INTRODUCTION (no CD material)
- 2.0 PROJECT CONTEXTUALISATION & FORMATIVE RESEARCH
 - 2.0 Formative Research
 - 2.0.1 Computer Case Studies
- 3.0 THE METHODOLOGY (no CD material)
- 4.0 CASE STUDIES AND CASE STUDY ANALYSIS
 - 4.0 Case Study Completion
 - 4.0.1 Section 3 Case Study Introduction
 - 4.1 Case Studies
 - 4.1.1 Case Study 1: Bi-liquid mixing system
 - 4.1.2 Case Study 2: Squalid
 - 4.1.3 Case Study 3: Medis
 - 4.5 Cross Case Analysis
 - 4.5.1 The Hypothetical Integration Map
 - 4.5.2 The Development of the Hypothetical Integration Map
 - 4.5.3 Cross Case Analysis
 - 4.5.3.1 Industrial Case Studies: squalid analysis
 - 4.5.3.2 Industrial Case Studies: biomedical case study
 - 4.5.3.3 Case Study Analysis
 - 4.5.4 Cross Case Analysis: synthesis & findings
 - 4.5.5 The Final ICM Map
- 5.0 THE HEURISTIC MAP
 - 5.2 A Heuristic Map for Digitally Integrated Design
 - 5.3 The Structure of the Map
- 6.0 CONCLUSIONS (no CD material)

Click here to return to the introduction

3

4.4.3. Case Study 3: Medis

Concept Generation Design Development Specification

Planning & Research

Initial Concept Generation

To View This

How to use the Heuristic Map

Click on the contents list heading: 'A heuristic map for digitally integrated design'.

Following a short introduction (click on 'continue' to proceed), there follows a description of how to navigate the map step by step (below).

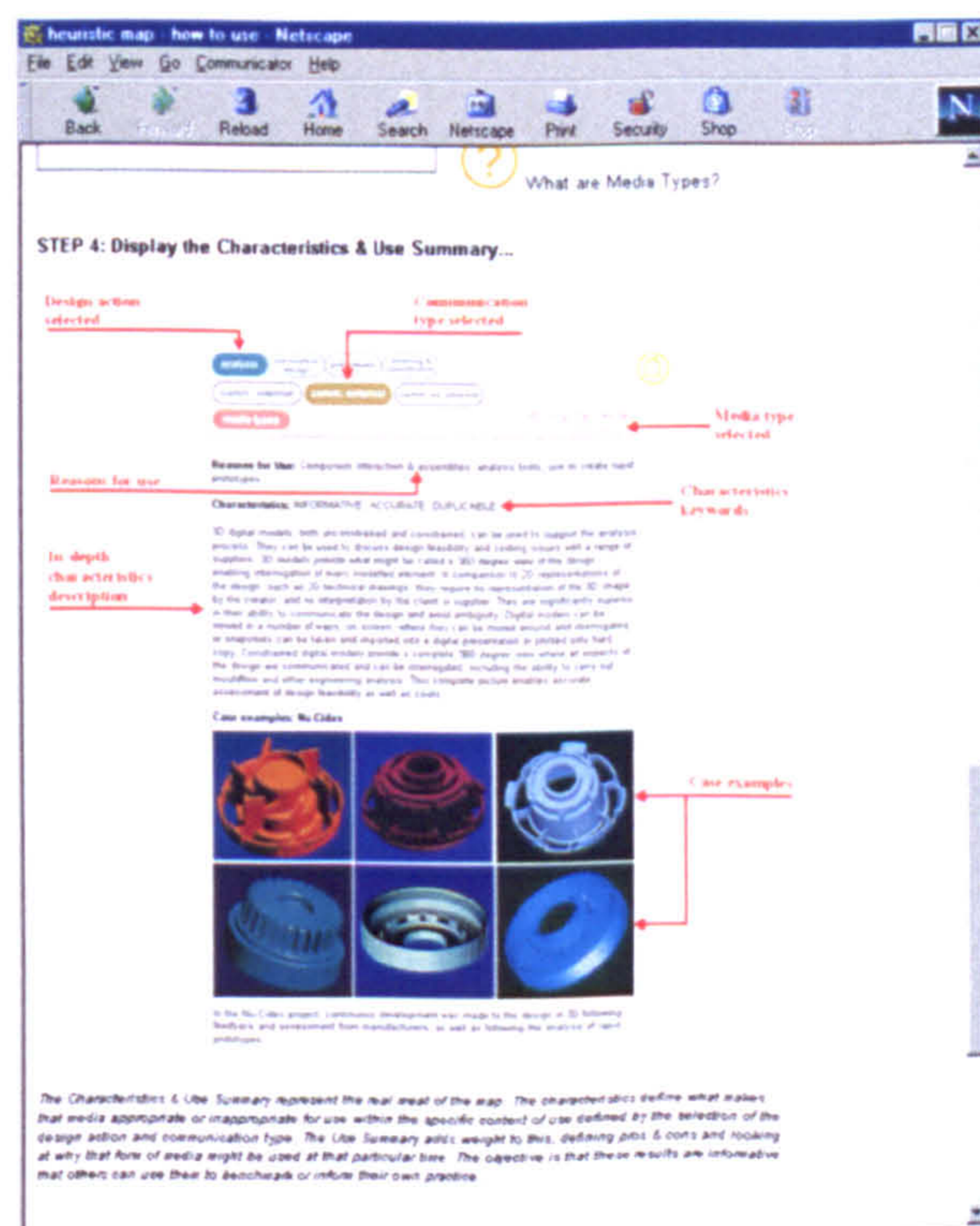
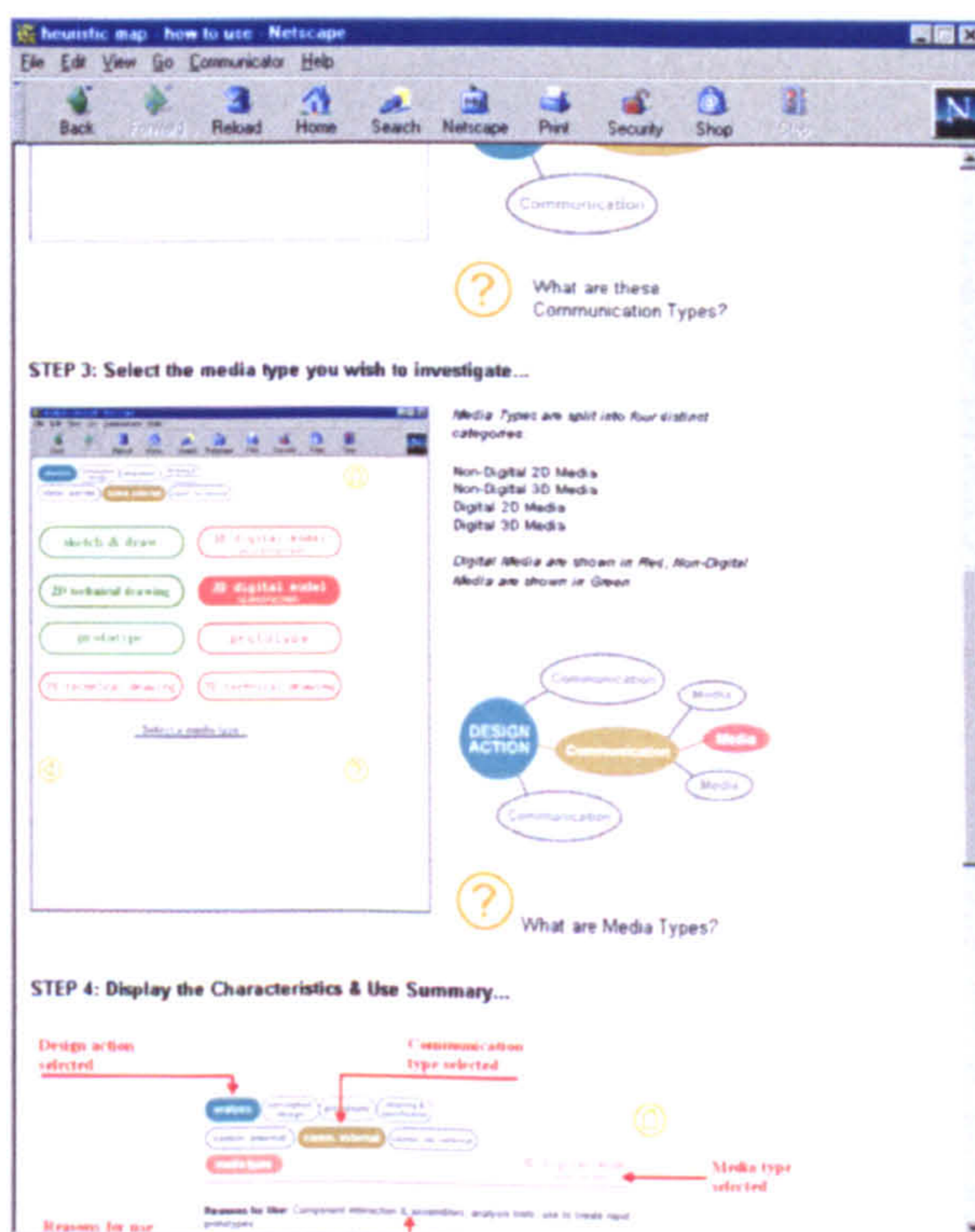
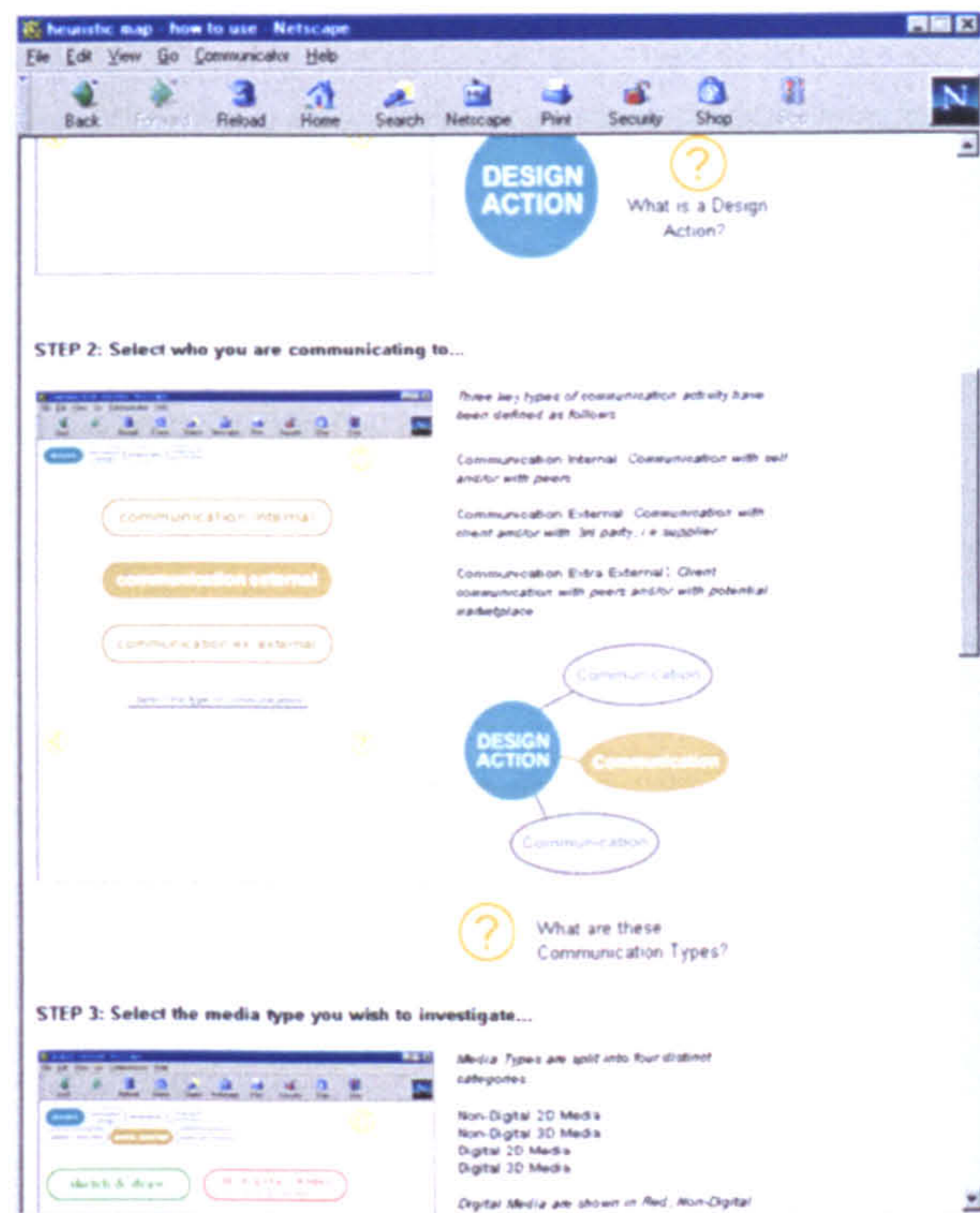
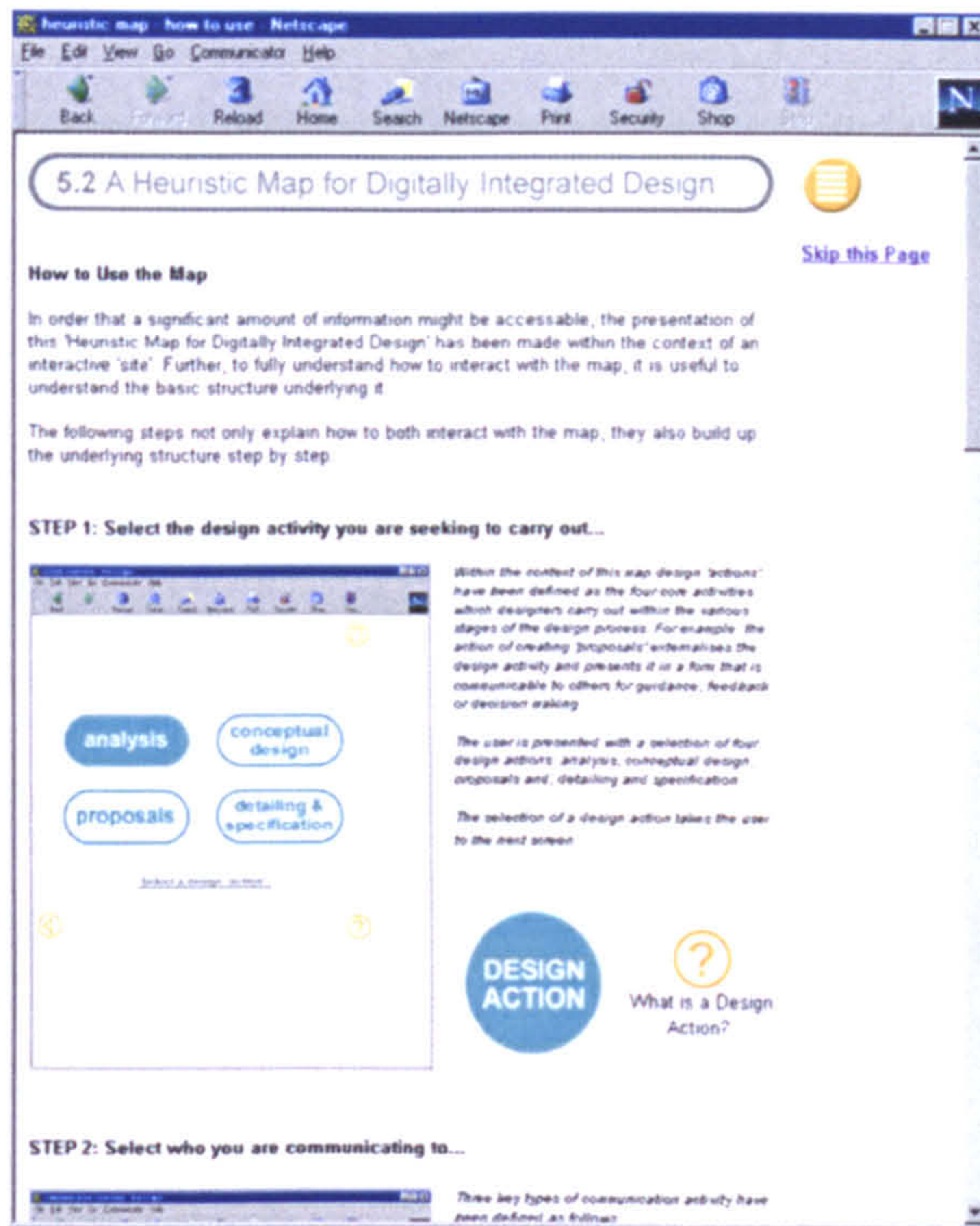

At any point in the heuristic map there is the opportunity to view a series of help pages, these describe various aspects of the map in more detail and include information on: the thesis abstract, the case studies and a map guide. There is also an explanation of some of the terminology used in the map such as ‘design actions’, ‘communication types and ‘media types’. The help contents page and a sample from one of the help pages are illustrated below.

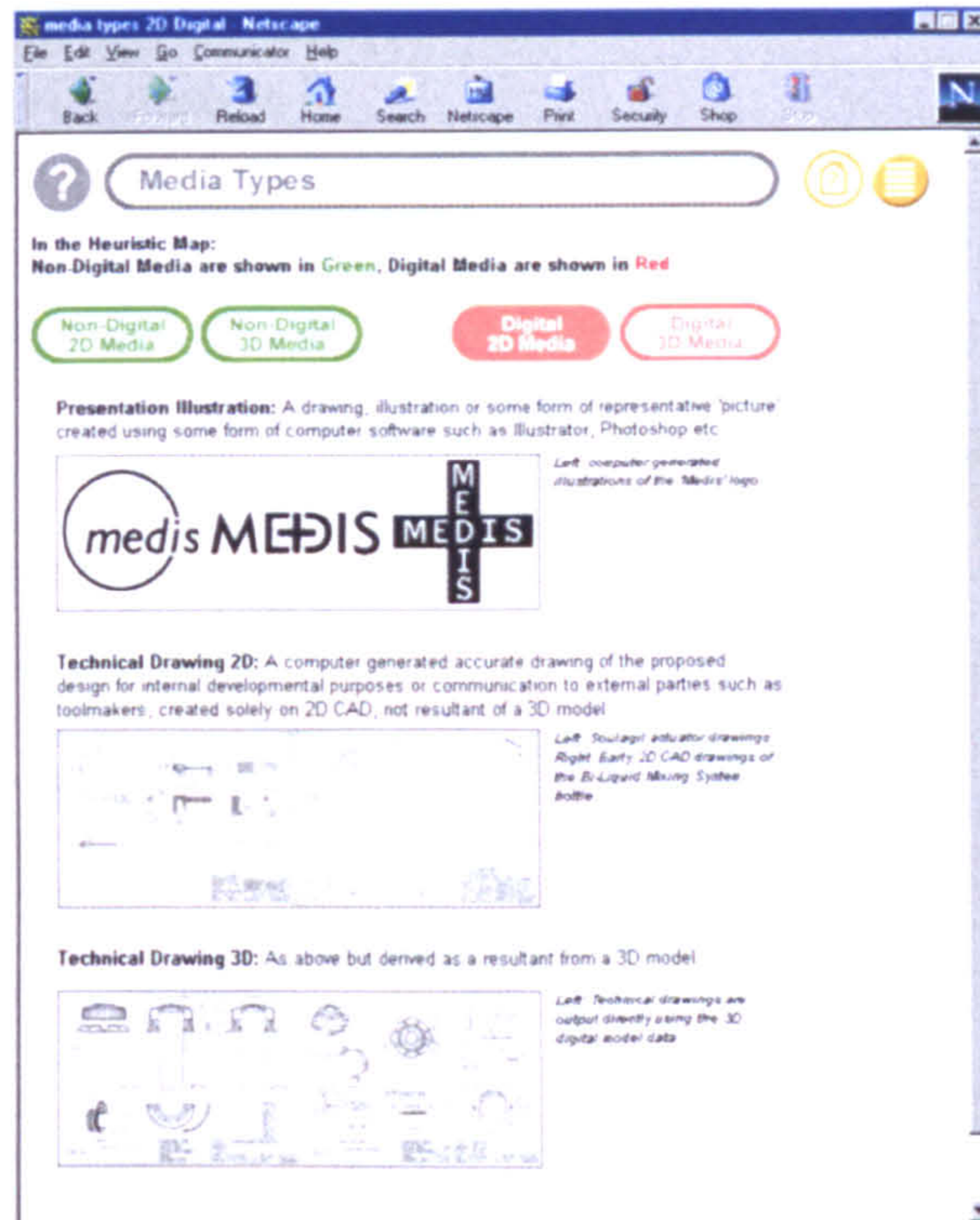
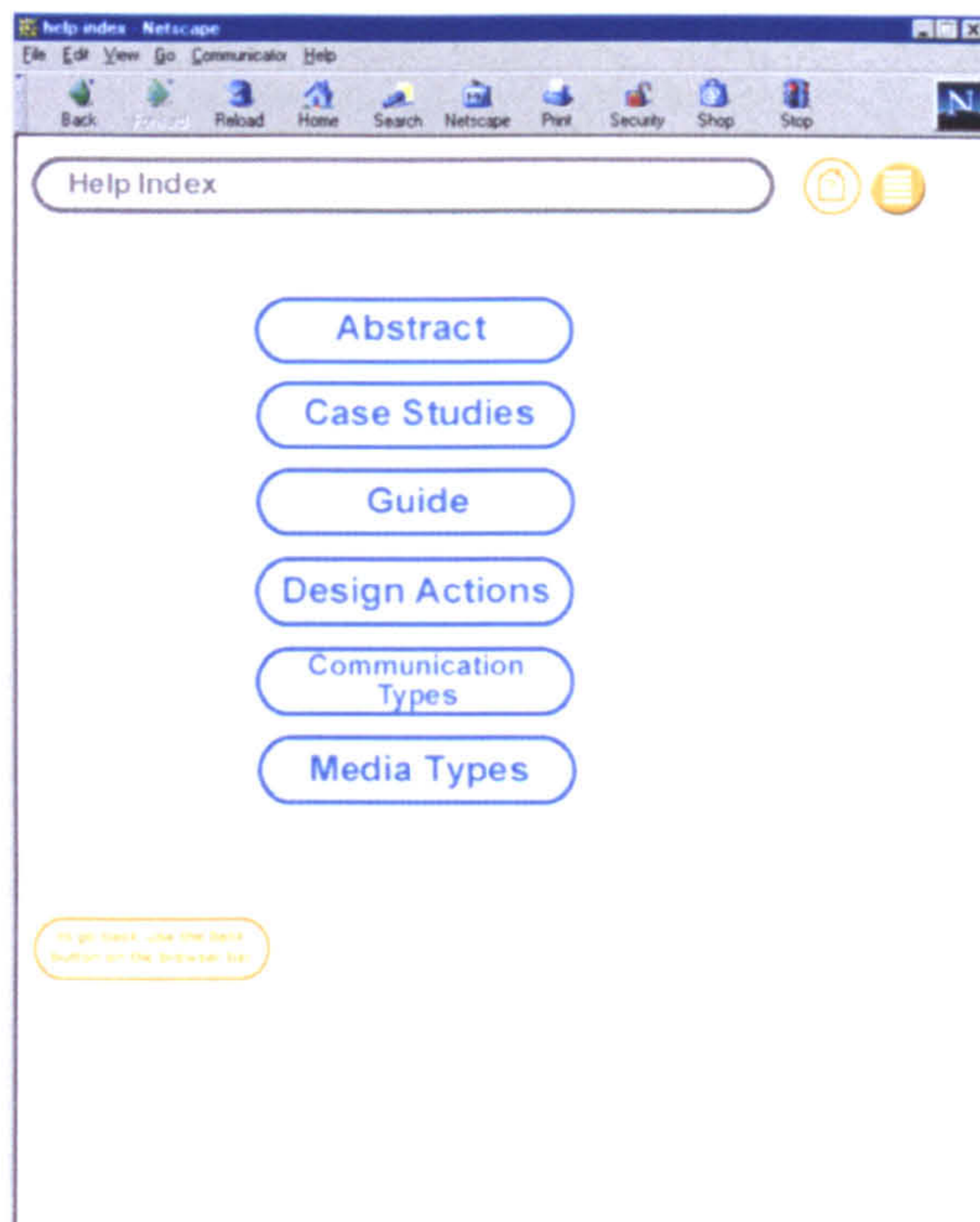

Chapter 1: Introduction

“The greatest difference between the designer and the single independent craftsperson is that the craftsperson does not have the problem of communicating his or her intentions to others for translation into objects. The designer, however, must make his or her intentions explicit – communication is at the heart of industrial design.”

DORMER, P. Design since 1945, Thames & Hudson, 1993, p. 9-10.

1.0 INTRODUCTION

1.1 Introduction

With computers now ubiquitous in the mainstream of everyday life, there is little doubt that information technology is having a real effect on our lives. This is not least the case in industrial design, where computing technology has followed in the wake of advances in engineering and manufacturing. During the past ten years, industrial designers have struggled to come to terms with what these changes mean for both the profession and the everyday working practices of industrial designers. Independent design consultancies have been hit hardest by these changes¹ having to develop new strategies and ways of working with a client and supplier base that have an increasingly technological focus. Often far removed from the strategic debate, designers must learn how to use these new technologies and make them work to best advantage.

An area of significant interest is in the effect that three-dimensional (3D) computing technology is having on the tactical application of the tools and techniques that designers use. This 3D computing technology creates a number of forms of 3D generated digital media that designers use to communicate both internally within their own teams, and externally to clients or suppliers. However, in order to establish the relevance of this 3D digital media, it is necessary to look at all forms of media used by designers within their practice of designing. Therefore, although the focus of interest is on the appropriate use of the *digital media*, which are based on, or derived from, the integration of 3D digital modelling with the design process, the use of all forms of media, both traditional and digital, is considered. This thesis is founded on the premise that effective communication is key to the design process in that it acts as a facilitator for decision-making. Further, that the selection of media will influence the effectiveness of the communication and therefore, that the appropriate selection of media is key to successful decision-making and ultimately a successful design project.

The study is based on a body of work carried out between 1992 and 1996 and is focused on the use of 3D computing as a decision making tool within the design process. The objective is to help designers understand the tactical use of 3D digital media within their everyday working practices. Set against the backdrop of both traditional and digital media, it seeks to establish the means how, the points when, and the reasons why, 3D digital media might be used for communication within the industrial design process. The principal vehicle for answering these questions was through the mapping of case study evidence in the form of an interactive 'heuristic map'ⁱ, presented via CD.

The research has concentrated on reflection on the activities involved in the practice of design, rather than the formulation of theoretical models of its process. Therefore the investigation has focused on practitioner activity. Based on the professional practice of industrial design, through the use of commercial case studies, its findings are aimed at those interested in research through the medium of practice², or the refinement of practice through research, rather than the theory of practice. This is not however, what might be described as a 'studio PhD', it is a serious attempt to bridge the theory/practice divide through the systematic study of professional practice. The practice versus research debate³ is a current 'hot topic' amongst both designers and researchers. This thesis illustrates that although there are key differences between 'practice' and 'research'⁴, there is a method that enables research within the context of fully commercial practice and argues that the findings can contribute to both disciplines.

ⁱ The Heuristic Map is discussed fully in Chapter 5.

This study aims to answer the following research questions:

- *How can industrial designers integrate 3D digital media into their design process?*
- *How can industrial designers use 3D digital media to communicate more effectively within their design process?*
- *When do industrial designers use 3D digital media to communicate within their design process?*
- *Why do industrial designers use 3D digital media to communicate within their design process?*
- *What does this tell us about the impact that 3D digital technologies are having on communication within and therefore the execution of design projects?*

The thesis is divided into six chapters, chapters 1, 2, 3 look at the contextual issues surrounding the research programme. Chapter 1 introduces the background, establishes the research questions, explains the aims and objectives of the programme, and describes the projected outcomes. Chapter 2 describes the context of the study, initially in terms of the historical and technological context, then going on to describe more immediate contextual influences, including a discussion of formative research activities. Chapter 3 outlines the methodological basis, and describes the arguments for the adapted Action Research framework adopted.

Chapter 4 deals with the main body of investigative work, describing the three principal investigative case studies, their analysis and the subsequent construct of the case study data in the form of a heuristic map. Chapter 5 describes the ‘tool for designers’, the heuristic map and how it might be used. Chapter 6 concludes the research findings, defines the routes for further work and reflects on the research programme as a whole. The visual evidence, comprising case study material and the Heuristic Map, represents a fundamental contribution to the research programme. It

is therefore strongly recommended that Chapters 4 & 5 be read in conjunction with viewing the CD.

1.2 The Design Process

Taken literally, the design process can be seen as a course of action or procedure leading to the creation of a plan, purpose or intention, the general arrangement or layout of a product⁵. Within the thesis the use of the term 'design process' refers only to product or industrial design: the design of three dimensional tools or artefacts to suit a purpose.

Within the craft context the acts of designing and making are largely inseparable, whereas within the industrial context, the activities of designing and making are quite separate and usually carried out by different groups of people⁶. Industrial design is mainly set in the industrial context and within it, the design process encapsulates the activities carried out in designing these artefacts. The result of the process is a full description of the artefact to be made, giving enough information that another party might make it. The process is the sequence of activities that occur in its design.

Cross⁷ defines the following stages in the design process:

Clarifying objectives

Establishing functions

Setting requirements

Defining characteristics

Generating alternatives

Evaluating alternatives

Improving details

The design process can be viewed in different ways by different groups: some view it as an essentially internal process, where the design process is seen just as the act of

designing⁸, whereas others⁹ take into account the external influences on the act, including interactions with other parties, such as clients or other information providers.

The thesis studies and discusses the use of 3D digital media within the latter and broader understanding of the ‘design process’. Within the context of this study the design process is taken to mean much more than just the creative act, it includes every element of activity that the designer has involvement with in the development of a product. It takes into account any interaction that the designer has with any party either internally within the design process or externally with a client, suppliers or any other relevant party. It is essentially based on what can be seen as a ‘typical’ design process, encompassing the entire sequence of activities required to get a product to the stage where it can be manufactured.

1.3 The Relevance of CAD

When we describe the use of computing or digital technologies to assist us in the industrial design process we are usually referring to *computer aided design* or *CAD*. But what is ‘CAD’ and why is it important to study its use? In an issue on computer-aided design in 1996, the editors of *Co-Design* attempted a basic definition of CAD:

*“CAD is a computer based system which can receive, hold and manipulate geometric information about an object, and give a visual representation of that object, usually on screen.”*¹⁰

CAD is an acronym of Computer Aided Design and means just that, the process of designing a shape or object directly assisted by the use of a computer. The basic definition of CAD can be divided into two distinct areas, the use of computer aided design tools in the production of either two-dimensional (2D), or three-dimensional (3D), entities. Two dimensional computer aided design (2D CAD) is essentially limited to the electronic replacement of traditional 2D drafting skills, where instead of lines being drawn on paper by hand, they are drawn electronically by a computer, through the inputting of commands by the user. 2D CAD is essentially limited to the

representation of shapes or objects using a computer, the accurate interpretation of which is dependent on the skill of both the creator and the interpreter. Three dimensional computer aided design (3D CAD) differs fundamentally in that the shape of an object is effectively captured within the computer by the creation of a *digital* or *virtual* model. This virtual model contains all the information regarding the shape of the object and therefore enables the accurate communication of that shape. Both 2D and 3D CAD can generate a range of outputs used to communicate the design intent to others, both internally and externally to the process. A fuller discussion of these is made in section 4.5.7.4.

1.3.1 The Concept of CAID

Generally, the terms surrounding the use of computers within industrial design are used loosely, with the true meaning of generic terms such as CAD often lost. The early years of the technology debate saw the term *CAID*, or Computer Aided Industrial Design come into use. Although some companies were quick to suggest that their packages provided the ‘CAID’ solution¹¹, the term essentially describes the application of all forms of computing technologies to the industrial design process. 2D CAID would include the application of illustration or image manipulation software, 3D CAID the application of 3D modelling and visualisation software. McCullagh¹² makes a very concise definition of CAID as:

“the integrated and effective use of computers, by industrial designers, where they aid the design process. CAID software being any software they see fit to use”

He goes on:

“3D CAID therefore describes a particular type of CAID which uses 3D modelling software.”

It can be seen then that the creation of the virtual model is only one part of the package, the term *3D CAID* refers to a whole range of techniques that can be adopted *once a 3D virtual model has been created*. The existence of a 3D CAD model can enable the production of on screen deliverables such as photo-realistic images and

the animations of objects or assemblies. It can also enable the physical manifestation of the virtual model by means of various rapid prototyping techniques such as SLA or SLSⁱⁱ. The definition can therefore be extended to say that:

3D CAID is CAID, which uses as its basis, 3D computer modelling software.

1.3.2 CAID & Digital Media

The effective practice of CAID is inextricably linked to the technologies and media that drive the process forward. These digital media represent the manifestation of an object as it passes through the CAID process. Whether they are in the form of on screen images, a photo-realistic rendering, or a physical model, they provide the means by which decisions about that object are made. Each manifestation of the object serves to provide a means by which the designer can communicate to himself, his peers, his clients, his suppliers or others in order to facilitate the design process. These forms of communication can be seen to have an 'internal' or 'external' status. Internal communication being that focused within the design team, such as a designer communicating to himself or his peers. External communication, that which involves the input of those external to the design team, such as clients or suppliers.

1.4 Why Research?

In the early 90s 'time to market', or the time that it took a new product to reach its market place, was becoming increasingly important. The intensification of international competition combined with contracting product life cycles driving the progressive compression of new product lead times. This saw both the manufacturing and industrial design industries in a state of transition¹³, as the manufacturing companies, who were the clients, invested in new technology and industrial designers were expected to keep up¹⁴. New CAD technologies offered designers a direct link to manufacturing, along with greater flexibility, control and productivity.

ⁱⁱ SLA & SLS: see Glossary

There was initial tentativeness within professional design consultancy practice, where there was concern that what was being sold by the software developers and vendors was expensive hype, not backed up by evidence in the field. However, there was also an understanding that digital technologies and especially 3D computing were part of the future and going to have a profound effect on both consultancy strategy and the way in which designers work. The creation of 3D digital models was such a radical change from traditional design practices of drawing and model making that it was bound to challenge the way in which designers viewed their process. It was also reasonable to assume that the people using the software were not all going to be trained specialists. A 1992 survey¹⁵ found that 78% of industrial designers thought that they should be responsible for 3D CAD as opposed to CAD technicians. The need for this study stemmed from a recognition that the use of 3D CAD represented an enormous intellectual leap from 2D CAD: attitudes, process and methods of working all had to be called into question.

3D hardware and software was significantly more expensive than 2D: this, accompanied by a steep learning curve, made the development of a strategy for the use of 3D digital tools an imperative for every independent design consultancy¹⁶. Developing tactics for the use of that software would become an essential part of that strategy, for most consultancies, this would be an empirical process of trial and error. The Centre for Industrial Design is a research-led design consultancy, which had the experience of using 3D CAD systems in the field earlier than most other design houses. Here it is argued that it is appropriate that this learning experience should be shared with others in order to provide an insight into how these new technologies might best be used. The 3D Digital Model lies at the heart of 3D Digital Modelling Media, this term encompasses all media created directly or indirectly as a result of the creation of a 3D Digital Model.

Among other things, the design process is all about decision making. Deciding which concepts to take forward, what media to use to develop the concepts, what media to

use to communicate the concepts to the client in the form of a presentation. These decisions have always been difficult ones, based a range of factors including availability of resource, skill, the nature of the project and the type of client. As has been discussed earlier in this chapter, 3D Digital Modelling Media is one of the key technologies used within the practice of CAID. This study assumes that the decision to make use of such technologies has already been made, and looks at what decisions we have to make when deciding where or when to use such technologies. In short, we are asking the question: "*what does the designer need to know?*" This study asks questions concerning the use of 3D digital modelling media, involving among others its characteristics, and the advantages and disadvantages of using it at various stages in the design process.

1.5 The Visual Nature of the Project

The programme of study developed around an adapted action research methodology framework (fully discussed in Chapter 3 & 4) focused on the execution of three exemplar projects. These are case studies of live commercial projects carried out within the Centre for Industrial Design. In accordance with case study analysis techniques¹⁷ the case study evidence, including a large number of pictorial references, has been collated and tabulated following a case study protocol defined in Chapter 4.

By its very nature design is a visually oriented discipline. Once the case study approach had been determined and formalised it was deemed appropriate to present the pictorial elements of the thesis in a more interactive format than a traditional bound document. Moreover the thesis focuses on the appropriate use of media in order to communicate effectively, it is therefore imperative that the thesis is communicated, within the limits of PhD regulations, in the most efficient and effective way possible.

In order to contain the visual material, which is the currency of evidence of the case studies, it was decided that a CD would form the most durable and accessible medium. The CD acts as a kind of digital portfolio supporting the written material. It is not intended as a replacement for a book or viewed as a thesis in its own right. Certain aspects of the thesis such as the heuristic map potentially become more accessible to viewers through the utilisation of the interactive capabilities of this digital medium. The complexity of the information presented by the Heuristic Map would be unfeasible in paper form. The Heuristic Map is intended for use by practicing designers and it is believed that designers are more likely to respond to a visual than written medium.

It is highly recommended that this thesis be read in conjunction with the CD as it is only by doing this that the full thesis can be appreciated. Allowances have been made for the fact that the reader will not always have access to the means by which to view the CD, by including images, charts and tables where they are critical to the flow of the text. There are certain sections of the thesis more reliant on the CD than others. Chapter 4 and Chapter 5 in particular, rely heavily on the viewing of the CD to support the written material. This is especially the case in Chapter 5 as this is where the key material and findings of the heuristic map are presented and discussed.

As illustrated in the Preface, the indication for when the CD should be accessed is shown in the text in the form of a CD icon. When the reader sees the icon, they know that the text following will refer in part or in full, to the accompanying CD. The contents list for the CD mirrors the contents list of the thesis, so the relevant CD content can be accessed by merely clicking on the hotlink associated with the paragraph number displayed on the CD contents list.

1.6 Aims & Objectives

The research questions have already been set out at the beginning of the chapter, but in addition to these the study has had a number of aims and objectives, which, along with the methodology, have developed over time. In hindsight, the early aims can be

seen as naïve, and they have developed considerably as the study has progressed, their development reflecting the development of the study as it has progressed. The original aims of the programme were to:

- *Investigate the interface between the industrial designer and a 3D surface modeller, Alias.*
- *Identify possible tactics for the implementation of virtual modelling at strategic points within the design process.*
- *Propose tactics for the utilisation of surface modelling software for the creation of virtual models within the industrial design process.*

During the first stages of the programme, the formative research concentrated on investigating the interface between the designer and 3D surface modelling software, the reasoning was that it was necessary to fully understand the implications of learning such a system prior to making any investigation as to how the software might be used. Following the completion of two formative case studies, some broad conclusions were drawn and a set of tentative statements made with reference to the use of surface modelling software within the design process. This had the objective of validating the conclusions drawn from the formative stages of the investigation by establishing their wider relevance to the researcher's design practice. Following the drawing of these conclusions, the research design was reviewed including the final aim for the study:

- *Propose tactics for the integration of 3D digital media into the industrial design process.*

This had the associated objective:

- *Propose a model for the integration of 3D digital media into the potential development paths through the design process.*

At this point the aim of the study essentially changed from investigating the interface between the designer and the software, to investigating the interface between the design process and 3D computer models *per se*. Although the core methodology remained unchanged, at the time the original aims were devised, the study was focused on a limited software set (surface modelling) and limited to the conceptual stages of the design process. In hindsight, it is apparent that these limitations were principally to do with the resources available and the type of case studies carried out during the initial stages of the investigation.

The development in the aims and objectives of the study over the period can be seen to have direct correlation with the maturing of the Centre for Industrial Design as a research-led industrial design consultancy. The resource base was developing to include both solid and surface modellers as well as supporting 2D applications such as Illustratorⁱⁱⁱ and Photoshop^{iv}. It then further developed towards multimedia, with applications such as Macromedia Director^v and Adobe Premier^{vi}. There was also the development of links with external agencies for the supply of a range of rapid prototyping technologies. Concurrently, the CfID client base was developing so that projects were more in-depth and taken to a greater stage of development.

It had become apparent that software was developing so quickly that it was no longer relevant to study just a single type of software, i.e. surface modelling. In order to provide a balanced study of the field, the use of all 3D digital technologies had to be considered. Further, if it is accepted that the 3D digital model is a basis for 3D digital modelling media, when and where these media were used would have an impact across multiple stages of the design process. It follows that in order to understand the potential integration of 3D digital media into the design process it is necessary to

ⁱⁱⁱ Adobe Illustrator™: see Glossary

^{iv} Adobe Photoshop™: see Glossary

^v Macromedia Director™: see Glossary

^{vi} Adobe Premier™: see Glossary

look at the reasons for using any form of media as a tool to facilitate design activity. The term 'model' was also seen to be inaccurate, the diagrammatical analysis of the case studies would now be presented in the form of a heuristic 'map', with the analogy that a Heuristic Map would be able to guide designers through the complexities of 3D CAID.

1.6.1 The Projected Outcomes

The projected outcomes for the research are:

- *An argument for the case of carrying out 'research through the medium of practice'¹⁸. An explanation of the circumstances of the project, giving a valuable perspective on the area of study. A discussion of the importance of a practitioner's approach through the use of case studies and the value that this programme brings to the study of design and design research, both in theoretical and practical terms.*
- *A diagrammatical representation of the findings of the case studies: the analysis of which enables the creation of a heuristic map. This will illustrate the tactics associated with the decision-making applied by designers in the utilisation of 3D CAID tools.*
- *Conclusions resulting from the cross case analysis of the case studies and their synthesis to the heuristic map. These will relate to the use of 3D digital media as a tool for communication and therefore a facilitator for making design decisions, and the effect that this has on the working practices of the industrial designer.*

¹ RUST, C. Out of the hothouse?, in *Co-Design Journal*, 07.08.09, 1996, p. 16-21.

² ARCHER, B. The nature of research, in *Co-Design Journal*, 01.02.03, 1995, p. 6-13.

³ Design Research Society email discussion list. April 2000.

⁴ DURLING, D. *On Category mistakes*. Design Research Society email discussion list. 26th April 2000.

-
- ⁵ CONCISE OXFORD DICTIONARY 8th Ed. Fowler, H W & Fowler, FG (Eds)., Oxford University Press, 1990.
- ⁶ CROSS, N. *Engineering Design Methods: strategies for product design*, 2nd Ed.. Wiley, Chichester, 1994.
- ⁷ CROSS, N. Ibid.
- ⁸ JONES, J. C. *A method of systematic design*. In: CROSS, N. (ed.), *Developments in Design Methodology*, Wiley, Chichester, 1984.
- ⁹ ARCHER, L. B. *Systematic method for designers*. In: CROSS, N. (ed.), *Developments in design methodology*, Wiley, Chichester, 1984.
- ¹⁰ WALKER, D et al. Editorial Notes, in *Co-Design Journal*. 07.08.09, 1995, p. i-iv.
- ¹¹ CARDACI, K. cited in MCCULLAGH, K. 3D modelling in industrial design, in *Co-Design Journal*, 07.08.09, 1996.
- ¹² MCCULLAGH, K. 3D modelling in industrial design, in *Co-Design Journal*, 07.08.09, 1996, p. 28-35.
- ¹³ MAIER, C. All together now, in *Design*, April 1994, p. 30-33.
- ¹⁴ RUST, C. Op. cit.
- ¹⁵ RUST, C. et. al. *The management of information technology in the professional practice of three dimensional design*, Sheffield Hallam University, 1993. (ISBN 086 339 3748)
- ¹⁶ RUST, C. Out of the hothouse?, in *Co-Design Journal*, 07.08.09, 1996, p. 16-21.
- ¹⁷ YIN, R.K. *Case Study Research: design and methods* 2nd Ed. Sage, 1994.
- ¹⁸ ARCHER, B. Op. cit.

Chapter 2: Project Contextualisation & Formative Research

“The traditional relationship between technology and art has often been instructive, fertile & productive, but the computer goes much further, by challenging many of the boundaries of art and the practice of design. This challenge is part of a broader pattern involving culture, society and technology, and above all brings to the fore the choice that confronts us: either we design our future, or we have it determined for us.”

Robin Baker, Designing the Future, Thames & Hudson, 1993, p. 11.

2.0 PROJECT CONTEXTUALISATION & FORMATIVE RESEARCH

2.1 Introduction

The core investigative period of this research programme falls between 1992 & 1996 and commenced during a period of significant development within the computing and design industry, broadly within the field of digital technologies and specifically within 3D computing. This period of flux led to a significant amount of debate in the industrial design community as to what effect these developments would have on its future. This debate informed and influenced the focus of investigation in this study. During this time there were also a number of key events that had a significant influence. As far as this study is concerned the most important of these was the Product Design and 3D Computer Modelling Conference at Sheffield in 1993. Events at this conference led to the researcher becoming a founder member of CAID discourse, set up to provide a forum for this debate.

The initial section of this chapter looks at external project circumstances and discusses the historical and technological developments leading up to and including the start of the programme. The section on related work looks at relevant studies, both at the commencement of the programme and then throughout the main investigative period. It then goes on to look at the development of design process models in terms of their relevance to the mapping of the design process, as it is understood within this study. The final section on formative research describes how an initial pilot study programme and initial case studies, helped to establish the methodological basis for the main study. This chapter looks at these contextual issues and the impact they have had, on both the execution and outcome of the thesis.

The research commenced at a time when the concepts surrounding the execution of design research were vague; as a design graduate, the importance of a theoretical understanding was not fully understood or implemented. Part of the research learning

process has been a gradual understanding of the importance of theoretical concepts underpinning much of the thinking in design research.

2.2 The Historical & Technological Context

Whilst the last century has seen dramatic changes in manufacturing technologies and production processes, it wasn't until the last decade that the Industrial Design profession saw any significant change from its traditional drawing and model making skills¹. By the late 1980's however, few designers could have been unaware of the digital 'revolution' that was supposedly just around the corner. The technologies of computer aided design and manufacturing (CAD/CAM) promised designers a direct link to manufacturing, offering greater flexibility, control & productivity. Baker² describes the use of computers as moving from the 'desirable' to the 'required' domain and although there were undoubtedly a great deal of exaggerated claims, there was little doubt that digital technologies, and especially 3D digital technologies, were to have a profound effect on the industrial design profession as a whole.

Until the late 80's, the predominant use of CAD and digital visualisation technologies for industrial design remained in the two dimensional domain. 2D CAD was very much used as an alternative to the drawing board, its main advantages that lines drawn there could be edited and the resultant drawing duplicated and stored in an electronic or magnetic medium. The promise of direct access to manufacturing was still characterised by the interpretation of these lines on paper by a model-maker or toolmaker. The accuracy of the final result depended on a combination of the ability of the designer to accurately represent in 2D form, the 3D image that was in their 'minds eye'³, with the skill of the artisan to make a correct interpretation. Industrial design practitioners had also adopted computer software developed for the design for print process. Desk top publishing (DTP), illustration & image/photo manipulation packages were used by industrial designers alongside CAD technology,

to enhance many stages of the process for the creation of presentation materials, 2D renderings and product graphics.

Following the 80's recession, the industrial design industry was in a state of transition, with increasing pressure to get products to market in ever decreasing timescales⁴. Previously, the attention of the 3D computing industry had been focused on the specialist needs of computer animators, or in the large-scale needs of the mechanical engineering industry⁵. Challenges to the profession coincided with 3D CAD vendors aiming their products specifically at the industrial design industry for the first time.

The first 3D CAD system was developed in the early 60's, with the academic research in the late 60's and early 70's of Dave Evans and Ivan Sutherland among others, driving that development into commercially available systems⁶. By the early 1990's, 3D CAD systems were in regular use by industrial design consultancies⁷. Along with the arrival of 3D CAD came the development of new technologies and media to enable what was termed: 'rapid prototyping'⁸. These technologies offered part of a solution to the time pressures faced by the industrial design profession and rapidly became part of the accepted tool-set⁹. Rapid prototyping is the generic term given to a variety of different processes including multi-axis machiningⁱ and stereo-lithographyⁱⁱ, which can be used to create a physical model from a 3D data model, accurately, and usually in a much shorter time than by traditional model-making methods. Each individual process has a different set of characteristics and therefore tends to be used for different applications. They all have a core set of benefits to the industrial designer and the industrial design process in that they provide;

- *an accurate physical representation of the 3D virtual model,*
- *a physical model in less time than by traditional methods,*

ⁱ Multi-axis machining: see Glossary

ⁱⁱ Stereo-Lithography: see Glossary

- *clarification of functionality, fit & form,*
- *absolute physical confirmation of design intent, and*
- *a powerful communication & selling medium.*

Rapid prototypes could be employed for a number of different uses, enabling the creation of prototype models, appearance models, low volume production and casting patterns, thus providing the physical 3D confirmation of the 3D virtual model, necessary in order to make well informed design decisions.

2.2.1 Digital Technologies & Manufacturing

3D CAD has also had a profound effect on manufacturing, providing a core technology within the interchangeable concepts of ‘Concurrent’ or ‘Simultaneous’ Engineering¹⁰. Originally defined by the U.S. Institute of Defence, Concurrent Engineering (CE) is essentially a process for managing product development in order to reduce costs, improve product lead-times and improve product quality¹¹. Mortimer & Hartley¹² define CE as:

“an integrated approach to new product introduction. Using multi-function teams or task forces, it ensures that research, design, development, purchasing and supply and marketing all work in parallel from concept through to the final launch of the product in the market place.”

CE essentially means that all the different departments involved in a project work on the project concurrently rather than sequentially, i.e. a 3D CAD database can be worked on, viewed or interrogated by a number of teams simultaneously, whether in the same building, or across continents. One of the better known examples of this is within the Ford Motor Company, where design teams, engineers and global suppliers can ‘share the geometry’ of a vehicle across common software platforms¹³.

The belief at the time was that 3D CAD was going to make things ‘faster-cheaper-better’¹⁴. *Faster* – because all parties were working on the same thing at the same

time. *Cheaper* – because unnecessary parts of the process were cut out. *Better* - because it enables ‘Right First Time Design’, moving the design straight from CAD package to manufacturing, thus removing the constant doubt that so characterised traditional manufacturing processes; that what would come out of the tool would be as the designer had originally intended. Consequently, 3D CAD was generally viewed as a panacea for the design process.

Companies like Black & Decker¹⁵, realising the need for a ‘culture shift’ towards CE, saw that 3D CAD was at the hub of this change. They saw that this would have major impact on the way that their designers worked. However, they warned that Concurrent Engineering is more than just Parallel Engineering: if stages are not frozen, lead times can be as long as with traditional methods as the temptation is always to make constant revisions.

With these new demands for close working relationships, independent product design consultancies were seen to be on the back foot. A survey carried out in 1992¹⁶ found that manufacturing industry was much more pro-active towards new technology than independent consultancies. It went on to suggest that the real future for interactive 3D working was within in-house teams, with more financial support, better communication links and greater cross-disciplinary opportunities for the industrial designer.

2.2.2 Digital Technologies & Industrial Design Consultancy Practice

Whilst manufacturing industry was embracing these new technologies with open arms, interviews by research colleagues found the Design Industry a little more cautious¹⁷. The financial implications for a small company investing in CAD were and still are quite significant. As with any new technology the cost of investment was significant not only in terms of hardware but also in software and training. In the early 1990s the predominant hardware within product design consultancies were PCs and Macintoshes, with only 7% of product design consultancies, as opposed to 62%

of manufacturing companies, investing in the sophisticated workstations that were at the time necessary to run 3D CAD systems effectively¹⁸.

As the manufacturing companies who predominate the client base invested in new technology, product designers were expected to keep up. Even if the decision to make the investment were taken, an even more significant problem would arise, in the question of which software system to employ¹⁹. Historically designers and engineers have had differing sets of requirements for 3D modelling, as they have different requirements in terms of both what they want them to do and how they want to use them²⁰. At the start of this project there were two main types of modellers on the market: solid and surface modellers, each with their own distinct set of characteristics.

Surface modellers have their roots in the automotive industries and animation, where the flexibility of the modelling architecture was appropriate to flexible operation and shape definition requirements. Solid modellers on the other hand, with their inherent accuracy and capability for finite element analysis (FEA), thermal modelling and mould flow etc. have been traditionally used for engineering and manufacturing²¹.

Surface modellers

Surface modellers work by creating just that, surfaces. These surfaces have no effective thickness and can be shaped and joined together, or joined to others to create almost any sort of physical 3D form in space. The interaction tends to be flexible, with the user able to push and pull the shape until it is just the way he or she wants it. Surface modellers are generally better for the creation of freeform shapes than engineering detail.

Solid modellers

Solid modelling is typically more like creating something in a workshop. The user starts with a block and carves it, machines it and fillets it until it becomes the shape he or she wants. Solid modellers tend to have parametric databases, in that each

feature is historically linked to the model, the user can therefore go back and change the size of a fillet for example, this change would then be updated in all relevant parts of the model. Because of this and their tendency toward Euclidean forms, solid modellers tend to be more useful for creating engineering designs that rely on geometric accuracy.

Surface modellers were generally better for creating the freeform shapes that designers wanted to achieve, and many could be run on PCs or Macintoshes. Workstation only packages such as Aliasⁱⁱⁱ offered the option of creating photo realistic visualisations and animations using the 3D model as a basis. On the other hand, solid modellers have much better access to the features required by engineering and manufacturing such as multi axis machining, rapid prototyping, tolerance and interference checking, 2D drafting and FEA²². In addition to the choice of modellers was the problem of translating data between different CAD systems, CAD vendors were full of the hyperbole of 'seamless data transfer': finding out whether translation between systems was an option tended to be a process of trial and error.

Rust²³ argues that 3D CAD is not an optional extra for design consultancies. He reasons that with manufacturing techniques moving towards the use of a core 3D CAD model, only consultancies that can supply data in this way may be considered. He goes on to suggest a hypothetical future model for consultancy where they are seen as either strategic influencers or multi-disciplinary one-stop shops. Whether or not this will prove the case has yet to be seen, although there has been some settling out of practices where 3D CAD is essentially now the norm, with most consultancies having some 3D digital modelling capability. Such companies include those in the researchers's own experience: Random & Alloy, as well as companies such as Therefore or PDD^{iv}.

ⁱⁱⁱ Alias™: see Glossary

^{iv} Therefore & PDD: two design consultancies based in London, both of whom use engineering based 3D CAD software.

Although there was undoubtedly a tentativeness toward 3D CAD within consultancy practice due to concern over investment commitment and software selection risk, there was also an understanding that new CAD based technologies were going to have a profound effect on both consultancy strategy and the way in which designers work. By the mid 1990s many consultancies had embraced the use of 3D computing and were starting to define their own methods for using the tools^{24 25}.

2.2.3 Digital Technologies & Design Research

Around the time that these technological events were impacting the consciousness of the manufacturing & design industries, a number of design schools, polytechnics and universities had set up design research units, e.g. The Centre for Industrial Design (CfID) at the University of Northumbria (UNN), The Visual and Information Design Research Centre (VIDe) at Coventry, The Design Research Centre (DRC) at the University of Derby and The Design Engineering Research Centre (DERC) at the University of Wales Institute at Cardiff. With the introduction of the 'new' Universities it had become increasingly important to gain a research standing and therefore funding. This saw an increase in design research activity but relative to the more established disciplines such as science, the field of research studying the impact of technology on industrial design practice was still fairly new.

Many of these new research units sought to respond to the changes within the technological market place to see what this meant to the field of design. Traditional methodologies were starting to be challenged and design was proposed as a cross-disciplinary subject in its own right²⁶. A series of conferences managed by these Universities between 1992 and 1996 (following) highlighted the fact that the introduction of such technologies was resulting in a significant amount of debate within the UK.

One of the most important to this study was the 'Product Design and 3D computer modelling' conference held at Sheffield City Polytechnic in 1992²⁷. The aim of this conference was to open up the debate on the use of CAD by product designers. The

keynote paper²⁸ covered a valuable study carried out at Sheffield which established a broad understanding of the penetration and understanding of the use of CAD within the UK industrial design industry as a whole. Coinciding with the commencement of this study, this conference was highly influential on the direction of the study and prompted the founding of CAID Discourse.

Again in '92, a symposium organised by Coventry University: 'Virtual representations for design and manufacture'²⁹ tried to define the true meaning of VR, or 'virtual representation' and explored its potential impact on design and manufacturing. Again, this conference was influential in that it started to explore issues close to the focus of this study in terms of the use of visual tools as communication and development tools for the industrial design process.

One of the more active research groups at the Birmingham Institute of Art & Design held a conference entitled 'Information technology & design: new perspectives', hosted by the University of Central England in 1993³⁰. The conference, which explored the effect that computers were having on the integration of designers with design and manufacturing systems, yielded some work specifically relevant to the study (discussed in 2.4.2).

These and the conference: 'Computer aided industrial design – reflections & insights', held at the University of Northumbria in 1993³¹, which explored the general concept of CAID; influenced the early thinking in the study. Other conferences were more influential in a general sense, helping to establish the relevance and importance of the subject area, also enabling the researcher to keep up with the general mood and direction of the research community. These conferences included: 'Design of the times' at Staffordshire University in 1994³², which attempted to bring design research and design practice closer through the exploration of new responsibilities, methods and directions. 'The role of product design in post-industrial society' at the Kent Institute of Art & Design in 1995, investigated the role of design in the age of computers and technology. Exciting new dimensions for art &

design were explored at '4D dynamics: an international interdisciplinary conference on design and research methodologies for dynamic form' at De Montfort University in 1995³³. This conference explored the fourth dimension in design and engineering, that of time. The work of another research group at the University of Derby was expressed at 'CAD, colour & communication' in 1996³⁴, a bi-strand conference exploring the effect of computing on colour & communication.

Another influential conference, repeated bi-annually, is the 'CADE' series of conferences, which look at the development of computers in art and design education. Although not directly relevant to the study, these conferences³⁵ were important in that they looked at the effect that the introduction of computers were having in art & design education, as well as exploring the research aspects in terms of both methodologies and specific research projects.

It is believed that there are two main reasons for the quantity of conferences in the UK around this period (92-96). The first is that some of the research centres were set up in direct response to the conversion of the old polytechnics to become 'new' Universities, and the accompanying potential to obtain research funding. The second and more likely reason relates to the premise of this thesis, that the rise in the availability and use of advanced digital technologies for design would raise significant questions as to its use. The quantity of conferences is testament to the fact that the issue of computing, its development and impact was and remains, an issue of serious concern to both research and practice. At this time the focus of the debate was still predominantly academic, although it was becoming clear that due to the fact that practitioners were coming under increasing pressure to use the technology, the subject area was going to require more involvement by, and study of, practice. This thesis argues that these issues were so fundamental to practice, that the study of the practical issues relating to the use of digital technologies within design was essential. However, when this research programme commenced there was still little evidence of true learning and development through practice-based research as described by the action research methodologies of the education tradition³⁶.

2.3 Models of the Design Process

There are many models of the design process, the following section summarises a cross section in order to establish their relevance to the investigation. Modelling the design process is an attempt to understand the intuitive nature of the process by explaining it and making it explicit. Some have tried to describe the design process, others to prescribe how it should be carried out. Later and more exciting developments have tried to reflect how it is actually done by holding a mirror up to practice.

2.3.1 History

The process of designing is not new; all civilisations have applied the process to the creation of artefacts³⁷. In craft societies the processes of designing and making were pretty much combined, in modern industrial societies however, the process of designing is usually separate to that of making³⁸. In modern terms we can see the ‘design’ process as quite separate from the ‘making’ process, which in industrial design terms usually refers to mass manufacture.

Attempts at making sense of the design process have been going on for a long time. Early ‘rationalist’ approaches to design can be found in Germany through the work of Peter Behrens at AEG, the Deutscher Werkbund and the Bauhaus³⁹. The roots of a modern ‘scientific’ approach to design can be found in the consumer boom following the Second World War, when designers were having to justify that design had more to offer than just superficial aesthetic treatments⁴⁰. The German post war design school: Hochschule fur Gestaltung at Ulm, defined design methodologies which sought to establish standard working methods for designers, finding a recipient for its ideas at the household appliances manufacturer, Braun. Germany still strives for a rational approach; the professional engineering body; Verein Deutscher Ingenieure, state in part of their guidelines; ‘Systematic Approach to the Design of Technical Systems and Products’, that:

“The design process, as part of product creation, is subdivided into general working stages, making the design approach transparent, rational and independent of a specific branch of industry”⁴¹.

In the UK, other designers were active in the attempt to define a ‘scientific’ approach to designing. In 1961, Bruce Archer, having been active in proposing a ‘scientific’ approach to design was appointed to run a design research unit at the Royal College of Art, which developed to become a Department of Research in 1972. Scientific design procedures were also being developed in the USA where, in 1955, Walter Dorwin Teague and Frank de Giudice used a programme of analysis and empirical testing to design the interior of the Boeing 707⁴². In Holland, the appointment of architect Rein Veersema to Philips saw its design strategy becoming much more structured, illustrated by the ‘Philips design track’⁴³, a linear model of design for problem solving.

2.3.2 Prescriptive Models

Models of the design process tend to be either descriptive or prescriptive. Descriptive models describe the sequence of activities that typically occur within the design process. Prescriptive models suggest an improved or more effective pattern of activities.

Prescriptive models can be characterised by the work done by Archer⁴⁴ and further by Jones⁴⁵, the focus of many prescriptive models being on the identification and understanding of the design problem. Analysis of the problem enables the definition of performance specifications, and the generation of alternative designs builds up a series of sub-solutions to the problem. The solution is to be found in the rational choice of best alternative designs. Jones suggests a simple systematic method of:

Analysis – Synthesis – Evaluation

A more detailed prescriptive model is suggested by Archer in which he identifies six types of activity that include various inputs and outputs including interactions with the outside world. These six types of activity;

Programming - Data collection – Analysis – Synthesis – Development - Communication

Can be summarised into three phases;

Analytical – Creative - Executive

Archer described this process as a kind of ‘creative sandwich’; starting the process with observation and inductive reasoning; before moving on the ‘creative’ phase involving evaluation, judgement, deductive reasoning and decision making; and finally leading on to the description and communication of the final design.

Although at first sight these models appear quite sensible, they are focused on a completely rational set of procedures, where the designer would not move on to a new stage until the previous one was complete. Although the implementation of most of these models would involve iterative phases, it is unlikely that in practice, these models would be rigorously adhered to. Hickling⁴⁶ argues that the unnatural rigour of such processes may lead to failure and feelings of guilt.

2.3.3 Descriptive Models

Unlike prescriptive models, which are process focused, descriptive models tend to be solution focused, conjecture is followed by analysis, evaluation, refinement & development. Cross⁴⁷ defines a simple descriptive process based on the ‘essential activities’ of the designer as:

Exploration - Generation - Evaluation - Communication

French defines a descriptive flow chart type model as being based on the following set of activities⁴⁸:

Analysis of Problem - Conceptual Design - Embodiment of Schemes - Detailing

Many descriptive models become quickly obscured by detail as each activity is investigated in detail, however the model by Pahl & Beitz⁴⁹ offers a clear interpretation of the design process:

Clarification of the task - Conceptual design - Embodiment design - Detail design

These headings summarise a number of detailed stages:

Task – Specification – Concept - Preliminary layout - Definitive layout – Documentation - Solution

Despite their various differences, all of these models cover the same essential phases in the process, first of all some form of problem identification, then some form of generative phase, then some form of presentation enabling choice, and finally a phase in which a solution is defined. As the iterative nature of the design process has become more accepted, descriptive models have developed an advanced form in the ‘cyclic’ model.

2.3.3.1. Cyclic Models

Cyclic design models are a development of descriptive models and take the cyclical iterations that exist within each stage of a more linear descriptive process one step further. The cyclic model is solution focused and recognises that designers need to explore and develop the problem and solution at the same time. Lateral thinking and creative insights usually coincide with skips and flashes of inspiration, often missing out the more accepted parts of the process⁵⁰. Cyclic processes encourage learning⁵¹ and accept that mistakes will be made.

Although still representing a ‘rational’ approach, a version of the cyclic model is suggested by March⁵². He introduces another element to the conventionally understood forms of inductive and deductive reasoning adding a ‘productive’ form of reasoning, hypothesising what *may be*, to create a model for a design process based on:

Production – Deduction – Induction

Although there is undoubtedly a logical progression from problem to sub-problem & from sub-problem to solution, there is a concurrency and symmetry suggested between many events that is not apparent in the more linear models.

A much more radical approach is taken by Hickling⁵³ in his description of a potential model for design. He suggests that many forms of professional practice as well as design, including; medicine, town planning and business management have adopted a linear process based on the scientific rationale of:

Observation – Interpretation - Theory

He argues that all these processes can be seen as decision making processes – whether related to medical treatment or the configuration of products, that design models should mirror practice, rather than describing or prescribing for practice. He suggests that such models might provide a more useful basis for design process than the antiquated perspective of the scientific method, and linear inductive and/or deductive sequence.

Believing that it is impossible to impose the linear model on a creative process such as design, he proposes a cyclic ‘whirling’ process as a generic model of decision-making based on the following activities:

Shaping – Generation – Comparison - Choice

Within his cyclic ‘whirling’ model, recycling and skipping become the essence of the process. If the designer reaches a block, they can move on to a different part of the process, with no implication of a correct method of proceeding. He then goes on to propose an extended cyclical ‘whirling’ process where each of the activities is a decision making process in its own right.

2.3.4 New Product Development Models

Some models of the design process incorporate aspects of the development process extending beyond the immediate remit of the industrial designer. These models describe the phases of activity required to bring new products to market. These new product development (NPD) models are presented with varying degrees of detail.

Bruce⁵⁴ defines the NPD process as the falling into three stages:

- *Phase 1: Planning*
- *Phase 2: Design and Development*
- *Phase 3: Manufacture & Sales*

The British Standard Institution⁵⁵ identifies a chronological sequence comprising four stages:

- *Stage 1: Conceptual Design*
- *Stage 2: Embodiment Design*
- *Stage 3: Detail Design*
- *Stage 4: Design for Manufacture*

Moore and Pessemier suggest a more comprehensive NPD process based on seven steps:

- *Step 1: New Product Strategy*
- *Step 2: Idea Search*
- *Step 3: Screening*
- *Step 4: Business Analysis*
- *Step 5: Product & Process Development*
- *Step 6: Product Testing and Test Marketing*
- *Step 7: Introduction*

What is interesting about all these models is that they are chronologically focused and whilst there is undoubtedly a chronological aspect to any product development process, they appear idealised, not taking into account any of the iterative elements that are bound to exist in a product development process.

2.3.5 The Relevance of Design Process Models

Some of the models described here view the design process as just the 'act' of designing, with little accommodation for the various external factors affecting the process. Others, such as the NPD models described later in this section encompass parts of the process that the designer is less likely to have significant involvement in.

Cyclic processes, such as that proposed by Hickling⁵⁶, would seem to be an accurate reflection of practice but to the researcher, do not appear to take into account the commercially enforced linearity of the process. The tendency is for clients to pay for blocks of design; these 'blocks' are more likely to conform to the type of design process stages suggested by French⁵⁷.

When the term, 'design process' is used within the context of this thesis, it refers to all the activities carried out by the designer in the execution of a project to satisfy the commercial requirements of that project. This would typically encompass a range of activities from brief definition through to final specification of the product for manufacture, and potentially further to include activities such as pre-production liaison.

2.4 Related Work

The study discussed in this thesis relates broadly to much of the work conducted within many of the design research units described in the section on digital technologies and design research. When this research programme started there had been very little research into the field of industrial design and digital technologies, even less had been published. Many of the projects described in the following section were in their formative stages at the time the study commenced.

There has been significant work done in the related fields of engineering and architecture, specifically in terms of the work done by Purcell^{58 59}, Maver^{60 61} and Lawson⁶². However, during the period of this study there has been less research done, in terms of the practical application of digital technologies and specifically 3D CAD, to the *industrial design process*. This has been partially counteracted by the work of Tovey^{63 64}, which, although focused on automotive design, crosses engineering and industrial design boundaries. The work being carried out by research centres all over the country had a great deal of validity, however, the lack of research on design practice in the wholly *commercial* context, would suggest that there was much less of what Archer describes as '*research through the medium of practice*'⁶⁵.

2.4.1 Broad relevance

Some of the more broadly relevant work to date has been focused on the general impact of technology on the design industry and the design process. This includes the work carried out at Sheffield Hallam University (then Sheffield City Polytechnic)⁶⁶, which comprised a valuable survey of CAD use within the industrial design and manufacturing industries. This provided an early insight into the status of the technology within the industry as well as providing clues as to how the industry might develop as a result. The key proposition was that the industrial designer would develop their CAD and concurrent engineering skills more in an in-house, than consultancy environment. Further, Rust suggested a series of models for how design consultancies might form themselves to cope with the changes that the introduction of CAD would bring⁶⁷.

The early work on the programme described by this thesis represents one strand of a bi-strand study carried out within the CfID on the impact of 3D CAD on designers and design practice. The focus of this study is essentially on the tactical implications of its use, whereas, the focus of investigation for another researcher within CfID, was in terms of the strategic use of 3D CAD within industrial design consultancy practice. Unfortunately this programme remains uncompleted, but the work still stands through published papers⁶⁸ as a benchmark to early thinking in the Centre at

that time and has subsequently influenced teaching material concerned with contemporary influences on design practice at the University of Northumbria at Newcastle⁶⁹.

Engineering research into the use of CAD is prolific and wide ranging⁷⁰. Much of the work in this area focuses on investigation into the assessment or creation of verification and optimisation tools, as well as looking into the automatic selection of the 'best' design route⁷¹. Whilst this work is interesting, its focus is very much on convergent, rather than divergent thinking⁷², looking to establish a single optimum route, rather than a number of rather more subjective options. This is quite contrary to this study, where the objective is to establish a range of solution facilitators, and to provide tools to make an informed choice depending on circumstance and context.

2.4.2 Specific relevance

Researchers from Coventry University carried out probably some of the most related work to that of this thesis. The projects which were most related were part of a design research programme: CAVS (computer aided vehicle styling) & CACD (computer aided concept design). The researcher became familiar with this programme over a period spanning 1992 to 1995 through a series of papers and conference proceedings^{73 74 75 76 77}. One of the researchers on the programme was investigating a PhD programme entitled: *'Computers as an aid to decision making in the Industrial Design Process'*, investigating the use of a CAD system in the conceptual stage of a vehicle styling project. He saw the primary objective as defining an agreed design process before investigating what computer aided tools could be applied to it, then seeking to apply these findings to general product styling. A series of CAD tools were then applied to each of the defined stages in the vehicle styling process. There were certain key similarities making his work relevant to this thesis:

- *The use of a design process to use as a time line by which to guide the application of technologies*

- *The practical application of the work- the research was looking specifically at how the designer interacts with the CAD system and is intended for use by designers*
- *The definition of key Management Intervention Points, which define when and what specific media can be used in order to facilitate the decision making process.*

There were also key areas in which the research was distinctly different:

- *The research investigation was based on the process for vehicle styling, rather than industrial design in general*
- *The design process used was focused merely on the conceptual, styling stages of the design process, rather than the whole design process.*
- *The research was looking at designing bespoke tools for use, rather than establishing what tools would be best to use within a range of options.*

Also relevant to this programme, an outline for a PhD investigation presented in a paper by Suntharalingham⁷⁸, the aim of which was to, “*assess and propose methods to support the design process*”. At the time of the paper the work was focused on the relationship of Alias (one of the pieces of test software for this thesis) to the industrial design process. A model of the design process is defined based on four core areas: Analysis, Synthesis, Evaluation & Validation. All the stages in the process are studied and the areas where Alias might aid the design process are identified. Stressing the importance of careful consideration of when to use Alias in the process, the author describes the potential for the use of Alias primarily in the synthesis stage where Alias gives “*the designer the ability to visualise and communicate his ideas without any ambiguity*”. He then goes on to describe how the digital model can be utilised throughout the other stages of the process for outputs such as appearance models, photo-realistic visuals or animations.

Although the paper cites no specific evidence, the supposition that a final appearance model might be the conclusion to the project, suggests that the author may perceive the 'design process' to be limited to the conceptual, styling stages and therefore that many of the potential practical and technical difficulties have been overlooked. However, it does provide a useful benchmark as to how other 'designers' might see the use of software such as Alias in a specific way within the industrial design process.

Both the Coventry and Birmingham projects have similarities to this study in that they characterise the design process, then apply characteristics in the form of a technological approach to that process. The similarities evident between these projects and this study help support the idea that the subject area is topical and worth investigating.

There has been a considerable amount of research into the use of sketching^{79 80} and the use of visualisation in the design process. There has also been investigation into the use of CAD and the capturing of imprecise data⁸¹, as well as into definitions and understandings of the creative process⁸². However, many studies appear to be concerned with only the conceptual stages of the design process, where the creative processes are intuitive and thinking divergent⁸³.

Other work not relevant to the investigative stage of the study, but relevant to the philosophy and presentation of the thesis are PhD theses recently completed by Pedgley⁸⁴ and Bunnel⁸⁵. Pedgley's thesis is relevant in that it has a strong practice element whilst maintaining the methodological rigour required of a PhD study. It is also relevant in that he has decided to disseminate the results more widely via use of the Internet. Bunnel's work is relevant for the fact that not only is the thesis presented entirely in CD format, but the research was practice-based, with the argument that the CD is representative of the practice focused philosophy of the research programme. However, it is reported to have a number of problems including

navigational difficulties and a lack of narrative thread, suggesting that presentation by these means has a long way to go. Durling comments that:

*Its real value is perhaps as a benchmark for how much more work needs to be done to achieve a successor to the conventional thesis.*⁸⁶

2.4.3 Practical relevance

On a practical level several commercial design groups have considered the use of computer aided design tools. Although it is notoriously difficult to find time for reflection in action within design practice, groups such as PSD⁸⁷, PDD⁸⁸ & Black & Decker⁸⁹, as well as in the researcher's own practice at Random & Alloy, have all found the time to reflect on the effect of digital technologies on their working practices, albeit not in a formal research environment. It is essential that this practical evidence be fed into the academic knowledge base, this research programme moves forward in having done this through the use of case studies of practice.

Work that is practice-based contributes most strongly to the subject matter of this thesis. From a practitioners point of view the need to research is understood but personal experience suggests that the oblique nature of much academic design research presents a barrier to dissemination, to many designers the language may seem impenetrable and the relevance to their practice unclear. This thesis has therefore drawn mainly from the fields of study found to have both practical as well as theoretical applications.

2.5 Design Practice V Design Research - The relative value of this project

*"For some practitioners, design research will always be an unwanted bastard"*⁹⁰

2.5.1 What it means to be a design practitioner in design practice

Design practice by its very nature is aggressive, passionate, fast, traumatic and subject to change at a moments notice. As well as sustaining the demand for creativity and innovation, design practitioners have to be able to manage clients as

well as constantly keeping up with design trends, new processes and technologies. On one hand, design practitioners are reactive, often expected to respond to clients' demands at very short notice. Despite a few notable entrepreneurs such as Dyson⁹¹, in the main it is still very much a service oriented industry. On the other hand, design practitioners have to be proactive, to pave the way for the development of new and improved goods, products and services. They have a responsibility to their clients to investigate and improve product aspects such as manufacturing efficiency, product effectiveness and brand awareness. They have a responsibility to the end-user to investigate and improve product experiences, product quality, ease of use, aesthetics and environmental impact. Finally, they have a responsibility to their own profession to investigate and improve the process by which they do things in terms of both human and technological resources. In practice each designer or design team has a tacit knowledge of his or her design process, only rarely is it formalised. It is imperative that these processes are studied and made explicit in order that we might understand what we are doing and why we are doing it, and how we might improve it and promote it's value amongst other disciplines.

2.5.2 What it means to be a design researcher in design research

Archer describes research as "*systematic enquiry whose goal is communicable knowledge*"⁹². Design research is the methodical study into a certain area of the subject in order to more fully understand the processes at work within that area. The study must result in knowledge in order to further inform the subject. Design research is a subject still very much in its infancy⁹³ and design research is still trying to find its feet in terms of an appropriate methodological approach, to either adopt or define. However, design research is dogged by similar problems of definition affecting its core subject - design. Design is cross-disciplinary⁹⁴, making it difficult to fully define what 'design' is and what a 'designer' actually does. Design researchers try to carry out effective design research with the tools and techniques that they have at their disposal, primarily those borrowed from other disciplines and subject areas. Most design research is carried out within academic institutions, many of which have strong links with external companies, but by their very nature must

preserve the uniqueness of the learning environment. Many design research projects are not practice-based, even fewer are based on the study of the commercial design process, many focus on an abstracted investigation of the design process, with the researcher on the outside looking in. This develops a theoretical understanding of the subject as a whole, but due to a general perception that research is not immediately relevant to practice, is unlikely to filter through to the designer 'on the shop floor'.

2.5.3 The conflict between design practice & design research

Design research has to be methodical and methodological, it involves literary review and requires an understanding of design epistemology. The terminology in itself is alien to the majority of design practitioners. In carrying out this study, it has been found that the experience of carrying out design research within both the academic and commercial environments is extremely difficult, but invaluable to the development of research that informs practice. As has been shown by recent debate, there is still a significant gap of understanding between the theory and practice of design, hence, design practitioners may find it difficult to see the relevance of the more theoretical findings of design research and, in turn, design research may tend towards theoretical generalisations about practice which are more philosophical than practical.

This study was conducted on the premise that when carrying out research through the medium of practice, it is vital that the research framework supports, but does not restrict, the ebb and flow of the commercial design project. Therefore, in order that the research activity did not conflict with the natural execution of the design project, within this programme, phases of design activity were conducted in an uninterrupted manner. Reflection and research activity occurred in cycles after events during the design process, using material gathered over the course of the project. At present, the study of commercial design projects is very poorly represented within design research. It is believed that the development of research frameworks and methods appropriate to the study of commercially driven design is critical to the furthering of a subject that should be supported by the intellectual rigour of its research base. It is

suggested that the intellectual development of design practice has much to learn from other vocational and practical professions that utilise the results of research to develop practice. For example, the educational tradition in the application of action research through a process of reflective practice that constantly strives to improve practice⁹⁵ or from the medical tradition, applied research which thrives on the publication and dissemination of good practice⁹⁶.

2.6 Formative Research

This section summarises the initial phases of the research study. This commenced with a pilot study programme, which provided essential familiarisation with the subject matter. This was followed by a software familiarisation exercise and the execution of two trial case studies. The findings from these generated a set of tentative positional statements and contributed to the methodological approach being formulated for the full investigative phase of the research programme.

2.6.1 Pilot Study

Part of the early research comprised a pilot study designed to provide essential familiarisation with the subject area of 3D computing. At the time, the knowledge of the subject matter of the research was minimal and there was no body of knowledge in existence to give an objective overview. Prior to the commencement of the study, CfID had purchased a state of the art 3D surface modeller 'Alias'. With roots in the automotive and film industries,⁹⁷ Alias was promoted as a product design tool. Part of the early focus of investigation was on the place that this modeller would have in the study. From discussion of the differences between surface and solid modelling in 2.2.2 it can be seen that a surface modeller can comprise only part of the picture. It was therefore deemed necessary to source an alternative solid modeller to contrast with the modeller already purchased.

The pilot study had two key objectives; first, familiarisation with the subject area and the technology in order to provide an adequate base on which to build the full

research programme and second; research a complimentary 3D modelling system to the one which was already in place.

2.6.1.1. Subject Familiarisation

This involved a period of general familiarisation with the current status of 3D CAD through the following:

- A literature review focused primarily on periodicals. The subject area was so new that there were few specific books written on the subject.
- Attendance at two key conferences: “*Product Design & 3D Computer Modelling*” at Sheffield City Polytechnic (now Sheffield Hallam University), and “*Virtual Representations for Design and Manufacture*”, hosted by Coventry University.
- The establishment of the CAID (UK) Research Group. We set up this research group (no longer in existence) in conjunction with other researchers who had a similar interest in the subject. The group was set up in response to the lack of a body of knowledge and it was intended as a vehicle for information sharing, the publication of research material and as a focus for CAID research.

2.6.1.2. Which Solid Modeller?

Following the attendance of research colleagues within the Centre at a conference on Rapid Prototyping^v, the importance of solid modelling within the 3D scenario became apparent. Solid modellers were important not only in representing a different approach to 3D modelling, but they provided a direct link to tool-making and tangible 3D outputs such as Stereo Lithographic models (SLA^{vi}) and Computer Numerically Controlled (CNC^{vii}) machining. Following a visit to CAD/CAM '92 (a computer aided design and manufacturing conference held at the National Exhibition

^v Rapid Prototyping: see Glossary

^{vi} SLA: see Glossary

^{vii} CNC: see Glossary

Centre) and demonstrations from software vendors the following systems were reviewed:

- I-Design^{viii}, I-DEAS^{ix}, CDRS^x, Pro/Engineer^{xi}, Euclid^{xii} & 3Dgo^{xiii}.

As a result two systems were short-listed:

- Parametric - Pro/Engineer,
- Matra Datavision – Euclid.

There was concern that Euclid had shortcomings in terms of user friendliness and software expansion: following tests, problems of its compatibility with Alias were also found. Conversely, Pro/Engineer had the following advantages:

- Compatible with Alias, models could be translated from one modeller to the other.
- Modular software enabled expansion to make the system more comprehensive.
- A built in STL^{xiv} file translation protocol enabled direct communication with Rapid Prototyping Technologies.
- It is a parametric modeller, which means that all the history related to the creation of a model is retained and any change to the model that affects another part of the model results in an automatic update.

^{viii} I-Design™: see Glossary

^{ix} I-DEAS™: see Glossary

^x CDRS™: see Glossary

^{xi} Pro/Engineer: see Glossary

^{xii} Euclid™: see Glossary

^{xiii} 3D Go™: see Glossary

^{xiv} STL: see Glossary

- The review indicated that Pro/Engineer was emerging as a market leader; consequently the decision was made to adopt Pro/Engineer as the complimentary research software.

2.6.2 Software Interface Assessment

The aim of this phase of research was to “investigate the interface between the industrial designer and a 3D surface modeller”. At this point in the research the learning curve on 3D systems was perceived to be a major stumbling block to their implementation, the intention of this aim was to investigate the nature of the learning curve on Alias from a designers viewpoint. The method, taken from established teaching processes, was one of linear reinforcement⁹⁸, with the researcher learning the system first, and then teaching it to a novice student. The learning, teaching process re-enforced the fundamental system logic and enabled the evaluation of common problem areas. The objective was to provide an intuitive learning and teaching method. Durling⁹⁹ points out that learning and teaching needs to be as appropriate to the tutee as possible, otherwise learning efficacy may be seriously impaired. The learning and teaching processes were recorded on daily worksheets, documenting progress in both written and sketch forms^{xv}. Utilising the teaching method of linear reinforcement a method was derived which followed three key phases:

- *Background Reading*: assimilation of learning documents supplied with the software.
- *Learning*: Empirical learning through the creation of a 3D model of a previously designed object^{xvi}.
- *Teaching*: Immediately following learning, teach the system to a novice student^{xvii}.

^{xv} See Appendix 1.2.1 & 1.3.1 for examples

^{xvi} See Appendix 1.2

^{xvii} See Appendix 1.3

The objective of the software assessment was to make a judgement regarding the learning curve on the system and any factors directly affecting the building of a model.

What was found was that the learning curve on Alias appeared to be less significant than first thought; it appeared that there were specific factors likely to affect the users ability to create a model effectively:

- Understanding is much greater when exploratory techniques were employed, i.e. if, before a modelling task was attempted, a range of modelling approaches was discussed and preliminary test models carried out.
- The modelling process is more effective if there is a good understanding of the geometry of the intended object. The better users understand the geometry of what they are trying to create the more the modelling process becomes a tactical process of tool and technique selection.
- The flexibility of a model is relative to the integrity of the construction process. If a model is 'badly' built then a change may require rebuilding rather than modification of the model.

A tangible outcome of this phase was the creation of a set of quick reference 'diagram cards'^{xviii}, these consisted of an easy to understand explanation of the core modelling concepts inherent within the Alias software. These were created as a result of an analysis of the interface and dissemination of the major concepts and procedures throughout the learning process. These cards crystallised the understanding of the software enabled through the learning process and were subsequently used as part of the teaching process to assist in the tutee's understanding of system concepts and procedures.

^{xviii} See Appendix 1.2.3 for examples

2.6.3 The Contribution of the Pilot Study to the Research Decision Making

The addition of a solid modeller to the resource set significantly broadened the scope of the research. Prior to the acquisition of Pro/E, Alias was the only software available. By default therefore, the initial part of the investigation had studied the use of surface modelling only, which was done in pursuit of the first research aim:

Investigate the interface between the industrial designer and a 3D surface modeller, Alias. Further, due to the inherent characteristics of the software (previously discussed in 2.2.2) the initial phase of the study looked only at the conceptual stages of the design process.

However, the findings of the software assessment showed the initial premise; that the complex nature of the software made the leap from 2D to 3D inherently difficult; to be incorrect. The software itself was found to be much less relevant than was first assumed, it was how, when, and where it was used that really mattered. This pilot study therefore served to inform the decision to take the scope of the research to a broader and less software specific level.

The teaching and learning process contributed to the research decision making in that it familiarised the researcher at first hand with one of the key pieces of research software. Through this activity it was found that the previously perceived problems with learning the software interface were not significant. This was very important to the direction of the investigation, up to this point the focus of the study had been on findings ways to solve the perceived problems that learning the software were presenting. When it became clear that whilst difficult to learn, the software was not providing a significant barrier to use, the idea of when and how to integrate it within the design process became much more important than finding ways to make it easier to learn.



2.6.4 Formative Case Studies

The aim of this phase of research was to: *“identify possible tactics for the implementation of virtual modelling at strategic points within the design process”*.

The principal objective was to investigate methods by which the adopted research software, Alias (at this point in time the only available software), could be used for the creation of virtual models as an integral part of the industrial design process.

Both of the case studies were based on live projects, but were much smaller in scale and complexity compared to case studies carried out later in the research programme.

The use of 3D modelling as part of their execution was not specified in the original client brief. We were able therefore, to apply an experimental cyclical research framework to the use of 3D modelling software as part of their execution. The framework used a combination of personal activity and peer review. The application of action research methods within these studies represents an important phase in the overall development of the methodological approach for the investigation:

- Pre-modelling discussions: definition of experimentation route (team)
- Experimentation (self)
- Evaluation of experimentation (self / team)
- Refine tactic (self)
- Execute project (self)
- Evaluation (team)

See Appendix 1.4 for a fuller explanation of the following case studies. Supporting images for these case studies can be found on the CD.

2.6.4.1. Case Study 1: Seaward Electronics

This case studied the design, modelling and presentation of two products: an oscillator unit and an amplifier probe. Both products house electronics, and have to be compliant with a stringent set of specifications.

The Brief: Develop schematic electronics layouts and design the casings for an oscillator and amplifier probe to refined concept level, taking into account all technical components and associated specifications.

Requirement: The end result had to be sufficiently rationalised and of suitable quality for the products to be part of a tender for an impending BT contract.

Response: The project had two key requirements: designing an appropriate casework around a set of electronic components, and presenting the design convincingly to a potential customer (BT) in a manner that would convince the customer that the design was feasible. The design problem was reasonably technical, and therefore the rationalisation of the various spatial and design problems was most suited the engineering rigour of Pro-Engineer. On the other hand, the presentation medium had to be as indicative of the final product as possible, a requirement more suited to the visualisation capabilities of Alias. The combination of technical content and the required sophistication of the presentation involved in the project meant that it lent itself to the combined use of Alias and Pro/Engineer, with final form presentation visuals created on Alias.

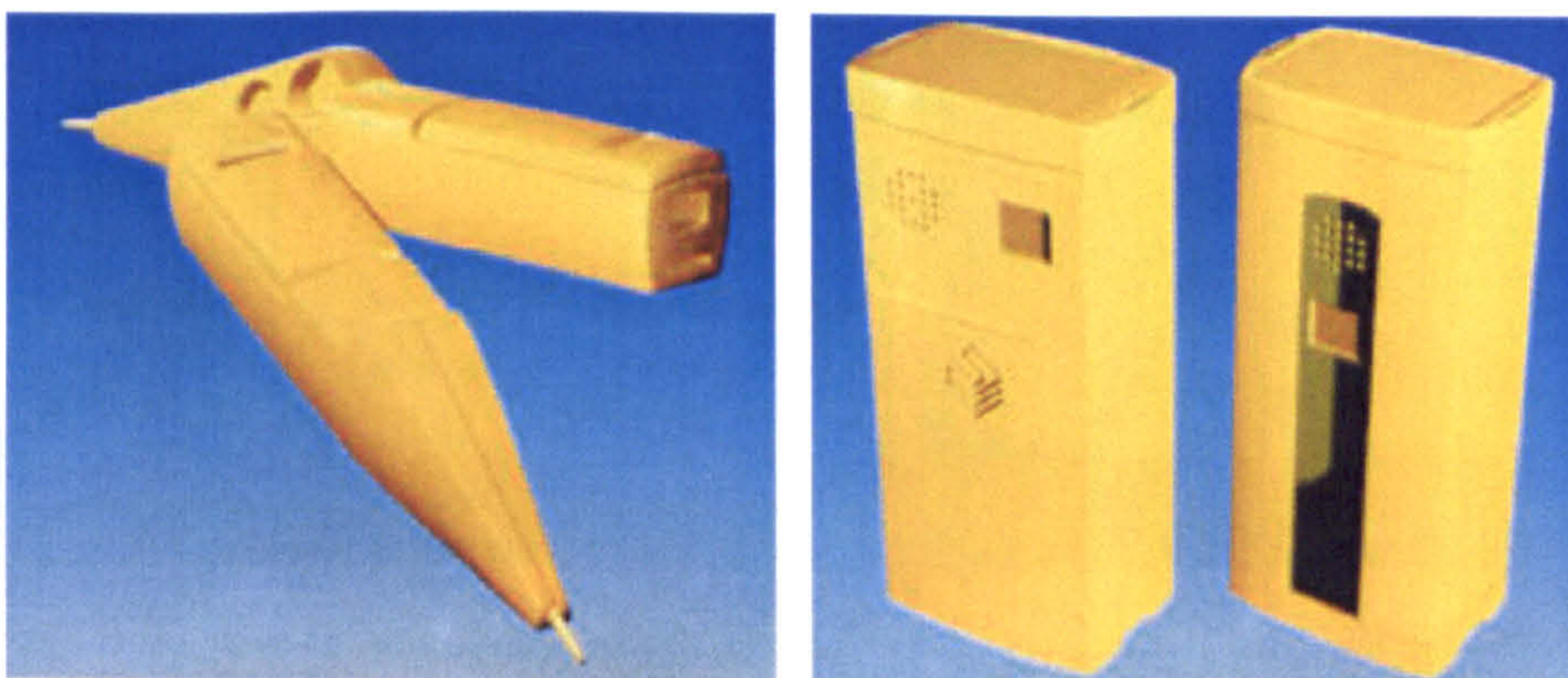

Fig. 1. Final computer visualisations of amplifier probe (left) and oscillator (right) concepts.

2.6.4.2. Case Study 2: Daniel Thwaites Ltd

This case studied the design, modelling and subsequent presentation of proposals for two counter mount concepts. These were primarily point of sale products with few functional constraints.

The Brief: Design a range of counter mounts taking into consideration brewery history, the nature of the family of products, as well as current and potential markets.

Requirement: Represent the concepts at a level where they can be presented to the board of directors.

Response: To make a prototype for this type of product would be prohibitively expensive and the client did not have the budget to do this. However, in order to make the important commercial decision of whether to proceed with the project and if so, which design to proceed with, it was important that they were able to see the product as close to reality as possible. The presentation had to be of an appropriate realism that it made a full and accurate representation of both the proposed mount and the associated graphics. In order to achieve this, the 3D models of the design proposals were shown in the context of a pub, photos of which were texture mapped to the inside of a cube, this enabled the counter mounts to have accurate reflections. Further texture mapping achieved a realistic representation of the proposed materials and graphics. These visualisation requirements are complex and ideally suited to the visualisation capabilities of the Alias software.



Fig. 2. Early computer visualisations showing the two concepts with graphics

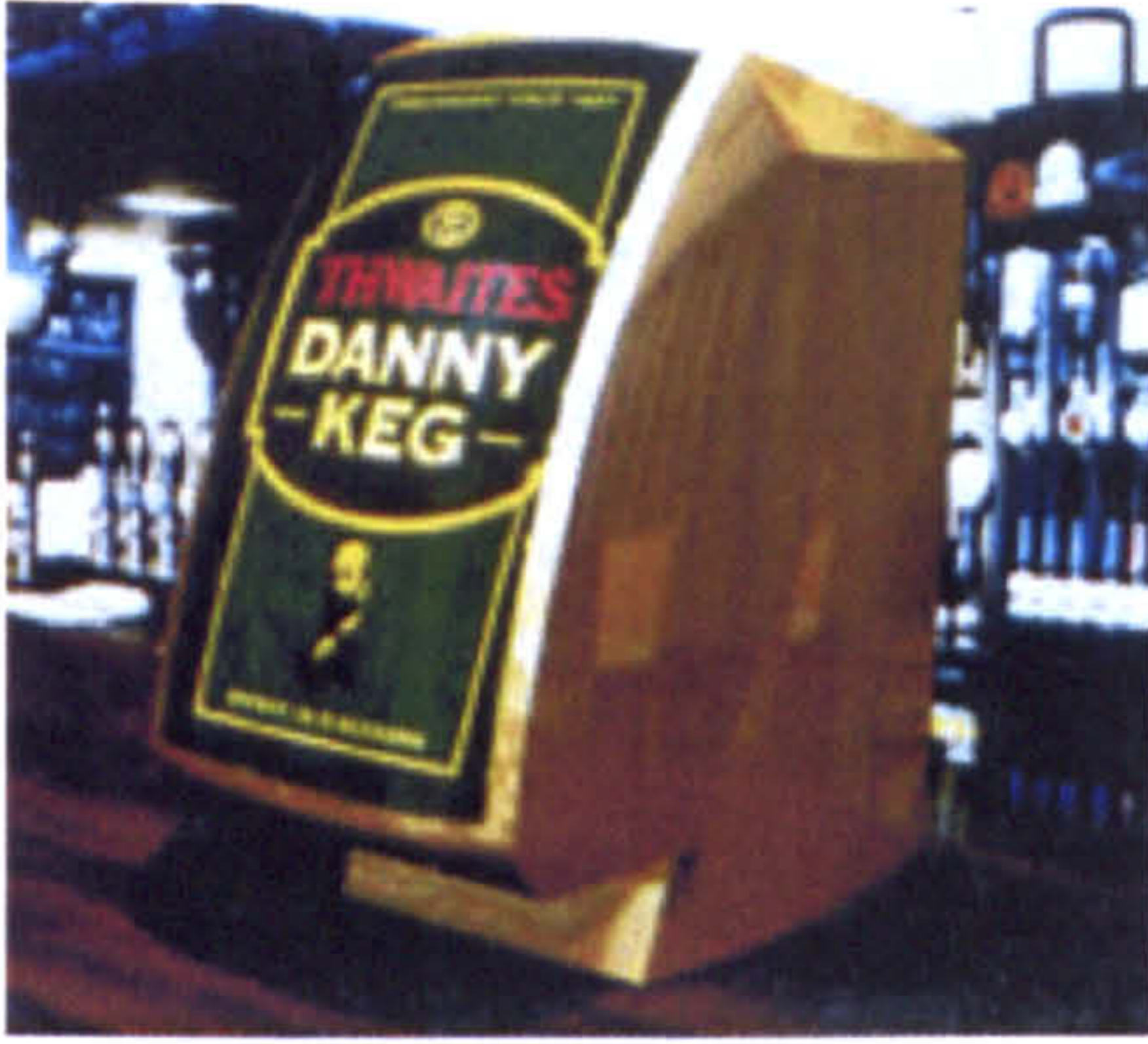

Fig. 3. Final computer visualisation showing the selected concept with final graphics in context

Case Study Findings

Initially, the challenge of *how to build the model* was perceived to be of great significance, the software had a learning curve that could present a real stumbling block to designers. The pilot study showed this not to be the case and indicated that in time, acquiring virtual modelling techniques would become like learning any basic design skill. Further, it is suggested that the appropriation of 3D modelling skills will become as conventional in design education as learning traditional skills such as model-making and become commonplace in the designers skill set. The findings from the learning and teaching processes had suggested that the question of tool selection in terms of building the model was not as critical as had been initially thought. This became further apparent during the execution of the case studies and experience with the Seaward and Thwaites projects further suggested that how the models are used as tools to verify and present design decisions was of greater significance to the designer. 3D modellers are seen as an addition to the tool-set, and therefore should be considered in terms of their integration with the totality, rather than in terms of the acquisition of discrete 3D modelling skills. The question shifted in emphasis from; *'How do I build this model?'*, to; *'What can I do with it once it is built?'*.

Shifting the emphasis from the creation of the model, to the use of the model as a tool for decision making re-focused the study, and removed the problematic aspect of it being software specific. The study would broaden to accommodate all forms of 3D

modelling, the differential between solid and surface modelling would be broken down, and it would be *3D digital modelling media*, which would become the focus of the investigation.

2.6.5 Formative Research Findings

As a result of the software interface assessment and the execution of the formative case studies a number of propositions as to the status of 3D modelling within the industrial design process were made. All of the propositions are interlinked but can be summarised as follows:

Integrity versus Flexibility, i.e. the integrity of the construction path may affect the future flexibility of the model.

This proposition encapsulates the concept of ‘laying good foundations’. Although this is often seen as an issue more endemic in the use of parametric architectures, where the entire history of the model is maintained, it can also raise problems with more flexible surface modellers. If a designer builds a model in an ill considered or haphazard way, he/she may preclude further edits being made to that model at a later date. When modelling, the designer needs to consider how they are building the model, to ensure that as much flexibility as possible is built in at ‘ground level’. It may be seen as similar to the analogy of building a house; a house built on poor foundations may not withstand the rigours of more building work being done on that site. An example of this was apparent in the Thwaites case study, where the cheek modelling of the horse head had caused continual problems, until it was realised that the construction geometry was just not capable of being edited to the design intent and therefore that part of the model had to be completely re-worked from scratch. This reiterates the need for the designer to be able to clearly visualise what it is that he she wants to model before commencing with the process; thereby reducing the potential for creating non-editable modelling geometry in the future.

Interpretation versus Clarity of Presentation, i.e. *the mode or method of presentation may affect interpretation of form, finish, complexity and project progress.*

This proposition relates to how the clarity of the presentation of a concept can affect the perception of that concept by others. For example: if a designer was to present a solution to a design problem merely in the form of a sketch, the problem may have been solved, but the client may find it difficult to perceive the proposed design or that the problem had been adequately solved to proceed. However, should the designer respond at the same point with diagrams, models and perhaps some form of 3D digital visualisation – such as a computer model, the client may well be more disposed to believe in the efficacy of the proposed solution. Although this is quite an extreme example, such principles can be carried through to the area of 3D modelling. 3D models can be made manifest in many ways: wire-frame, simple shaded, photo-realistic, animation etc. If, at a first stage presentation, a 3D model is presented, as a photo-realistic animation, it might easily be perceived by the client that the design is complete, when in fact the proposal may well be completely superficial. On the other hand, presenting a client with only a wire-frame model may not be adequate to communicate the design intent. It is critical that the designer choose the correct level of visualisation for the 3D model to match the expectations and requirements of the stage of the project that is being presented. This need was illustrated by the existence of a piece of software seen at the CAD/CAM show in 1992. Essentially a technique for mapping textures, it would render Alias files with a less ‘perfect’ texture, such as coloured pencil, airbrush or marker, suggesting that the image had been created by a more traditional method and that the design was therefore less ‘finished’.

Appropriate use of Model versus Design Development, i.e. *the decision to use computer modelling may affect the development of that design.*

This proposition refers to the effect of introducing 3D modelling at different points within the time frame of the design process, as well as the appropriate use of the 3D model throughout all aspects of it. The proposition suggests that if a 3D model of a design proposal is attempted too early, the 3D model may not be flexible enough to

develop as quickly as the design thinking. This may be for a number of reasons; the first is linked to another of the propositions, that the integrity of the model build may affect the future flexibility of the model, where the original model may not have enough inherent flexibility to develop in parallel with the design. Second, the skill of the designer may not be adequate to manipulate the model as quickly or effectively as they might wish, this may lead to the situation where the software drives the design rather than vice-versa. Third, however skilled the operator, a 3D model takes a reasonable time to build, working in sketches or sketch models can often be much quicker and provide perfectly adequate feedback. Introducing a 3D model too early may slow the progress of thinking down to a point that it affects the creative development of the design.

The use of 3D modelling will probably affect how the design project is run and how that design appears at the end of the process. Using 3D the design is more likely to maintain design intent, for example in the Thwaites project: the final product in the pub was exactly the same as had been seen on the computer model. This is because once the design had been approved in its visualised form on Alias, it was translated into Pro/E and re-created as a solid model file in order to provide the data for manufacture. This meant that the design intent was maintained from start to finish. It was appropriate to use the visualisation capabilities of the software to present the concept to the client, and appropriate to use the 3D solids software to communicate the specification information to the manufacturer.

Therefore, if used at all, it is essential to choose the right point in time to introduce the 3D model, not so soon that it conflicts with natural thinking, but soon enough to take advantage of the benefits.

Clarity of Communication versus Decision Making, i.e. *decision making may be affected by the clarity of communication.*

Design decisions are made taking into account a range of factors. How well the design is represented at the point at which these decisions are made will play a vital part in the process. The form of communication used should take into account the type of project, the requirements of the project and an assessment of the client's expectations. The more clearly all the aspects of the design are communicated the more likely the designer and the client are to make decisions that are beneficial to the development of both the design and the project in general.

In the Thwaites case study it was found that the client's perception of the model of the product was considerably affected by the presentation technique. The client found it difficult to interpret or understand the concept when presented with no reference to the context in which the final product would be placed, e.g. a public house. However, once the visualisation of the product was displayed in a way that made it look as close as possible to the way it would look in its natural environment, as in Fig. 3, commitment to the design became much more positive.

Another clear example can be seen in the representations of the designs for Seaward electronics. The contextual issues were not important, however clear communication of the different elements of the design was. These designs were more functionally, than aesthetically critical, and clear communication of these functional aspects was essential. Therefore the level of communication had to be clear and precise, rather than glamorous.

The finding that a clear understanding of geometry was instrumental in effective model building suggested that perhaps a 3D modeller was not a creative tool in itself. It was seen that 3D modelling was most appropriate once the intended form had been rationalised and that what was required was a level of verification realisable only by some form of 3D representation. The decision to build a 3D model may be driven by a number of factors, e.g. the final presentation requirements where perhaps many

colour and graphic options are required, with these factors affecting the integration of 3D models into the design process. These first stages of the research programme were exploratory in nature and served to shape and refine the research question to have a greater focus during the final stages of the study. The execution of further case studies would seek to establish the relevance of the factors identified.

¹ McCULLAGH, K. 3D computer modelling in industrial design. in *Co-Design Journal*, 07.08.09, 1996, p. 28-35.

² BAKER, R. *Designing the Future*, Thames & Hudson, 1993.

³ FERGUSON, E. *Engineering and the minds eye*. MIT Press, Cambridge, 1994, p. 23.

⁴ MAIER, C. All together now, in *Design*, April 1994, p. 30-33.

⁵ MCCULLAGH, K. Op. cit.

⁶ MYERS, B. A. A Brief History of Human Computer Interaction Technology, in *ACM Interactions*. Vol. 5, no. 2, March 1998, p. 44-54.

⁷ JONES, T & FEARIS, P. Computer integrated design within product design consultancy, in *Co-Design Journal*, 07.08.09, 1996, p. 80-85.

⁸ BAKER, R. Op. cit.

⁹ MCCULLAGH, K. Op. cit.

¹⁰ HUIISH, P. Simultaneous engineering with respect to direct CAD-based Simulation Analyses Models, at *Virtual Representations for Design and Manufacture Symposium*, Coventry University, December 16, 1992, p. B3.

¹¹ HOLLINS, B. The management of concurrent engineering and total design, in *Co-Design Journal*, 04.05.06, 1995, p. 22-27.

¹² MORTIMER, J. and HARTLEY, J. *Simultaneous Engineering: An executive guide*. DTI, London, 1991.

¹³ LLOYD, M. The culture of connectedness, in *Co-Design Journal*, 07.08.09, 1995, p.12-14.

¹⁴ 'Product Design and 3D Computer Modelling' - Conference, Sheffield City Polytechnic, April 7, 1992.

¹⁵ DRURY, J. Computer Aided Design at Black & Decker, at *Product Design and 3D Computer Modelling Conference*, Sheffield City Polytechnic, April 7 1992.

¹⁶ RUST, C. et al. *The management of information technology in the professional practice of three dimensional design*. Sheffield Hallam University, ISBN 0863393748, 1993.

¹⁷ McCULLAGH, K. *Investigating the factors which influence the strategy of integrating three dimensional computer aided design techniques within industrial design consultancy practice*. PhD Transfer Document. UNN, September 1993. Interviews with IDEO & Tangerine May 1992, p. 11-12.

¹⁸ RUST, C. et al. Op. cit.

¹⁹ LAING, L. W. W. Book Review of, Kennedy, L. E: 'CAD: drawing, design and data management', The Architectural Press, London, 1986, in *Design Studies*, Vol. 9, No. 1, January 1988.

²⁰ CROSS, N. Styles of learning, designing and computing, in *Design Studies*, Vol. 6, No. 3, July 1985, p. 157-162.

²¹ SIODMOK, P & COOPER, A. *Advanced 3D CAD methodologies used in contemporary industrial design practice* at 'Hong Kong Productivity Council Conference', Hong Kong, March 2000.

²² McCULLAGH, K. 3D computer modelling in industrial design. in *Co-Design Journal*, 07.08.09, 1996, p. 28-35.

²³ RUST, C. Out of the hothouse, in *Co-Design Journal*, 07.08.09, 1996, p. 16-21.

²⁴ JONES, T & FEARIS, P. Op. Cit.

²⁵ SHICKLE, M. A new way to think about product development at *Networking Design*, Design for Industry Course Conference, UNN, March 21, 1996.

²⁶ ARCHER, B. *Design as an interdisciplinary domain*. Paper presented at DRS Council Meeting, University of Derby, 20th September 1996.

²⁷ 'Product Design and 3D Computer Modelling' - Conference, Sheffield City Polytechnic, April 7, 1992.

²⁸ RUST, C. et al. Op. Cit.

²⁹ 'Virtual Representations for Design and Manufacture' - Symposium, Coventry University. December 16, 1992.

³⁰ 'Information Technology & Design: New Perspectives' – Conference, University of Central England. February 16, 1993.

³¹ 'Computer Aided Industrial Design – Reflections & Insights' – Conference, UNN, 1993.

-
- ³² 'Design of the Times' – Conference, Staffordshire University. October 5, 1994.
- ³³ '4D Dynamics: an international interdisciplinary conference on design and research methodologies for dynamic form', De Montfort University. September 21, 1995.
- ³⁴ 'CAD, Colour & Communication' – Conference, University of Derby. September 20, 1996.
- ³⁵ CADE 97: 'Digital Creativity' – Conference, University of Derby. April 1997.
- ³⁶ WHITEHEAD, J. Creating a living educational theory from questions of the kind, 'how do I improve my practice?', in *Cambridge Journal of Education*, Vol. 19, No.1, 1989.
- ³⁷ DORMER, P. *Design since 1945*, Thames & Hudson, 1993.
- ³⁸ CROSS, N. *Engineering Design Methods*. John Wiley & Sons, Chichester, 1994 (2nd Ed.), p. 21.
- ³⁹ DORMER, P. Op. cit.
- ⁴⁰ DORMER, P. Ibid.
- ⁴¹ CROSS, N. Op. cit.
- ⁴² DORMER, P. Op. cit.
- ⁴³ DORMER, P. Ibid.
- ⁴⁴ ARCHER, L. B. *Systematic method for designers*. In: N Cross (ed) *Developments in design methodology*, Wiley, Chichester, 1984.
- ⁴⁵ JONES, J. C. *A method of systematic design*. In: N Cross (ed) *Developments in Design Methodology*, Wiley, Chichester, 1984.
- ⁴⁶ HICKLING, A. *Beyond a Linear Iterative Process?* In, *Changing Design*. (Eds) B. Evans, J.A. Powell, and R.J. Talbot, John Wiley & Sons, 1982.
- ⁴⁷ CROSS, N. Op. cit. p. 19.
- ⁴⁸ CROSS, N. Op. cit. p. 21
- ⁴⁹ PAHL, G. AND BEITZ, W. *Engineering Design*, Design Council, London, 1984.
- ⁵⁰ HICKLING, A. Ibid.
- ⁵¹ ARGYRIS, C. *Increasing leadership effectiveness*, Wiley, New York, 1976.

-
- ⁵² MARCH, L. J. *The logic of design*. In: N Cross (ed) *Developments in design methodology*, Wiley, Chichester, 1984
- ⁵³ HICKLING, A. Op. cit.
- ⁵⁴ BRUCE, M. The design process and the 'crisis' in the UK information technology industry, in *Design Studies*, Vol. 6, No. 1, 1985, p. 34-40.
- ⁵⁵ BRITISH STANDARD BS 7000. *Guide to managing product design*, BSI, London, 1989, p. 3.
- ⁵⁶ HICKLING, A. Op. cit.
- ⁵⁷ FRENCH, M. J. *Conceptual design for engineers*, Design Council, London, 1985.
- ⁵⁸ PURCELL, P. *The Electronic Design Studio*, MIT Press, Editors Purcell, P (w/ MITCHELL, WM. & MCCULLOGH, M.), Cambridge Mass. & London, 1990.
- ⁵⁹ PURCELL, P. Computer environments for design and designers, in *Design Studies*, Vol. 9, No. 3, 1988, p. 144-49.
- ⁶⁰ MAVER, T. W. *The future of CAAD: Can we get there from here?* Keynote address at ACADIA 96, Tucson, USA, 1996.
- ⁶¹ MAVER, T. W. Social impacts of computer-aided architectural design, in *Design Studies*, Vol. 7, No. 4, October 1996, p. 178.
- ⁶² LAWSON, B. *How Designers Think*, Butterworth Architecture, 2nd Ed. June 1991.
- ⁶³ TOVEY, M. Drawing and CAD in industrial design, in *Design Studies*, Vol. 10, No. 1, 1989. p. 24-39.
- ⁶⁴ TOVEY, M. Form Creation Techniques for Automotive CAD, in *Design Studies*, Vol. 15. No. 1, 1994. p. 85-114.
- ⁶⁵ ARCHER, B. The nature of research, in *Co-Design Journal*. 07.08.09, 1995, p. 6-13.
- ⁶⁶ RUST, C. et al. Op. cit.
- ⁶⁷ RUST, C. Op. cit.
- ⁶⁸ McCULLAGH, K. Op. cit.
- ⁶⁹ McCULLAGH, K. *Investigating the factors which influence the strategy of integrating three dimensional computer aided design techniques within industrial design consultancy practice*. PhD Transfer Document. UNN, September 1993.

-
- ⁷⁰ HUNDAL, M. S. Recent computer related design in the USA, in *Design Studies*, Vol. 12, No. 4, October 1991.
- ⁷¹ JOHNSON, A. L. & THORNTON, A. C. Towards real CAD, in *Design Studies*, Vol. 12, No. 4, October 1991.
- ⁷² CROSS, N. Styles of learning, designing and computing, in *Design Studies*, Vol. 6, No. 3, July 1985, p. 157-162.
- ⁷³ TOVEY, M. Intuitive & Objective Processes in automotive design. in *Design Studies*, Vol. 13, No.1, 1992. p. 23-41.
- ⁷⁴ PRYCE-JONES, D. Conceptual Design using 3D computer modelling, at *Product Design and 3D Computer Modelling Conference*. Sheffield City Polytechnic, April 7, 1992.
- ⁷⁵ TOVEY, M. & DEKKER, K. CAD & Virtual Representation for Industrial Design, at *Virtual Representations for Design and Manufacture Symposium*, Coventry University, December 16, 1992.
- ⁷⁶ PRYCE-JONES, D. Interfacing Industrial Designers with CAD, at *Information Technology & Design: New Perspectives Conference*, University of Central England, February 16, 1993.
- ⁷⁷ TOVEY, M. Form Creation Techniques for Automotive CAD, in *Design Studies*, Vol. 15, No. 1, 1994. p. 85-114.
- ⁷⁸ SUNTHARALINGHAM, P. Alias and the Design Process, at *Information Technology & Design: New Perspectives Conference*, University of Central England, February 16, 1993.
- ⁷⁹ TEMPLE, S. Thought made visible - the value of sketching, in *Co-Design Journal*, 10.11.12, 1994, p. 16-25.
- ⁸⁰ SCRIVENER, S. A. R & CLARKE, S. M. *Sketching in collaborative design in Interacting with Virtual Environments*, Wiley, 1994.
- ⁸¹ VAN DIJK, C. G. C. New insights in computer aided conceptual design, in *Design Studies*, Vol. 16, No 1, 1995. p. 62-80.
- ⁸² HERTZ, K. A coherent description of the process of design, in *Design Studies*, Vol. 13, No 4, 1992. p. 393-410.
- ⁸³ DURLING, D. Intuition in Design, in *Bulletin of 4th Asian Design Conference*. International Symposium on Design Science, Nagaoka, Japan, October 1999. ISBN 4-9980776-0-0 C3072.

⁸⁴ PEDGLEY, O. F. *Industrial designers' attention to materials and manufacturing processes: analyses at macroscopic and microscopic levels*, PhD thesis. Loughborough University, Loughborough, 1999.

⁸⁵ BUNNEL, K. *Re: Presenting Making*, the integration of new technology into ceramic designer-maker practice, Ph. D. Thesis, Gray's School of Art, The Robert Gordon University, Aberdeen, 1998.

⁸⁶ DURLING, D. Review of CD of Ph.D. thesis by BUNNEL, K, *Presenting Making*, posted on DRS discussion list, 12 May 2000.

⁸⁷ SHICKLE, M. *Op. cit.*

⁸⁸ JONES, T & FEARIS, P. Computer integrated design within product design consultancy, in *Co-Design Journal*, 07.08.09, 1996, p. 80-85.

⁸⁹ HUGHES, C. & CUNNINGHAM, L. Design creativity – with a mouse? In *Co-Design Journal*, 07.08.09, 1996, p. 86-88.

⁹⁰ WALKER, D et al. Editorial Notes, in *Co-Design Journal*. 01.02.03, 1995, p. i-ii.

⁹¹ MURANKA, T. & ROOTES, N. *Doing a Dyson*, Dyson Appliances Ltd. Malmesbury, 1996. ISBN: 0 9528935 0 9.

⁹² ARCHER, B. *Op. cit.*

⁹³ CLIPSON, C. Redesigning design: some critical dimensions for research, in *Co-Design Journal*. 01.02.03, 1995, p. 22-28.

⁹⁴ ARCHER, B. *Design as an interdisciplinary domain*. Paper presented at DRS Council Meeting, University of Derby, 20th September 1996.

⁹⁵ McNIFF, J. *Action Research - principles and practice*. MacMillan, London, 1988.

⁹⁶ ALEXANDER, C. *Notes on the synthesis of form*. Harvard University Press, 1964.

⁹⁷ SIODMOK, P & COOPER, A. *Op. Cit.*

⁹⁸ RAMSDEN, P. *Learning to teach in higher education*. Routledge 1992.

⁹⁹ DURLING, D., CROSS, N. & JOHNSON, J. CAI with Style. In: *Proceedings of SEED 96* (Conference on sharing experience in engineering design), 26-27 June, University of Bristol.

Chapter 3: Methodology

"I think it is absurd to separate the study of designing from the practice of design."

Christopher Alexander. Notes on the synthesis of form. Harvard University Press. Fifteenth Ed., 1999, p. ii.

3.0 METHODOLOGY

3.1 Introduction

This chapter outlines the methodological framework within which this research investigation was carried out. It comprises three principal elements, the first setting the historical context, the second discussing the arguments for the methodological approach, the third describing the actual 'methods' which were employed.

A brief review of the history of design methodology enables understanding of the development of the subject and to identify the roots of methodological concepts. An exploration of the relationship between practice and design theory identifies the importance of the educational tradition from which much of the chosen Action Research methodology has developed. There then follows an explanation as to why this project is appropriate to an Action Research approach and how the techniques and practices were implemented.

The section on the historical development of design methodology describes what has been studied and investigated in the past and enables the researcher to establish the novelty of the investigation. The thesis suggests that 3D CAD has significantly changed the way in which people design and has as a consequence, significantly affected the methods that we use to achieve an end result. It is therefore essential to understand and acknowledge the history of design methods in order to see how they have changed. This study adopts and adapts its methodology from a number of different camps; it is therefore appropriate to acknowledge the influence of the study of design methods both contemporaneously as well as historically. Alexander¹ rejected the concept of the study of design methods as being too academically focused, however the researcher believes and others have shown, that design methods can be studied within the practice context, as Archer states:

*“Design methods is the field of study that has matured into the contemporary field of design research.”*²

3.2 The Historical Development of Design Methodology

Compared to the more established fields of science and humanities research, design methodology is a relatively new field of research, and as such, its history is charted through a relatively limited number of papers, conference proceedings and established texts. As with many other literature reviews, the following will draw heavily on the seminal text ‘Developments in Design Methodology’³. This text serves to set the scene for further discussions on the development of design methodology in this thesis. The four sections of the text; *the management of the design process, the structure of design problems, the nature of design activity and the philosophy of design methods*, effectively chart the historical & philosophical development of design methodology through what Broadbent⁴ describes as the first, second and third generation of design methods over a twenty year period from the first Conference on Design Methods held in London in 1962 to the Design Policy Conference in 1982. Cross⁵, describes these as marking the ‘birth’ and ‘the coming of age’ of design methodology.

3.2.1 The Management of the Design Process

This marks a period of ‘systematic design’ thinking during which attempts were made to make the design process more efficient through the implementation of rigorous procedures. The rationale was that for designers to respond to developments in technology, especially computing, combined with the increasingly complex nature of the design task, would require radical new techniques for managing the design process.

In ‘A method of systematic design’⁶ Jones argues for the combination of the rigour of mathematical and logical thinking with the intuition of the designer to supplement traditional methods. The idea was that separating creative from logical thought by

externalising all the logical aspects leaves the designer free to be creative. The framework for this is a linear process of *analysis, synthesis & evaluation*. The aim of this process was to reduce design errors & delays, thus enabling more imaginative and advanced design.

In his paper 'The determination of components for an Indian Village' Alexander⁷ follows an exhaustive definition of the requirements thrown up by the problem context. Linking the requirements into subsets, for which solutions are designed, creates subsystems of the problem context. Alexander went on to use this paper as a stepping stone to his later work 'Notes on the synthesis of form'⁸, where he explores the creation of diagrams and patterns as being key to the process of creating form.

Essentially reductionist in nature, Archer's⁹ approach is more artefact or idea focused. Like the others, he stresses the full collection of information before any critical design decisions are made. The core of his model is a six-stage process: *programming, data collection, analysis, synthesis, development & communication*. He acknowledges, however, that in practice this is reduced to a 'creative sandwich', the centre section of which may comprise any number of 'creative leaps' and 'feedback loops' much of which is determined by the designer's experience and creative ability.

Luckmans¹⁰ model can be seen as a development on the work of both Archer and Jones. It has as its basis the linear; *analysis, synthesis, evaluation* model, but presents it as a continuous cycle occurring at different levels of design detail as the designer breaks problems down into sections and sub-sections.

All four follow a common thread in that they involve in-depth problem exploration followed by the breakdown of the problem into smaller ones and then trying to synthesise a series of partial solutions into a complete one. However it is Luckman who acknowledges the cyclical iterative nature of design as the designer proceeds

from general to specific problems requiring a holistic rather than step-by-step approach.

3.2.2 The structure of design problems

Further developments resulted in investigation into the way design problems are structured. Luckman¹¹ had already expressed the cyclical nature of design iteration, Levin¹² developed this by characterising design problems in terms of having controllable causes and controllable effects, in effect design parameters and variables. He determined the need for an ‘ordering principle’ such as a geometric pattern in order to identify a clear order of decision-making.

Alexander & Poyner¹³ objected to such arbitrariness in the design process suggesting that it was inherently subjective. They argued that needs were impossible to ascertain and instead present a concept of ‘tendencies’, a statement which is like a hypothesis, open to testing and refinement. A design problem only exists when there is a conflict in tendencies. Following a similar path to the Alexander model, the designer must create relationships avoiding these conflicts. The intention is to create an externalised, objective body of knowledge similar to scientific knowledge through which designing will be objective rather than intuitive, driven by fact rather than value.

This issue of conflict is taken up by Rittel & Weber¹⁴, who argued that a problem cannot be understood independent of context. This essentially marks the turning point to ‘second generation’ methodologies, which acknowledge the design process as subjective and value led. They determine a split between ‘tame’ problems and ‘wicked’ problems; tame problems can be solved by scientific means, whereas wicked problems are solution driven.

Simon¹⁵ however, argues that there is no real difference between ‘well structured’ and ‘ill structured’ problems, rather that the process of ‘taming’ problems is the process of structuring them and that current logical processes are adequate. The

process of design therefore consists of moving from one sub-problem to the next, the result being a series of sub-solutions. The drawback is how to amalgamate these into a complete coherent design solution, a compromise with the least negative impact on the final product.

The main agreement is that design problems are inherently ill defined and there are few designers who would not argue that one of the first tasks a designer has to tackle is that of defining the design problem.

3.2.3 The nature of design activity

The investigation of designer behaviour has been carried out through various means from the controlled experimentation of Lawson¹⁶ to the open ended interviews of Darke¹⁷. Darke argues strongly that the designer has a completely solution focused, rather than systems focused approach to the activity of design, we encounter here one of the first examples of the inherent conflicts in using scientific methods to try and understand human behaviour. She states that:

“the research material necessary to understand the design process is not a set of sketches but a knowledge of the mental process the designer goes through”.

This follows the Kuhn¹⁸ and Hillier *et al.*¹⁹ paradigm of conjecture - analysis, where design is seen as a process of ‘variety reduction’ with the very large number of potential solutions reduced by external constraints and by the designers’ own cognitive structures. It expands on the Hillier model proposing the concept of a ‘primary generator’ for conjectures.

Akin²⁰ bases his work on Simon, attempting to break down the design process using protocol analysis. He recognises that design is unique in its constant generation and redefinition of task objectives. Lawson’s²¹ work involved a more experimental approach and identified that science students are problem focused whereas architecture students are solution focused. It follows that designers solve problems through synthesis, scientists through analysis.

Thomas & Carroll²² introduced a model developing the concept of solution & goal focus: *goal statement, goal elaboration, solution outline, solution elaboration, solution testing, agreement/rejection of solution*. They argued that design is as much a way of looking at a problem as a problem in itself.

3.2.4 The philosophy of design methods

At this stage design research appeared to be reaching its 'coming of age', researchers were drawing parallels between their position and developments within the philosophy of scientific research. Popper, Kuhn & Lakatos²³ reject the scientific view of value free knowledge and inductive logic. The philosophical standpoint began to shift to a focus on the designer and artefact. Hillier, Musgrove & Sullivan²⁴ argued that design develops through gradual refinement of conjecture. This accepts that the relevant information the designer will need to resolve the process is incomplete and suggests that design research should help designers pre-structure their problems, thus changing the emphasis from procedures towards the study of artefacts. Daly²⁵ went one step further in suggesting that the nature of designing was outside the bounds of what could be verbally described.

3.2.5 Summary

These main concepts of design methodology, covering a period of 20 years, were mainly generated by a group of researchers and scholars with the involvement of the occasional design practitioner. By the end of this period, both Jones & Alexander had become totally disillusioned with design methods and methodology. Alexander was very firm in his rejection, stating:

*"...a whole academic field has grown up around the idea of "design methods" – and I have been hailed as one of the leading exponents of these so called design methods. I am very sorry that this has happened, and want to state, publicly, that I reject the whole idea of design methods as a subject of study, since I think it is absurd to separate the study of designing from the practice of design."*²⁶

This negative stance was countered by Rittel²⁷, who proposed the concept of 'generations' of design methods. If the first generation was a systematic approach,

then the second could be seen as ‘argumentative’ in which the role of the designer ‘is that of a midwife or teacher rather than the role of one who plans for others’. Broadbent’s ‘third generation’ looked at the conjectures and refutations model, proposing validation by the intended recipient, i.e. user or client. Design methodology emerged therefore newly confident, acknowledging that design methods must not try and follow the processes of scientific or humanities research but be natural to the act of design²⁸.

3.3 Review of methodologies for practice-based research

The premise of this research project is one based on a design practitioner rather than a research practitioner’s approach, therefore this section explores the development and increasing importance of research by design practitioners and how this has in turn driven methodological advances. This history is important to the research because it explores the context within which this study is based and enables a contextualisation of the findings.

3.3.1 What is research?

Archer²⁹ clearly defines research as:

“Research is systematic enquiry whose goal is communicable knowledge...”

- systematic because it is pursued according to some plan;
- an enquiry because it seeks to find answers to questions;
- goal-directed because the objects of the enquiry are posed by the task description;
- knowledge-directed because the findings of the enquiry must go beyond providing mere information; and
- communicable because the findings must be intelligible to, and located within some framework of understanding for, an appropriate audience.”

He also states that the record of activity should be 'transparent', i.e. that the process be duplicable and replicable, with the outcomes validated in an appropriate manner.

In order to establish the position of design research, and particularly the position of practice-based design research, it is essential to look briefly at the key research traditions. Followed by a more in depth description of how these have been developed, particularly within the field of educational research, we see the formation of a practitioner based methodology that is more design oriented, that of Action Research.

3.3.2 Scientific & Humanities Research

Historically, there are two distinct traditions within research: scientific research and humanities research. McNiff³⁰ describes them respectively as the 'empiricist' or 'interpretative' traditions.

The scientific tradition

The *scientific* tradition is most concerned with the formulation, testing and evaluation of hypothesis. Evidence is gathered principally through observation or experimentation and the only valid data are that which can be directly experienced. It is objective and structured, conforming to the principal classifications of: fundamental, strategic, applied and action research³¹. In scientific research all things are viewed as being predictable, regular, explainable and capable of being fitted into a predefined structure: scientific research is essentially quantitative. *True* scientific method appears to seek to disprove, rather than prove hypotheses. This conforms to the Popper³² paradigm described by both Archer and Reich³³ of '*Conjecture followed by refutation*'. The scientific tradition seeks that theory should determine practice.

The humanities tradition

Humanities research on the other hand is essentially qualitative, concerned with expression, creative reflection, interpretation of meaning, exploration of value, categorisation and commentary on ideas, people things & events³⁴. It acknowledges

that the accounts of those ‘researched’ are as valid as that of the researcher and disagreements provide an opportunity for study to try and resolve mismatches. The key difference between this and scientific research is that although this form of research may require empirical or cited evidence, it is value and judgement driven and therefore subjective, researchers are required to take a theoretical or ideological standpoint from which the research must be judged.

Reich³⁵ cites two worldviews within the science tradition. One, which he calls ‘scientism’ conforms to the old values of the science tradition: detachment, neutrality, logic, external validity, universality & generalisability, reductionistic, factual, context free, autonomous, value free, predictability & control³⁶. These are congruent with the scientific or empiricist tradition, as described by Archer³⁷ & McNiff³⁸. The other, which he calls ‘practicism’, has attributes closer to those of humanities research: immersion, experiential, actor, situational relevance, particular, holistic, interpreted, contextually embedded, not separated other fields of knowledge, value laden, promotion of human development³⁹. This presents a more ‘naturalistic’ and ‘democratic’ form of research, which concurs with Archer’s⁴⁰ statement:

“the once unbridgeable differences between science research & humanities research have moved closer together. Whilst science seeks ultimately to explain and humanities still seek ultimately to evaluate, science has become less reductionist in its attitudes and the humanities more empirical”.

Although the evidence suggests that the methodological basis of two traditions have moved closer, it is necessary to look at the key developments within educational research to see a methodology which would be appropriate for practitioner based design research. McNiff⁴¹ argues that the methodologies of the scientific and humanities traditions make predictions or give descriptions of phenomena, but that practice needs a more direct approach for finding out why things happen as they do.

3.3.3 Practitioner Based Research

In the researchers experience there remains a large gap between theory and practice. The methodological review undertaken by this research suggests that educational research has made the greatest steps in closing this gap and design research can learn a lot from it's epistemology. One of the key methodologies of educational research is Action Research, a form of research that provides a method for bridging theory and practice, enabling the development of theories from practice. It provides a series of techniques for self-reflective enquiry with the ultimate aim of improving the quality of practice. Not just restricted to education, Action Research is change-driven and has been used to understand and improve social situations in areas such as industry, health, education & community⁴².

3.3.3.1. Action Research

Although its roots lie in the scientific tradition, the traditional definitions of action research have been almost completely replaced by 'practical' & 'critical' conceptions⁴³ of the methodology. Scientific research tends to be non-interventionist, whereas action research is participatory, requiring the researcher to be a key player or *actor* in the process, taking explicit action in order to 'devise, test or shed light on something'⁴⁴. McKernan describes it as:

*"...a practice in which no distinction is made between the practice being researched and the process of researching it... The aim of action research, as opposed to much traditional or fundamental research, is to solve the immediate and pressing day-to-day problems of practitioners."*⁴⁵

In education as in other fields performance has been judged against traditional precedents, however through an emphasis on critical evaluation the Action Research movement has integrated researchers with a concern to:

*"improve practice and to understand the process of improving practice"*⁴⁶.

Action research attempts to bring objectivity to the subjective process of intervention and change for improvement, however, in order to sustain credibility the researcher must be explicit about the intervention and their ideological standpoint in making it.

Models for Action Research

In 1946 Lewin formed a basis for systematic enquiry, a model for action research that was then refined by Kemmis, Elliot & Ebbutt⁴⁷. Lewins model involved a spiral of four steps: planning, acting, observing, and reflecting. Reflection then leads to further planning and so the cycle continues. Kemmis and Elliot went on to refine this model, Kemmis by reducing the number of control statements at each planning stage, Elliot by increasing the number of actions available within each spiral. Key to Elliot's analysis is that the practitioner is uniquely placed to study the theory of practice and that theoretical understanding is an essential component of practical action & discourse. However, whilst these early models were focused on the practitioner, Ebbutt criticised them for being too prescriptive in their approach, and argued that the spiral model should be extended to contain a series of successive cycles, each with the potential for feedback both within and between the cycles.

McNiff argues the case for a generative framework in which the basic Kemmis/Elliot spiral is maintained but now becomes three dimensional, allowing the researcher to address a number of different problems at the same time without losing control over the main problem.

Action research and the practitioner

There have been a number of educators who have sought different methods to bridge the gap between theory and practice: for example McKernan⁴⁸, Schon⁴⁹ & Whitehead⁵⁰ all argue for an action research approach. Schon⁵¹ argues that there is an enormous amount of tacit knowledge in professional practice and activity, explaining that we know much more than we can make verbally explicit. He goes on to describe how problems can be defined as being from the 'high ground' or 'swampy ground': 'swampy' problems are those which concern human situations and may not even be seen as problems, but as 'messy indeterminate situations'. This is comparable to Rittel & Webbers'⁵² description of 'tame' and 'wicked' problems. Only practitioners are seen to have the skill to frame these situations into addressable problems.

Practitioners make skilful judgements and decisions about these situations in order to define a course of action, based on an intuitive interpretation Schon describes as 'knowing-in-action'. Carrying out the course of action and intervening to reshaping the situation is described as 'reflection-in-action'. It is through observation of and reflection on these moments of action and intervention that researcher practitioners may be able to make tacit knowledge explicit.

McKernan⁵³ argues that rigorous reflection on practice can provide enquiry evidence that can inform theory and improve practice. His definition is that:

“Action research is the reflective process whereby in a given problem area, where one wishes to improve practice or personal understanding, inquiry is carried out by the practitioner - first, to clearly define the problem; secondly, to specify a plan of action - including the testing of hypotheses by application of action to the problem. Evaluation is then undertaken to monitor and establish the effectiveness of the action taken. Finally participants reflect upon, explain developments, and communicate these results to the community of action researchers. Action Research is systematic scientific enquiry by practitioners to improve practice”

Through this definition he makes it clear that he acknowledges the potential criticism of an Action Research approach and seeks to counter this through the definition of a stringent research process. Archer⁵⁴ acknowledges that there is tacit knowledge in all practitioner based activity, but asks some questions about how practitioner activity can be deemed research activity:

“was the practitioner activity an enquiry whose goal was knowledge?

was it systematically conducted?

were the data explicit?

was the record of the conduct of the activity 'transparent'?

were the data and the outcome validated in appropriate ways?”

He concludes that for any practitioner activity to be classed a research activity it must meet the criteria, which define research activity as '*a systematic enquiry whose goal is communicable knowledge*'. He goes on to clarify three classifications with respect to research and practice previously presented by Frayling⁵⁵, when he states that there is;

- research ABOUT practice,
- research FOR THE PURPOSES of practice, and
- research THROUGH THE MEDIUM OF practice.

This study is inherently practice and practitioner-based and therefore is concerned with research through the medium of practice. However, as Schon⁵⁶ points out, it is not easy for practitioners to articulate their implicit processes. To achieve this, it is believed that the most appropriate methods are those offered by an action research methodology.

3.4 Action Research as a Proposed Methodology

3.4.1 Rationale

The proposed methodology for the research investigation will draw primarily on the principles of Action Research. It has already been argued that action research has strong links with practice-led research, but how does it relate specifically to this investigation and how is the research programme actually going to be carried out?

Following on from the educational tradition, Action Research lends itself to any practice-led research programme, one that uses as its research material, the activities and outcomes of everyday living practice. A special feature of Action Research is its closeness to context; it enables the researcher to respond to research findings and to make explicit interventions as the investigation is being carried out. Action Research both implies & means *action* applying to both people and systems, described as

being like ripples in water⁵⁷, action on a small part of the system can have wide ranging repercussions. Halsey⁵⁸ describes this as:

'Small scale intervention in the functioning of the real world and the close examination of the effects of such intervention'.

There is no escaping the latent conflict between action (practice) and research (see Marris and Rein⁵⁹ and Halsey⁶⁰ for a discussion of the problem). Practitioners rarely have time to make an adequate recording of the process as they are going along, let alone to learn the theories associated with what they are doing beforehand. On the other hand, the ability to understand, carry out and implement research is of key importance to professions, and the importance of the potential contribution to knowledge should not be underestimated⁶¹. The main epistemology of the modern educational research movement is focused on "*reflective practice as a process of professional development*"⁶². This should be no different for design; after all, it was Schon who suggested that his 'Reflective Practicum'⁶³ should follow the example set by art & design studios.

The designer and the artefact are central to the design process and design as an activity is solution focused. Action Research is appropriate for design research as it allows the designer/researcher to remain central to the activity of designing and although the technique is process oriented, there is a consideration of the final outcome of the process. Unlike the scientific tradition, it is based fundamentally on change, and the expectation is that the outcome will be an improvement on current practice. Although it is accepted that a participatory procedure is more effective than an imposed process⁶⁴, it is acknowledged that this approach to research requires a range of disciplines⁶⁵.

Due to the affinity of Action Research to the practice-led research programmes described above, it seemed that this methodology might provide an appropriate framework for this study. Research of this type is research *with* rather than research *on*⁶⁶ a domain of study. The adapted implementation of action research proposed for

this project is a kind of naturalistic field research, with an emphasis on heuristics, realism and relevance⁶⁷. Design is all about people and it is argued that research of this type cannot be done through non-participant observation. Action Research provides a method by which tacit knowledge can be made explicit through the activities of a 'reflective practitioner'⁶⁸, where the practice has to be experienced to be understood, but must follow the techniques of participant observation and provide reflection on reflective practice.

Much of research is about asking the right questions as well as solving problems⁶⁹, as some situations require a level of activity before they can be deemed problems capable of being tackled⁷⁰. Action research is not just carrying out professional practice, it is being aware and critical, and using this critical awareness to be open to change and possible improvement. Design is about solving problems through the creation of an improved entity or artefact. Designers are constantly criticising and evaluating what they have done in design terms, and they need to be open to change and improvement. The ideals implicit in such behaviour should be transferable from the design of the artefact, to the method for studying the implications and effects of the designer's intervention.

Action Research aims to give reasoned justification to claims to professional knowledge. It is systematic enquiry made public, which is not random or ad hoc. Although it accommodates the surprise elements of unpredictability and creativity, it seeks to raise intuitive practice to a conscious level. However, in order to understand the implications of issues such as technology on the process, we need to understand what we are doing and why we are doing it. As a practitioner/researcher, this method provides the framework for the most appropriate approach, as most other methods require observation without direct involvement.

3.4.2 Case Studies & Action Research

The principle method of data collection was through the use of case studies. These case studies mirror real world design projects as they were carried out at CfID. The

projects were carried out in a manner typical to the everyday working of the Centre, and all material relating to the projects has been retained and documented in the knowledge that the work would be reflected on as part of an action-reflection cycle, both within the timeframe of the project as well as at a later date.

Reflection on practice, i.e. recording the activities carried out during a case study, and then reflecting on them at a later date, is part of the requirement for an action research methodology. However, this study did not fully engage with all the principles laid out for a full Action Research methodology. Reflection on practice is important but there also needs to be an element of reflective practice and reflection on reflective practice. The methodology applied to this study complied with the principle of reflection on practice. The reflective practice was carried out during the latter case studies forming the subject of the research in line with the researcher's developed understanding of the methodology of Action Research. However, neither these latter case studies nor the formative case studies were recorded as reflective practice accounts. Nevertheless, the reflection-on-practice case study accounts were used as a basis for a cumulative reflection-on-practice in order to derive the generic capacity of the knowledge that they produced. The implication of this approach is that it has more of a similarity to an Applied Research methodology based on case study methods, in that it was: "systematic enquiry directed towards the acquisition, conversion or extension of knowledge for use in particular applications." However, although a reflective practice diary was not kept, it is argued that all conscious design activity comprises an element of reflective practice, albeit not in the formal sense. This differentiation between the ideal and actual processes is illustrated in the maps of the research design in 4.2, where the methodological approach is discussed in more detail.

Yin states that case studies are holistic and focus on real life events⁷¹, objectivity must be maintained by externalisation through peer review and client involvement, he considers the case study a 'comprehensive design strategy' and one which is appropriate to investigate:

“a contemporary phenomenon within its real life context, especially when the boundaries between phenomenon and context are not clearly evident”.

This can be seen to have relevance to design, where the creation of an artefact and its conditions of use are consistently interwoven.

It has been stated throughout the course of this study that the focus of study (i.e. the case studies) must seek at all times to represent design activity as it is carried out in commercial practice. The peer group (design team) must therefore operate as designers within the commercial marketplace. It is believed that any ‘experimental’ academic representation of this is unacceptable to the study as it will not and cannot have the same parameters that are applied in a real world situation. Stauffer & Ullman⁷² define three main methods of knowledge elicitation;

- 1. direct observation or contemporaneous study of real design tasks,*
- 2. retrospective reports and studies of past real design tasks,*
- 3. protocol analysis of simple experimental design tasks.*

In order to maintain maximum parity with real-life practice, the methodological rationale of the study is based on reflection on the execution of the design process. In the employment of technique ‘1’ it can be argued that ‘knowledge of observation’ might influence the activities being carried out. Nevertheless, a certain element of this technique must be employed if the practitioner is to ‘reflect-in-action’.

Technique ‘2’ appears to allow the design process to unfold naturally but requires the maintenance of a comprehensive narrative record in the form of case studies, diaries, anecdotal records etc. by the designer for analysis by someone else. Technique ‘3’, takes the design process even further from normality by placing it in an experimental setting. It is argued by the researcher that in the context of the research aim of this study, this technique is far removed from the fundamental premise upon which this research is based and therefore inappropriate for use.

Holness⁷³ states that: “*only a combination of techniques can elicit all types of knowledge used in the design process*”. It is expected that the use of case studies will provide the core of information necessary to do that. The use of case studies therefore encompasses elements of both techniques ‘1’ and ‘2’. Although ‘2’, described what was actually carried out in terms of reflection-on-practice, this was done not as a third party, but with the researcher as the central enquirer in the case studies. Within the case study there was a: ‘contemporaneous study of real design tasks’ as an implicit part of the design process, along with: ‘studies of past real design tasks’. Within the latter element there was an emphasis on the recall of past events, which Holness⁷⁴ describes as providing “*The motives and reasons for the respondents adoption of the activities they describe, the values held and influences used to form their motives and reasons*”. The emphasis on value judgements suggests therefore that the technique most appropriate was that which elicited data of a qualitative rather than quantitative nature, essentially reflecting the nature of the design process. Further, it is hoped that the use of multiple case studies will provide an element of ‘replication’. The intent was to reveal findings that can be presented as a generalised finding for industrial design consultancy practice.

3.4.3 Research objectives and relationship to action research

The objective of the research programme was to develop, through the completion of a number of case studies, a heuristic map representing the use of digital technologies, especially that of 3D CAD, as a communication tool within the design process. As has been previously stated, the researcher believes there to be a gap between the findings of observational research and the application of those findings to commercial design practice. The idea behind using the map to communicate research findings was to present findings in such a way that they are both meaningful and accessible to the practicing designer. The analogy of the ‘map’ was seen to be appropriate as it lays out, in a navigable form, the various routes to the design result through the utilisation of digital technologies.

The representation of case study findings in the form of a map externalises the findings of the study in order that they might be clarified or refuted by others. This was seen to be a critical part of the action research cycle, as defined by McNiff⁷⁵, where the focus of study is constantly refined as the research process develops. Although its affinity with Applied Research is acknowledged, the investigation undoubtedly incorporated elements of reflective practice (even though its case studies have not been reported as reflective practice accounts), reflection on practice, and reflection on reflection on practice, thus providing the insight that describes both implicit and explicit design actions.

In order to do this a research design must be devised. A research design is a plan that:

*"guides the investigator in the process of collecting, analysing, and interpreting observations. It is a logical model of proof that allows the researcher to draw inferences concerning casual relations among the variables under investigation. The research design also defines the domain of generalisability, that is, whether the obtained interpretations can be generalised to a larger population or to different situations"*⁷⁶

The conflict between design practice and research has already been acknowledged and for the time being there appears to be no optimum design research methodology. More recently however, Scrivener⁷⁷ has suggested an approach for closing down this conflict, through a design research method described as Research-in-Design. This approach utilises a designer's accumulated experience, accepts that the designer is central to the process, but proposes a systematic and public recording of actions, reflection on actions, and reflection on these reflections. This is a powerful proposal that enables the elevation of everyday design practice to that of a combined design and research practice, that doesn't correspond exactly to the accepted norms of either. However, such theories are relatively recent and the researcher accepts that the methodology chosen had the best fit for handling the research objectives, it draws on a range of techniques which are applied in as systematic a manner as possible.

Unlike the work of many previous design researchers, this study is not concerned with the act of designing itself, but merely with investigating the methods by which designs are communicated and how this affects the decision making process. At the outset of the project, the methodological approach was not fully defined. The development of the research programme has been an opportunity to refine the techniques and tactics of practice through the application of a partial action research methodology. The investigation has parity with an action research cycle defined by Whitehead⁷⁸ when he asked the question: 'How do I improve this process of *education* here?' His process can be adapted for design, asking the question: 'how do I improve this process of *design*?':

- I experience problems when my design methods are challenged in practice
- I imagine ways of overcoming my problems
- I act on a chosen solution
- I evaluate the outcomes of my actions
- I modify my problems, ideas and actions in the light of my evaluations

Utilising this approach for Action Research, the case studies are then reflected on to create a case study report. Analysing the report through a process of cross-case analysis⁷⁹ enables a series of statements to be made regarding the use of media and provides the information necessary for the creation of the heuristic map. Drawing from McNiff's⁸⁰ theory describing a generative process whereby a number of problems can be addressed at once without losing sight of the original focus and the enquiry can be entered into at any point, the map enables the designer to define their start point within the process, then explore the range of possibilities available from the context of that start point. This combination of Action Research methods within design projects and their use as case studies within an applied research setting based on a case study method in order to derive generic knowledge from them has been advocated by Young⁸¹.

-
- ¹ ALEXANDER, C. cited in Cross, N (Ed.) *Developments in Design Methodology*, Wiley, 1984, preface.
- ² ARCHER, B. A background to doctoral awards. International conference on doctoral education in design, La Clusaz, France, 8-12 July 2000. *Doctoral Education in Design: Foundations for the Future*. Proceedings, edited by D. Durling and K. Friedman. Staffordshire University Press, 2000, p. 257-260.
- ³ CROSS, N. *Developments in Design Methodology*, Wiley, Chichester, 1984.
- ⁴ BROADBENT, G. The development of design methods, in *Design methods and theories*, 13 (1), 1979, p. 41-45.
- ⁵ CROSS, N. Op. cit.
- ⁶ JONES, J. C. *A method of systematic design* in Cross, N. (ed.) *Developments in Design Methodology*, Wiley, 1984.
- ⁷ ALEXANDER, C. *The determination of components for an Indian village* in Cross, N. (ed.) *Developments in Design Methodology*, Wiley, Chichester, 1984.
- ⁸ ALEXANDER, C. *Notes on the synthesis of form*. Harvard University Press, 1964.
- ⁹ ARCHER, B. *Systematic method for designers*. The Design Council, London, 1965.
- ¹⁰ LUCKMAN, J. An approach to the management of design, in *Operational Research Quarterly*, 18 (4), 1967, p. 345-358.
- ¹¹ LUCKMAN, J. Ibid.
- ¹² LEVIN, P. H. Decision making in urban design, in *Building Research Station Note*, EN 51/66, 1966.
- ¹³ ALEXANDER, C. and POYNER, B. cited in Cross, N (Ed.) *Developments in Design Methodology*, Wiley, 1984, p. 100.
- ¹⁴ RITTEL, H. and WEBBER, M. *Planning problems are wicked problems*, in Cross, N. (ed.) *Developments in Design Methodology*, Wiley, Chichester, 1984.
- ¹⁵ SIMON, H. The structure of ill structured problems, in *Artificial Intelligence*, 4, 1973, p. 181-200.
- ¹⁶ LAWSON, B. Cognitive strategies in architectural design, in *Ergonomics*, 22 (1), 1979, p. 59-68.
- ¹⁷ DARKE, J. The primary generator and the design process, in *Design Studies*, 1 (1), 1979, p. 36-44.

-
- ¹⁸ KUHN, T. *The structure of scientific revolutions*. University of Chicago Press, 1962.
- ¹⁹ HILLIER, W., MUSGROVE, J. and SULLIVAN, P. 'Knowledge and design', in Mitchell, W. J. (ed.) *Environmental Design: Research and Practice*, University of California, 1972.
- ²⁰ AKIN, O. An exploration of the design process, in *Design Methods & Theories*, 13 (3/4), 1979, p. 115-119.
- ²¹ LAWSON, B. Op. cit.
- ²² THOMAS, J. and CARROLL, J. The psychological study of design, in *Design Studies*, 1 (1), 1979, p. 5-11.
- ²³ POPPER, KUHN and LAKATOS. cited in Cross, N (ed.) *Developments in Design Methodology*, Wiley, Chichester, 1984. p. 238.
- ²⁴ HILLIER, W., MUSGROVE, J. and SULLIVAN, P. Op. cit.
- ²⁵ DALEY, J. Design creativity and the understanding of objects, in *Design Studies*, 3 (3), 1982, p. 133-137.
- ²⁶ ALEXANDER, C. Op. cit.
- ²⁷ RITTEL, H. Second generation design methods, in *The DMG 5th Anniversary Report: Occasional Paper*, No. 1, 1972, p. 5-10.
- ²⁸ ARCHER, B. Whatever became of design methodology?, in *Design Studies*, 1 (1), 1979, p. 17-18.
- ²⁹ ARCHER, B. The Nature of Research, in *Co-Design Journal*, 01.02.03, 1995, p. 6-13.
- ³⁰ McNIFF, J. *Action Research – Principles & Practice*. MacMillan, London, 1988.
- ³¹ ARCHER, B. Op. cit.
- ³² POPPER, K. *Conjectures and Refutations: The Growth of Scientific Knowledge*. Harper & Row, New York, 1965.
- ³³ REICH, Y. Annotated bibliography on research methodologies, in *Artificial Intelligence for Engineering Design, Analysis & Manufacturing*, 8, 1994, p. 355-366.
- ³⁴ ARCHER, B. Op. cit.
- ³⁵ REICH, Y. Op. Cit.

-
- ³⁶ REICH, Y. Layered models of research methodologies, in *Artificial Intelligence for Engineering Design, Analysis & Manufacturing*, 8, 1994, p. 263-274. [Adapted from Smith, C. N. and Dainty, P. (eds.) *The management research handbook*, Routledge, London, 1991. and Reason, P. and Rowan, J. (eds.) *Human enquiry: a sourcebook of new paradigm research*, Wiley, New York, 1981.]
- ³⁷ ARCHER, B. Op. cit.
- ³⁸ McNIFF, J. Op. cit.
- ³⁹ REICH, Y. Op. cit.
- ⁴⁰ ARCHER, B. Op. cit.
- ⁴¹ McNIFF, J. Op. cit.
- ⁴² MCKERNAN, J. *Curriculum Action Research*. Kogan Page, London, 2nd Ed., 1996.
- ⁴³ MCKERNAN, J. Ibid.
- ⁴⁴ ARCHER, B. Op. cit.
- ⁴⁵ MCKERNAN, J. Op. cit.
- ⁴⁶ WHITEHEAD, J. Creating a living educational theory from questions of the kind, 'how do I improve my practice?', in *Cambridge Journal of Education*, Vol. 19, No.1, 1989.
- ⁴⁷ LEWIN, KEMMIS, ELLIOT & EBBUTT, cited in McNiff, J. *Action Research – Principles & Practice*. MacMillan, London, 1988.
- ⁴⁸ MCKERNAN, J. Op. cit.
- ⁴⁹ SCHON, D. *Educating the Reflective Practitioner*, Jossey Bass, 1991.
- ⁵⁰ WHITEHEAD, J. Op. cit.
- ⁵¹ SCHON, D. Op. cit.
- ⁵² RITTEL, H. and WEBBER, M. Op. cit.
- ⁵³ MCKERNAN, J. Op. cit.
- ⁵⁴ ARCHER, B. Op. cit.
- ⁵⁵ FRAYLING, C. *Research in Art and Design*, RCA Research Papers, Vol. 1, No. 1, 1993/94.
- ⁵⁶ SCHON, D. Op. cit.

-
- ⁵⁷ McNIFF, J. Op. cit.
- ⁵⁸ HALSEY, A. H. *Educational priority*, V1, HMSO, 1972.
- ⁵⁹ MARRIS, P., and REIN, M. *Dilemmas of social reform: poverty and community action in the United States*, Routledge, 2nd Ed., 1972.
- ⁶⁰ HALSEY, A. H. Op. cit.
- ⁶¹ MCKERNAN, J. Op. cit.
- ⁶² OSTERMAN, K. and KOTTKAMP, R. *Reflective practice for educators: improving schooling through professional development*. Corwin Press, 1993.
- ⁶³ SCHON, D. *Educating the Reflective Practitioner*, Jossey Bass, 1991, p. xii.
- ⁶⁴ LEWIN, K. cited in McNiff, J. *Action Research – Principles & Practice*. MacMillan, London, 1988.
- ⁶⁵ WHITEHEAD, J. Op. cit.
- ⁶⁶ McNIFF, J. Op. cit.
- ⁶⁷ MCKERNAN, J. Op. cit.
- ⁶⁸ SCHON, D. Op. cit.
- ⁶⁹ McNIFF, J. Op. cit.
- ⁷⁰ SCHON, D. Op. cit.
- ⁷¹ YIN, R. K. *Case study research, design & methods*, Sage, 1993 2nd Ed..
- ⁷² STAUFFER, L. A., and ULLMAN, D.G. A comparison of the results of empirical studies into the mechanical design process, in *Design Studies*, Vol. 9, No. 2, 1988, p. 107-114.
- ⁷³ HOLNESS, A. Current PhD programme at UNN, entitled *The analysis of design methods by a comparative study of award-winning industrial architecture since 1970*.
- ⁷⁴ HOLNESS, A. Ibid.
- ⁷⁵ McNIFF, J. Op. cit.
- ⁷⁶ NACHMAIS, D., and NACHMAIS, C. *Research methods in the social sciences*. New York: St Martin. 1992.
- ⁷⁷ SCRIVENER, S. Towards the operationalisation of design research as reflection in and on action and practice. International conference on doctoral education in design,

La Clusaz, France, 8-12 July 2000. *Doctoral Education in Design: Foundations for the Future*. Proceedings, edited by D. Durling and K. Friedman. Staffordshire University Press, 2000, p. 387-394.

⁷⁸ WHITEHEAD, J. Op. cit.

⁷⁹ YIN, R. K. Op. cit.

⁸⁰ McNIFF, J. Op. cit.

⁸¹ YOUNG, R. A. *Developments in the theory and practice of reflective design practice*, in Useful and Critical, International Conference on Art and Design, Helsinki, Finland, 1999.

Chapter 4: Case Studies & Analysis

“There are no design theories worth much attention and no figures of the status of Freud, Jung, Galbraith, or Marx to give a supervening perspective. So, without a consensual theory, or leading figures, all we have is a ragbag of ideas about a variety of practices. This means that empirical case study is the only way forward that has any real credibility.”

WALKER, D. The case for cases, Co-Design Journal, 01.02 03, 1995, p.33

4.0 CASE STUDIES & CASE STUDY ANALYSIS

4.1 Introduction

This chapter describes the main investigative body of work underpinning this research programme: the case studies and case study analysis. The case studies were undertaken as a vehicle to facilitate the understanding of the different tools that designers employ for design development and communication within the design process. The information provided by the case studies is captured in a full case study report (Appendix 2.2, 2.3, 2.4 & CD) and in the creation of a series of case study indexes. These indexes capture all the incidences of media use within each of the case studies, providing an accurate, chronological account of each project, and can be viewed on the accompanying CD.

Following the description of the case studies is an explanation of the case study analysis process, where the case study indexes are overlaid to create a series of cross-case analysis maps. The findings revealed through the creation of these maps provide the material enabling the creation of an integrated cross-case analysis map; this provides a reference for citations of media use throughout all the case studies and enables the derivation of the final Heuristic Map.

4.1.1 The case studies

Case studies are a key investigative technique used in medicine, law and education for the development and improvement of practice. Case studies can be described as ‘an attempt to capture reality’¹, and it is with precisely this objective that case studies provide the investigative basis for this thesis. Through the active participation of the researcher as an active member of the design team, the intention is to reveal what actually happens within certain aspects of the design process, rather than relying on what is thought to happen.

The investigation is based on three main case studies, with other projects carried out within the Centre, and the case studies from the formative research phase also informing the research. The case studies had to conform to a number of criteria before being considered for inclusion in the programme:

- The projects must be 'live', projects, which are to be carried out for an external client on a fee-paying basis.
- The client had to agree on the inclusion of the project into the research programme.
- The projects should have the strong likelihood of 3D CAD being used as an integral part of the process - 3D CAD should not be used solely to make the project fit the criteria.
- The project should span at least two, but preferably more stages of the design process.
- The project should be fully rounded, incorporating both functional and aesthetic considerations.

As the investigation eventually focused on only three cases, in hindsight it may have been appropriate to have relaxed the criteria to allow the study of other projects. The difficulty with a 'live' project as opposed to an experimental one is that the project path cannot be known at the outset. Some projects that were considered for study terminated before they had complied with the criteria for inclusion, others in hindsight complied with the criteria, but were not considered for study at the outset. The difficulty with this method is that it is ad hoc. If the research were undertaken again, the criteria for the selection of potential cases would be modified to include some form of prediction element, where a wider range of potential projects might be considered, with rejection of the unsuitable taking place at a later stage, this was not contemplated at the time. However, it can be seen that this is part of the action research process, with the development and improvement of research practice as important as that of professional practice².

The three case studies are summarised in this chapter, a full description of the events within each, as well as the accompanying case study index, can be found in Appendix 2. All three cases are in the medical field, as the majority of projects carried out within the Centre for Industrial Design had a medical bias. The first case study follows the design of a piece of medical packaging, incorporating a remote, automatic mixing process. The second describes the creation of a throat spray, incorporating a series of value engineering issues. The third and final case study concerned the design of a public access terminal providing access to personal medical records.

Although each case study concerned medically related products, this was not regarded as problematic due to the fundamental differences between them in terms of issues such as scale, user interaction and context. The throat spray is a small hand held device, bought and used by consumers; the mixing device is medium sized and would be used only by hospital staff, it would be purchased via a catalogue and discarded immediately following use; the public access terminal is large, and designed for access to private information in public spaces. These key differences mean that the design considerations for each product were substantially different.

Where the researcher is involved as a practitioner in all of the case study projects, the execution of projects within a research framework is not without its problems. In order not to interfere with the natural flow of practice, but in order to sustain some element (albeit unrecorded) of reflective practice, reflection on practice could only be carried out between stages of design activity, utilising material gathered during the process and reflecting on it after the event. This had implications for the period of the cycle of Action Research. The full cycle and its formal record was completed and recorded at the end of each stage of activity. The reflective elements between stages were not overt and were not formally recorded. Despite this, with the timeframe of some of the projects spanning more than a year, the amount of information gathered was significant. The creation of a corresponding case study index (fully explained in 4.3) was time consuming and potentially outside the time constraints of most

practitioners. It does however; provide a non-intrusive method of recording events and activities.

With so few research methods devised *specifically* for design research³, part of the research investigation has involved the development of a methodology for the execution and subsequent analysis of the case studies. The methodology devised has therefore been drawn from a number of sources including education and the social sciences, as well as the study of design itself.

4.2 Methodology

*“The essence of a case study, the central tendency among all types of case study, is that it tries to illuminate a decision or set of decisions: why they were taken, how they were implemented, and with what result.”*⁴

A full description of the rationale behind carrying out case studies within an adapted action research framework was described in Chapter 3, however it is helpful to look in more detail at how these methodologies relate to the actual process. The following diagrams illustrate firstly the ideal application of action research methods to the research programme followed by the actual application. Both describe how the elements of action research can be integrated with the execution of design case studies and then followed through to case study analysis.

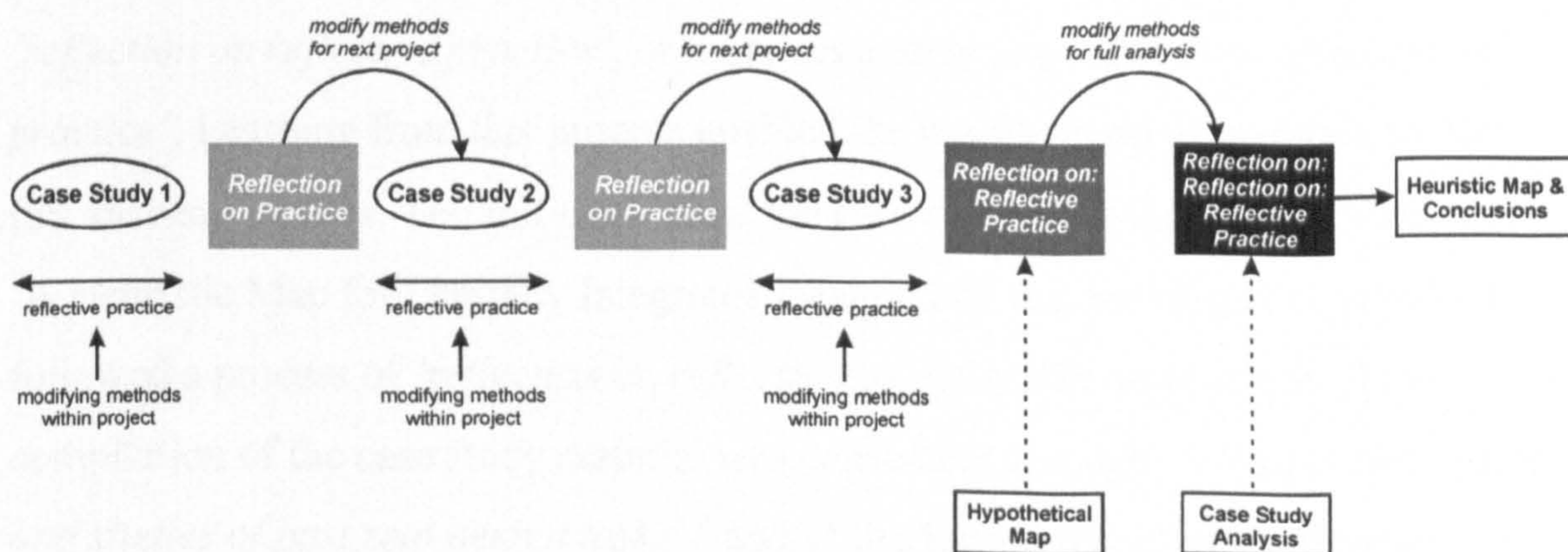

Fig. 4. The ideal application of an Action Research methodology to the research programme.

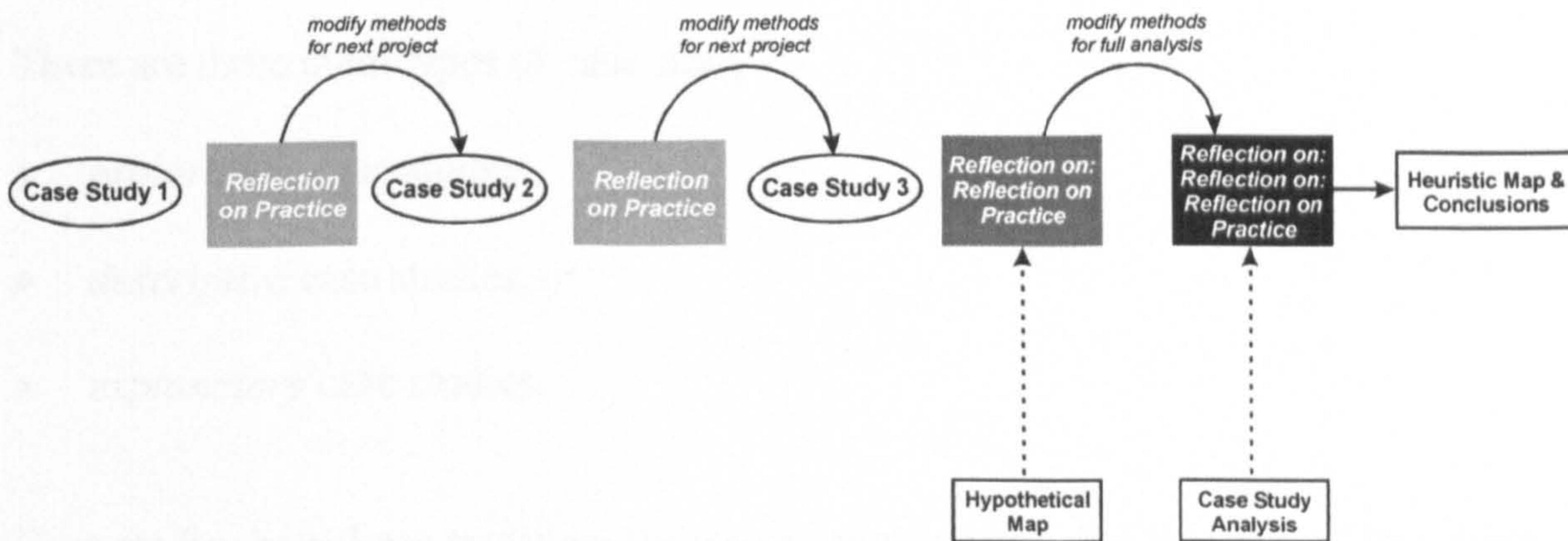

Fig. 5. The actual application of a partial Action Research methodology to the research programme.

As can be seen from comparing Fig. 4 and Fig. 5, although as has been previously stated the activity within the case studies did not followed a true process of *'reflective practice'*, methods for the execution of the process were modified between stages of activity within the design process, therefore it is argued that an unrecorded element of reflective practice took place, although this cannot be substantiated. *'Reflection on practice'* was carried out following each of the case studies. The learning from the experience of the previous project (case study), served to help the design team modify methods ready for the next. The analysis of the case studies was initially carried out through the creation of an initial hypothetical integration model. This represents an initial manifestation of the heuristic map based on general reflection of the case studies, which can be seen the outcome of a form of *'reflection on reflective practice'*, or more accurately, *'reflection on reflection on practice'*. Learning from this process enabled the modification of methods for the full analysis process. The full analysis of the case studies leading to the creation of *'A Heuristic Map for Digitally Integrated Design'* and the drawing of conclusions followed a process of *'reflection on reflection on reflection on practice'*. The compilation of the case study material was carried out through *'retrospective reports and studies of past real design tasks'*⁵ and as the formal record of the design projects; this transforms the nature of the research design for the study to that more in keeping with the premise of Applied Research projects based on case study data.

4.2.1 Types of Case Study

There are three main types of case study⁶;

- *exploratory* case studies,
- *descriptive* case studies, or
- *explanatory* case studies.

Case studies have been traditionally seen as *exploratory*⁷, but it is argued that these descriptors are not always distinctive and there is often significant blurring between the boundaries of each type of study⁸. Here, the approach is not to make a concise definition, but to make sure that it is the most appropriate under the circumstances, with the relevant case study technique dependent on certain conditions⁹;

- the nature of the research question,
- the control that the investigator has over events, and
- the level of historical or contemporary focus.

The nature of the research question: 'what do designers need to know?' suggests an element of *exploration* might be required. This can be seen to have happened during the formative research phase, where initial case studies and investigation revealed a number of propositions related to the use of digital modelling within industrial design. The questions for the latter case studies however, were more of a '*how*' and '*why*' nature, 'how did the designer communicate?' and why did he/she do it in this way? This, connected with the chronological linking of activities and events within a design project, suggest the use of *explanatory* case studies. As a reflective practitioner, the researcher had significant control over events; the adoption of an action research methodology requires action, intervention and change. The study can be seen to have adopted elements of both the *exploratory* and the *explanatory* case study approaches.

The case studies can be seen as a form of naturalistic field research and the process of carrying out the case studies conforms to Archer's¹⁰ requirements for carrying out '*research through the medium of practice*';

- *the practitioner activity was an enquiry whose goal was knowledge,*
- *it was systematically conducted,*
- *the data are explicit,*
- *the record of the conduct of activity is explicit,*
- *the data and the outcome are validated in appropriate ways.*

Although the case studies themselves are not replicable, the method and process underpinning them is. The data and the outcomes have been validated through a process of sharing with peers and other researchers and practitioners, both informally and formally through seminars, refereed papers and conference papers. The aim of this sharing with peers was to maintain objectivity and prevent the knowledge from becoming too subjective.

It was anticipated that the use of multiple case studies, combined with knowledge from other projects, would provide enough information with respect to the consistency of events to be able to create a map explaining the integration of digital with traditional communication techniques within the industrial design process. This was intended to provide an element of 'replication logic' as described by Yin¹¹ where:

"the development of consistent findings over multiple cases and even multiple studies, can then be considered a very robust finding".

4.3 Case Study Compilation

The case studies form the fundamental basis from which all the research findings were derived, therefore the method by which they were both carried out and reported

is of prime importance to the thesis. Although it is accepted that the participatory nature of the investigation means that the data revealed could never be totally objective¹², by their very nature action research methods refer constantly to the input of peers as part of the cyclical learning process, referred to as a ‘virtuous cycle’ by McNiff¹³. In the case of this research project the peer review was not only internal, i.e. that which was carried out by my colleagues, both in the context of their design practice in the case study projects as well as in the compilation of material, but external, through the practitioner/client relationship.

The evidence pertaining to each of the case studies is contained within what is described as a case study ‘index’. This ‘index’ references all relevant events within each of the case studies and provides the protocol template within which each of the case studies is compiled. The case study evidence comprises four principal sections:

1. *Section 1: Documentary evidence*
2. *Section 2: Visual Evidence*
3. *Section 2: Index*
4. *Section 3: Narrative*

4.3.1 Section 1: Documentary evidence

This section houses all of the documentary evidence collected throughout the course of each design project to which the case study relates. The documentary evidence (DE) relates to all project documents as well as referencing a number of telephone calls and face to face meetings. The written documents, such as faxes and letters, are contained in a series of project files, the majority of the documents are comprised of words, but some of the documents also contain visual information. However, as the visual information is contained within a *document*, it is referenced via the DE section. Each event to which each piece of evidence refers is recorded in the index; the original files remain the property of each client.

The DE is categorised into a number of sections, each piece of evidence is referenced by the index against one or more of these sections, enabling an investigator to cross reference to the original document to which the index refers. All documents relevant to the project are included, and are classified chronologically under a number of section titles*, e.g.:

- I. Project briefs, quotes & schedules*
- II. Design reviews & general reports*
- III. Correspondence to/from client*
- IV. Correspondence to/from third parties*
- V. Supplier selection/visit documentation*
- VI. Supplier quotations*
- VII. Confidentiality agreements*
- VIII. IPR information*

App1. General company information

App 2. Misc. items not dated

4.3.2 Section 2: Visual Evidence

This section houses all of the Visual Evidence (VE) collected throughout the course of each design project to which the case study relates. The evidence, presented on the accompanying CD, corresponds with the associated contents list entry and is organised in a chronological manner. The full text of the case study narrative can be found in Appendix 2 and is summarised in 4.4.1, 4.4.2 and 4.4.3.

* These titles relate specifically to the Bi-Liquid Mixing System case study. Not all of the case studies require the use of all these sections.



4.3.3 Section 3: Index

The index acts as the backbone of the case study, providing references for all the information available for each project. Each piece of DE is logged, referenced and categorised under a number of headings. Within the terms of the following explanation each item of DE or VE relates to an ‘activity’ within the design process. The index headings are defined as follows:

- Design Stage
- Importance
- Date
- Activity
- Source
- Media Type

Fig. 6 shows an example of a section of the project index. The indexes for each of the three case studies can be found on the CD.

Design Process	Importance	Year	Month	Date	Activity	Source	Media Type
Pre-Design Discussions	1	1993	May	19	CID send speculative letter to JJML	DE3	
	3			25	JJML confirm 1st meet date & send conf. agree.	DE3	
	4		June	3	Initial meet with JJML at Centre	DE1.	SD
	4		July	12	Quotation & project plan sent to JJML	DE1	
Concept Generation Stage Start	1			19	JJML query ownership of IP	DE1	
	1			20	Confirmation that IP owned by JJML	DE1	
	5			21	Brainstorm session	CD	SD
	1			23	Research evaluation carried out & questions sent to JJML	DE2	
	4			28	Received part answers to research evaluation & original design brief received by CFID	DE1	
	3		Aug	3	Further answers to research evaluation received	DE3	
	0			3	Audus Noble sign confidentiality agreement with CID	DE7	
	0			6	LMG sign confidentiality agreement with CID	DE7	
	0			18	Consultancy contract sent by UBS to JJML	DE1	
	5			20	Interim Presentation (initial concepts)	DE2. CD	SD. PI. M#2. CV.

Fig. 6. A section of the Mixing System case study index

4.3.3.1. Design Stage

This heading refers to the discrete stage in the design process that the activity was carried out, i.e. *Concept Generation*. This column refers to each stage as defined in the quotation and scheduling for the project. Most commercial projects carried out within the CfID followed a similar set of stages, where each stage would have quoted against it an amount of time and an estimate of cost. These stages are relevant to the case study in that they tend to define the major presentation or external communication points within the project. In hindsight it can be seen that most design projects follow a series of design iterations, eventually leading to a final solution. These can be seen as one of the cyclical elements within the process, where a significant amount of ‘skipping’ and ‘recycling’ takes place¹⁴.

4.3.3.2. Importance

This heading refers to the importance of the activity to the development of the design. Classified on a scale from 0-5, the level of ‘importance’ refers to the relevance of each activity in terms of its influence on the project. A qualitative judgement made by the researcher as an active participant in both the research and design processes, the rating gives an indication of how important each activity was to decision making and therefore to the general progress of the design project. Ranging from 0 = of minimal importance, to 5 = of prime importance, this initial classification is key in that it serves to identify the most important elements of activity within each project. Activities given an importance classification of '5' are shown in bold. Activities that have been given a zero rating may have made some contribution to the development of the project, but would tend to be concerned with the administrative, rather than the design aspects of the work.

4.3.3.3. Year/Month/Day

This heading refers to the date that the activity was carried out. These columns identify the year, month and exact date of each activity as referenced by the documentary evidence. All activities are ordered chronologically.

4.3.3.4. Activity

This heading comprises a short description of the activity or activities to which the documentary evidence refers, i.e. *Presentation of Initial Concepts*.

4.3.3.5. Source

This identifies where within the files of documentary evidence the reference to this activity can be found, and is referenced according to the sections described in 4.3.1.

If an activity is referenced twice, both are stated. If the activity described is supported by some visual evidence available on the CD, this is also stated.



4.3.3.6. Media Type / Definitions

Essentially representing the taxonomy of the media, this shows what media types were used to support the activity, identifying the forms of communication or media types that were used within each activity. All forms of visual communication have been categorised as 2D or 3D, digital or non-digital forms of communication. All relevant activities can then be reasonably assumed to fall into a number of classifications made under these four headings. Definitions and illustrations of these media types can be found on the CD.



4.3.4 Section 3: Narrative

This section is what can be described as the ‘flesh’ of the case study. It provides a commentary on the events that occurred throughout the project and describes how and why the various forms of communication were employed and what effect it had on the development of the project.

Section 4.4 provides a summary which is illustrated by a selection of visual evidence images, the full set of images can be viewed on the accompanying CD.

4.4 The Case Studies

The following section provides a brief overview of the three case studies, which provide the core investigative material for the thesis.



4.4.1 Case Study 1. Bi-Liquid Mixing System

Client: *Major Pharmaceutical*
Product: *Bi-Liquid Mixing System*
Project: *The design of a bi-liquid mixing vessel for use with a new sterilising solution*

The following provides a brief summary of the key events that occurred during the execution of a project to develop a Bi-liquid mixing system for a new type of endoscope cleaner. The Centre for Industrial Design carried out this project between May 19th 1993 and August 24th 1995. A full report for this case study can be found in Appendix 2.2, a full visual record of this case study can be accessed via the CD.

4.4.1.1. The Brief

Design a method of packaging two liquids, an acid and a buffering solution which, when combined, provide a sterilising solution for endoscopes. The liquids must be kept separate until the solution is ready to be used and the user should have no access to the liquids until they are mixed. The container must be tamper evident and pouring the resultant mixed solution should take less than 20 seconds with no undue splashing.

4.4.1.2. The Result

The final product consisted of six components, making up an inner flask and an outer container. The inner flask comprised a lower component, into which the acid would be poured, then an upper component to cap it off. This would be inserted into the neck of the main bottle, previously filled with a buffering solution, and held via a mechanism in the neck of the bottle. An over cap completed the container, tripping over a set of ratchets on the top of the acid flask.

On removal of the over cap the ratchets activate, unscrewing the cap of the inner flask, releasing it's contents into the solution below. By the time the user has removed the over cap, the acid is neutralised and the resulting solution can be poured through the annular space between the top cap of the inner flask and the neck of the container. To the user this complex set of events would not be apparent, as far as they were concerned, all they had to do would be to screw the cap off and pour the solution out, a standard activity requiring no instruction or training.

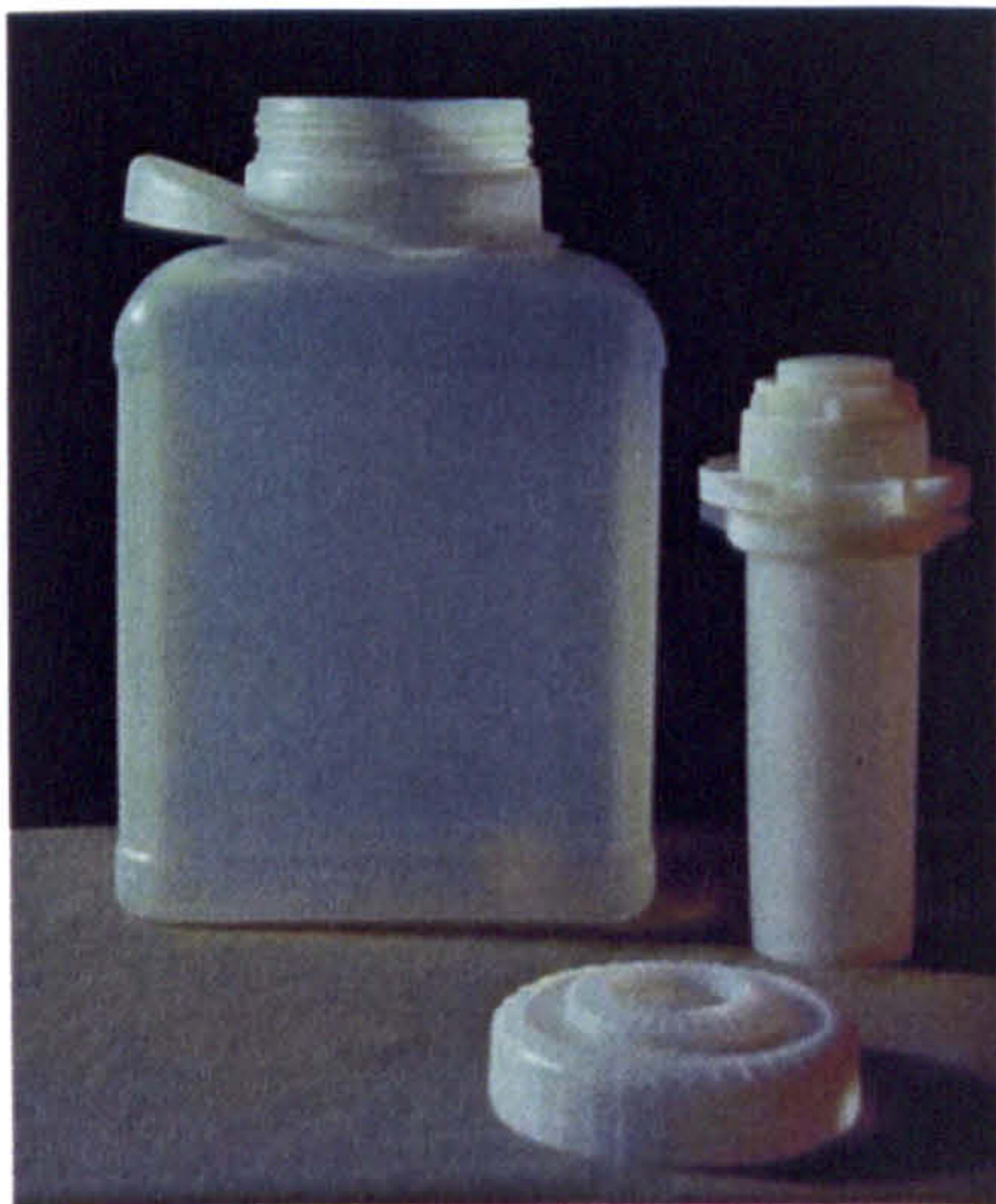

Fig. 7. Final mouldings – mixing system

4.4.1.3. The Process

During the course of this project, 3D modellers (both constrained and unconstrained) comprise the predominant design tool. This is principally due to two reasons; firstly in most instances the nature of the design with its complex cause and effect interactions demanded it; secondly it can be seen that its use was a means of impressing the client. In hindsight there are some incidences of its use within the project that are in excess of the requirements of the project, such as in the first ‘initial concepts’ presentation (Fig. 8). However, it can also be seen that in the earlier stages of the project the use of 3D computing gave the client the confidence that concepts worth pursuing had been generated (Fig. 9), and in the latter stages it was imperative to the proving of the design through the use of rapid prototyping (Fig. 11). The use of 3D computing also enabled our client to communicate the design of the product independently, with outputs such as a 3D animation forming a complete communication piece, requiring little or no interpretation (Fig. 12). At the time that

this project was carried out few toolmakers could accept 3D data, so although we were able to generate 2D specifications directly from the 3D models there was still a certain amount of interpretation that had to be done on their part. However, it is true to say that having the ability in the earlier stages to supply what was essentially a photograph of the finished component, and in the latter stages a physical model, removed a considerable amount of this interpretation (Fig. 11). In fairness, without the use of 3D computing, neither the Centre for Industrial Design nor the client would have had the confidence to pursue the concepts to tooling, and if we had, it can be assumed that the amount of tooling modifications required would have been far more extensive, leading to increased delays and project expenditure.

The project did not utilise any of the more aesthetically driven tools such as soft modelling or appearance models, this was primarily due to the functional nature of the project, with the complexity of the components making such approaches inappropriate. Fig. 8 to Fig. 12 provide a selected visual summary of the project, the full visual summary can be viewed on the CD.

Fig. 8. Mixing system: Initial Concepts

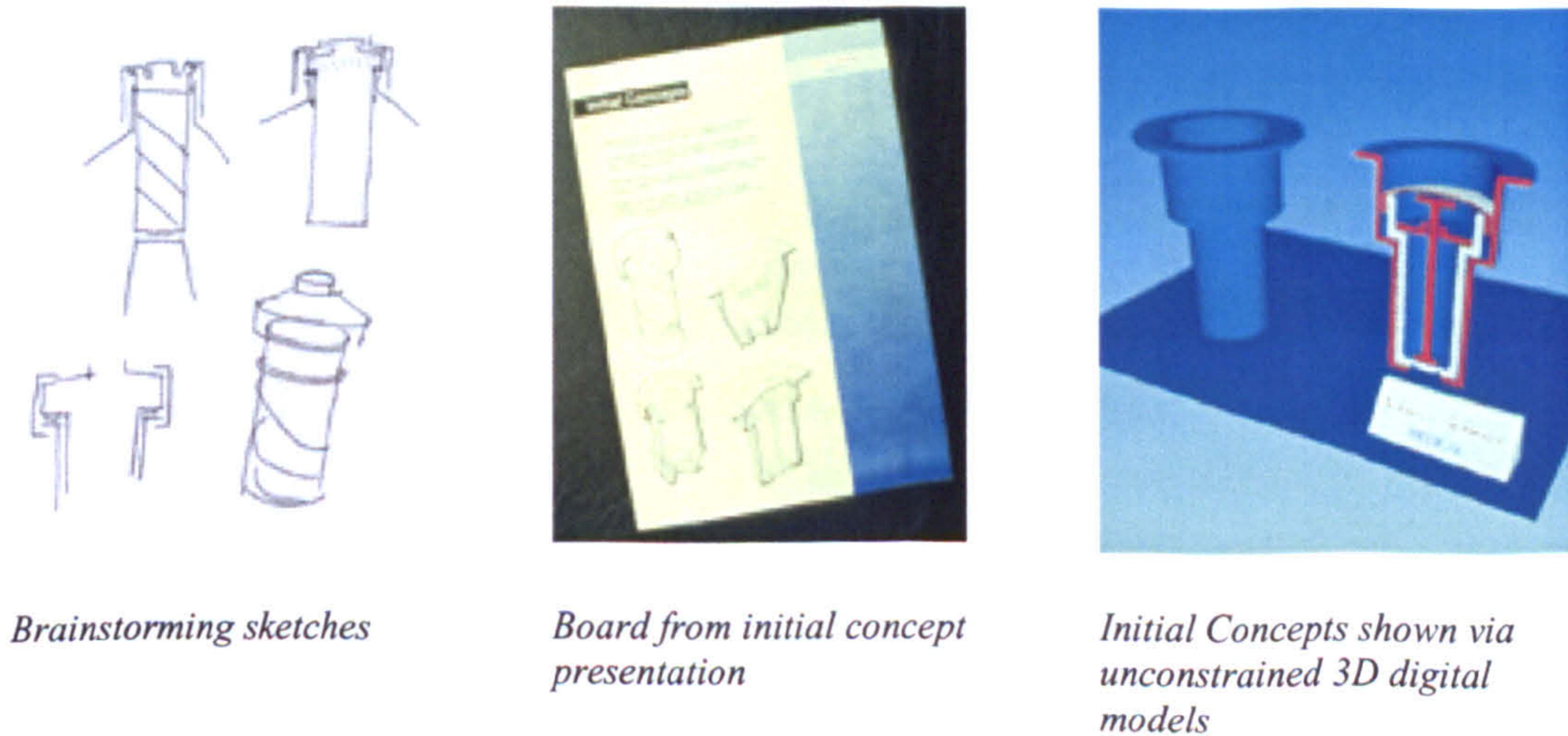

Brainstorming sketches

Board from initial concept presentation

Initial Concepts shown via unconstrained 3D digital models

Fig. 9. Mixing system: Design Development A

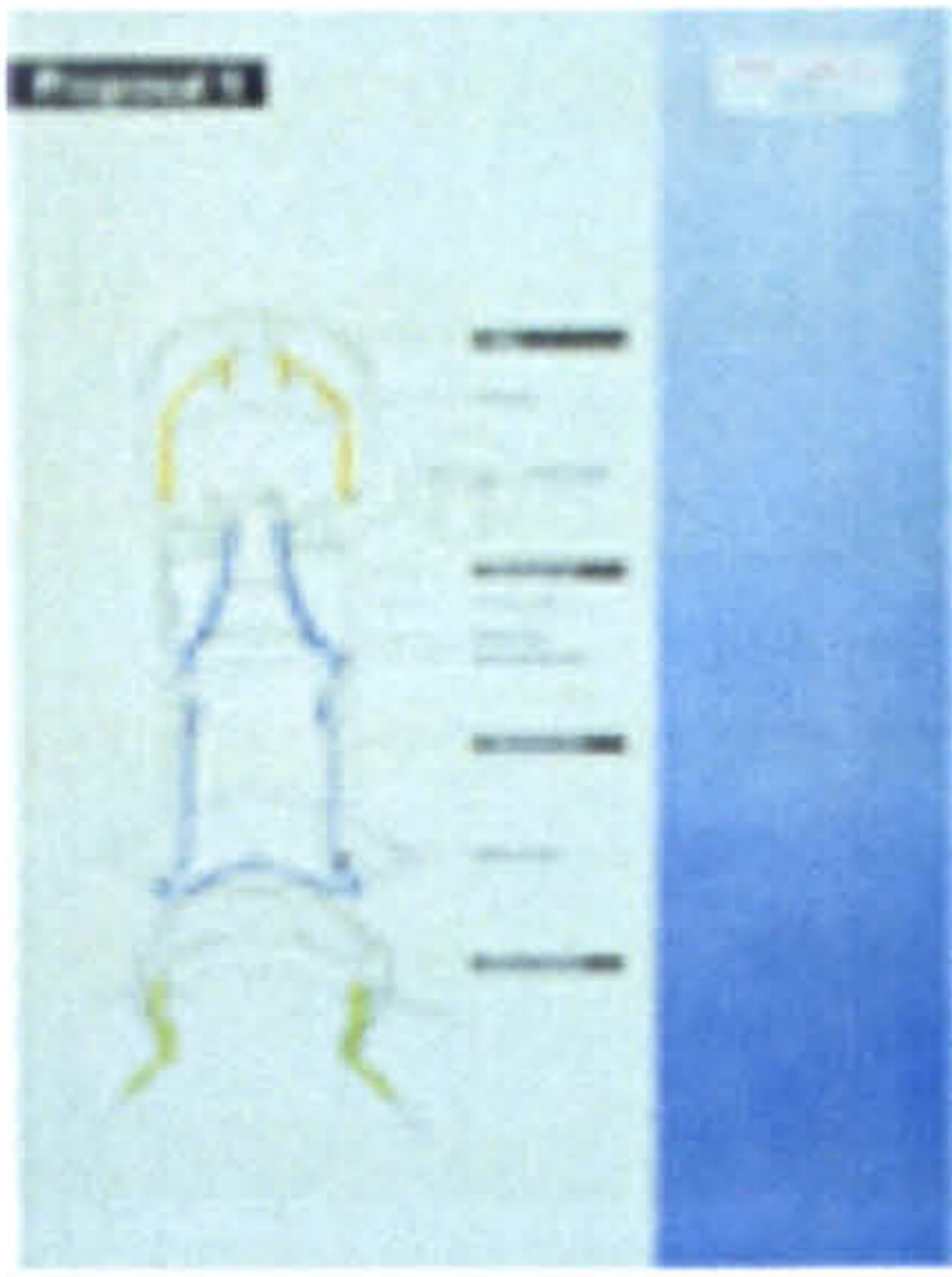

Presentation Illustration showing x-sectional view

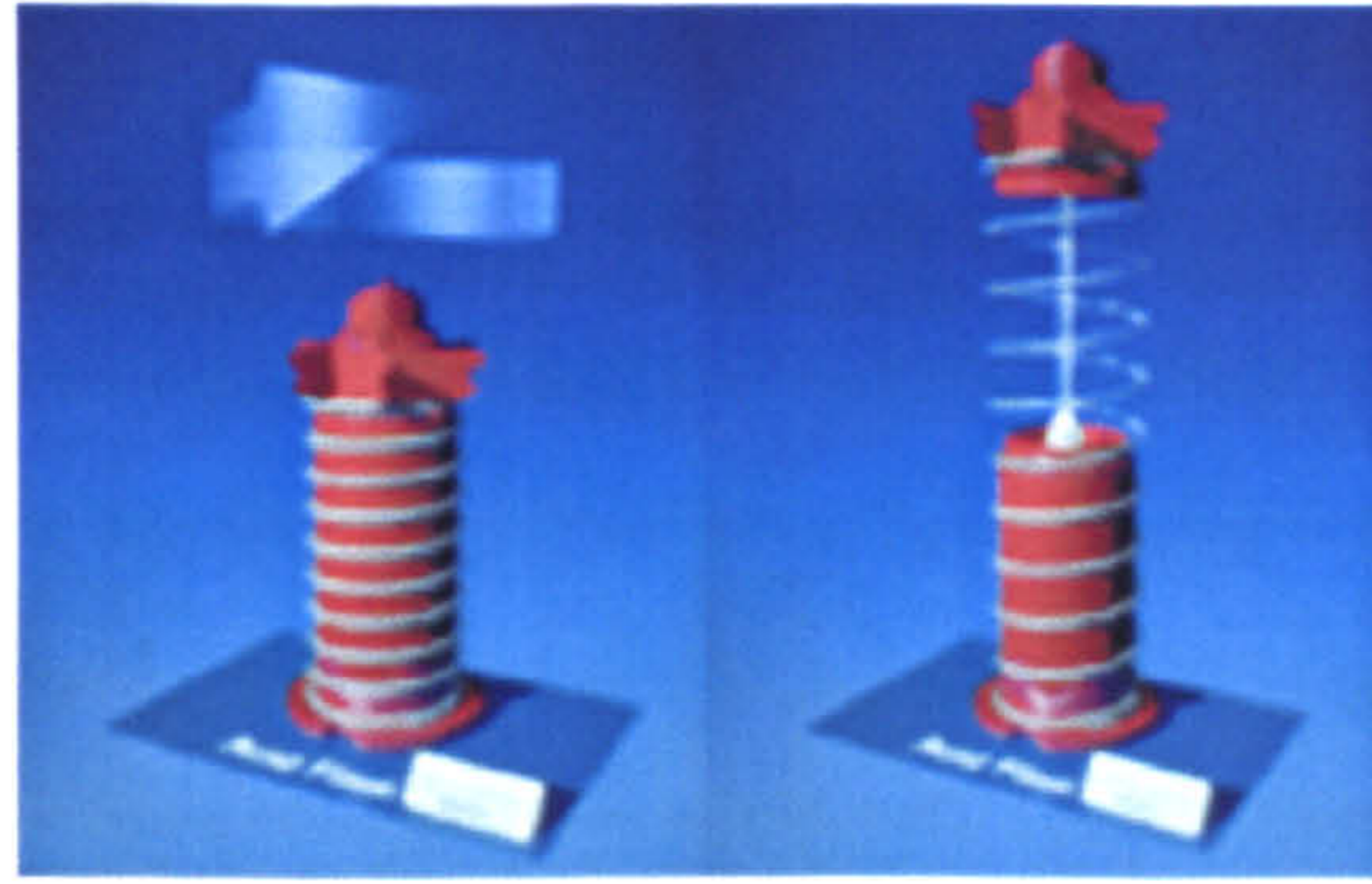

The 3D unconstrained model created to develop the principles of the concept is also ideal to communicate to the client

Fig. 10. Mixing system: Design Development B

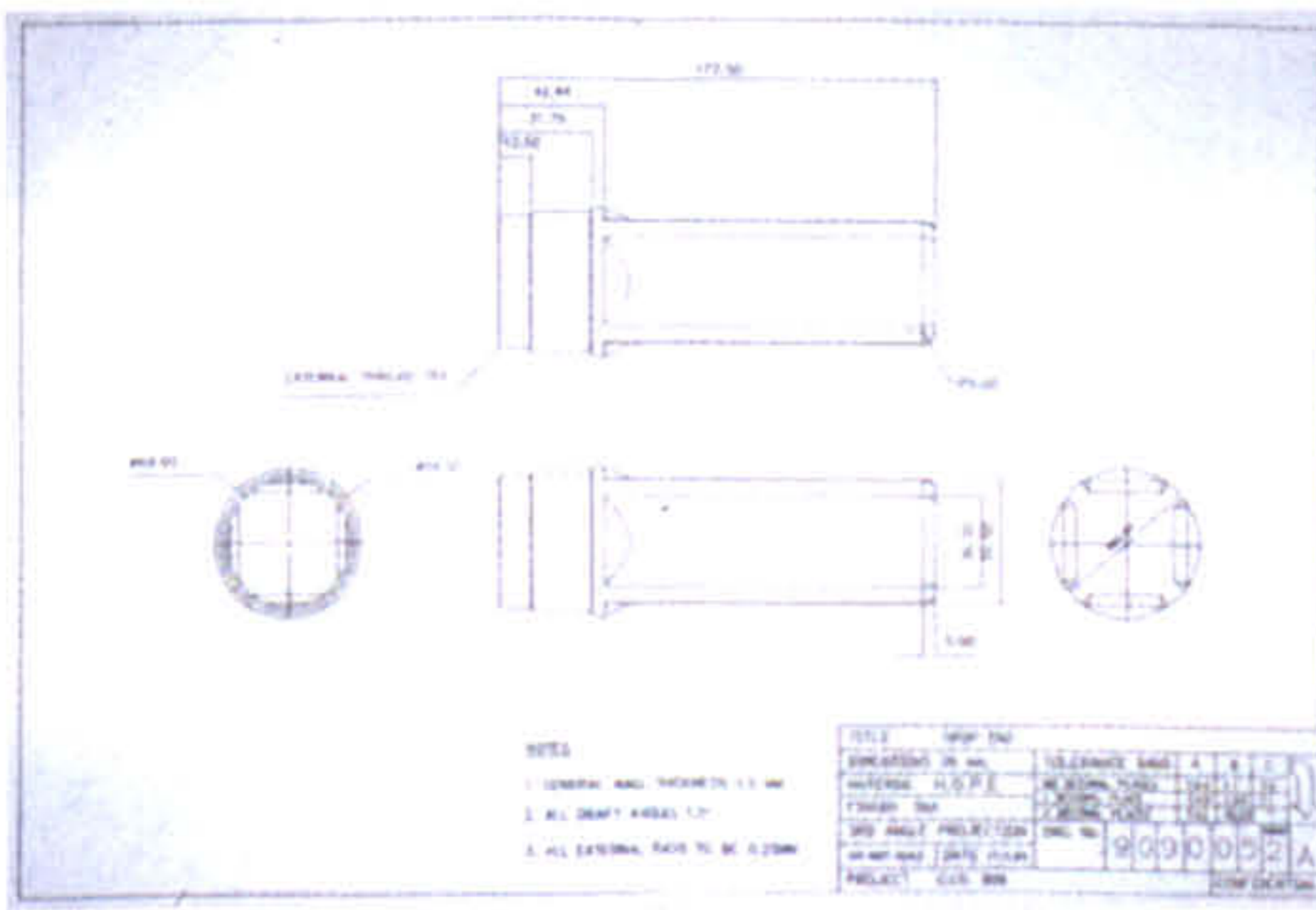

Typical example of a 2D technical drawing sent out for quotes



Development of the concept was moved to a constrained 3D modeller – Pro Engineer



A short animation was created in order to explain the concept to the client

Fig. 11. Mixing system: Design Development C: Final Specification

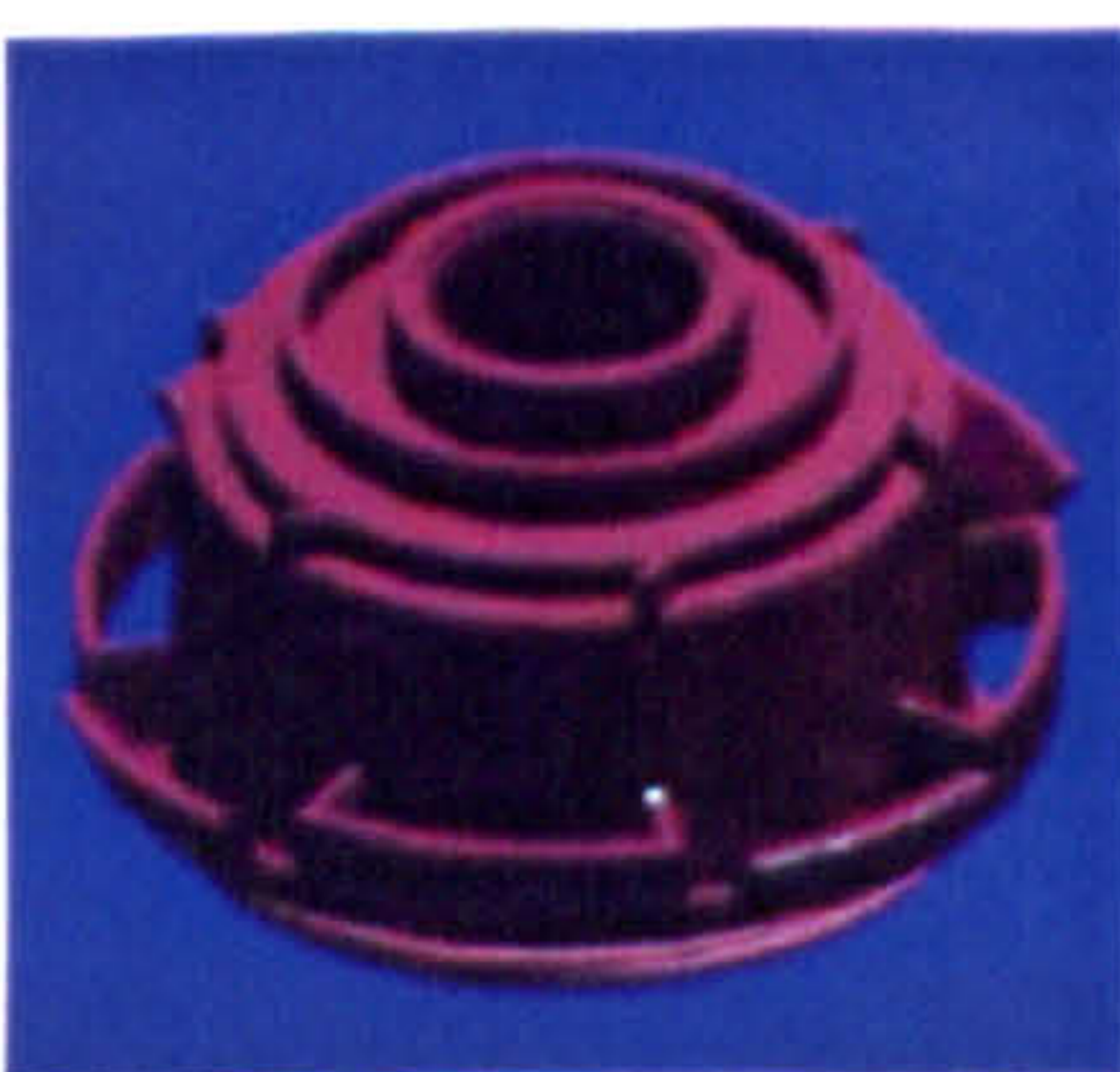

3D Digital component



Rapid prototype created directly from 3D Data

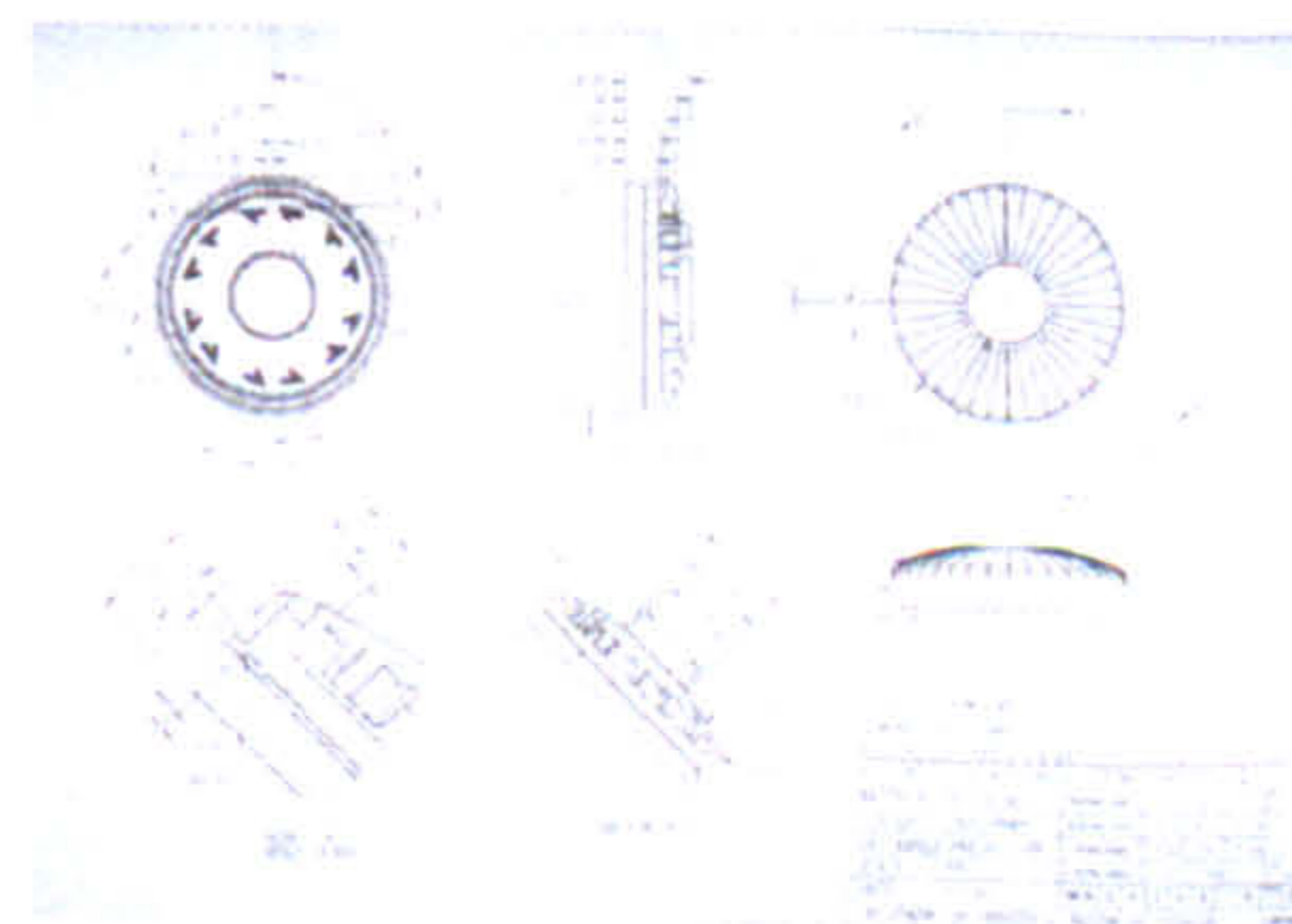

Technical Drawing created directly from 3D Data

Fig. 12. Mixing system: Communicating the design to external parties

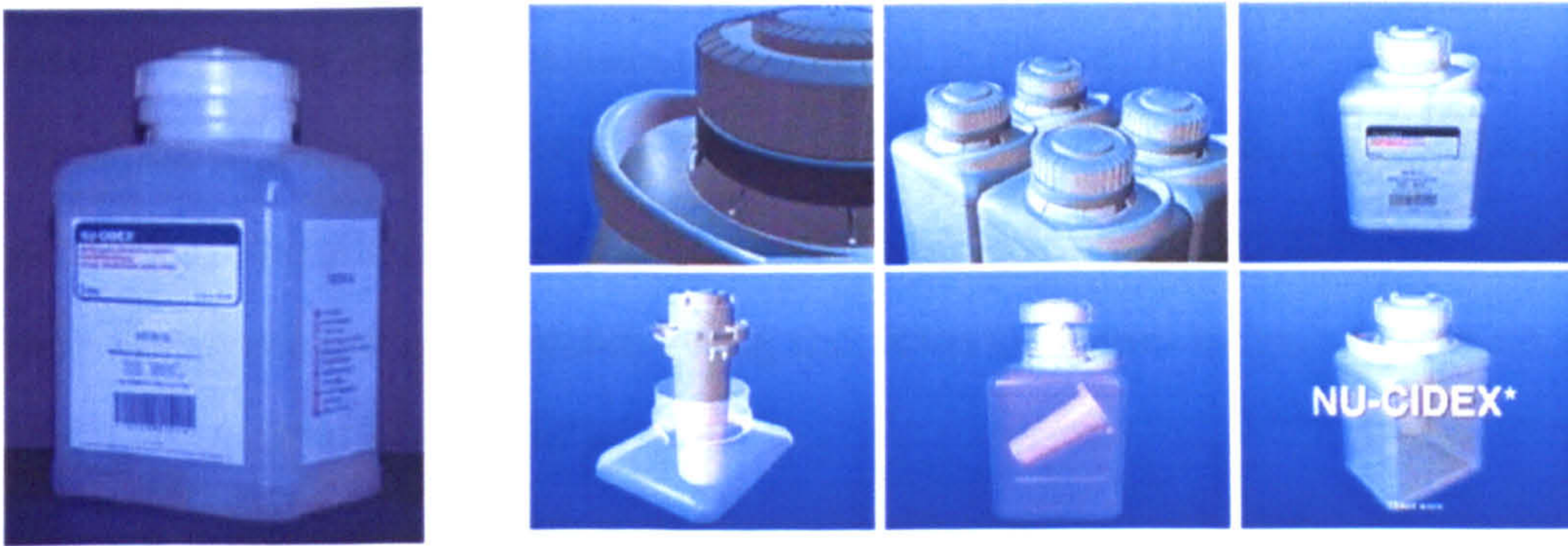

Some plastic parts and some rapid prototype parts were used to present the physical aspects of the design

3D animation used to display the concept to a large audience

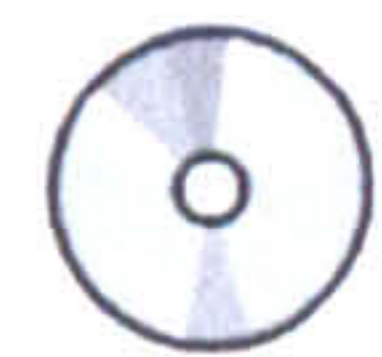

4.4.2 Case Study 2. Soulagil

Client: *Procter & Gamble*

Product: *Soulagil*

Project *The re-design of a packaging solution for a throat spray that would retain all the benefits of the existing pack whilst cutting costs by 30%.*

There follows a summary or overview of the events that occurred during the execution of the project named ‘Soulagil’. The Centre for Industrial Design carried out the project on behalf of Procter & Gamble (P&G) between February 18th and October 21st 1992.

4.4.2.1. The Brief

Re-design the packaging of an existing throat spray product (Soulagil/Ultra Chloraseptic). The existing packaging had a number of functional and ergonomic benefits, but was extremely expensive to produce. The challenge was to achieve a 30% cost reduction whilst maintaining the key benefits of the existing pack. These key benefits included the protection of the actuator when not in use, the prevention of UV deterioration of the Soulagil liquid, and the provision of a user-friendly method of application for the end user.

4.4.2.2. The Result

The existing product consisted of a custom produced bottle with an off centre neck sheathed in a label protecting the liquid from UV deterioration. The bottle was capped off with an over-cap within which sat a long armed actuator. Once the cap was removed, the user would swing the actuator round to gain better access to the application area (the throat).

The final design (Fig. 13) consisted of a bottle with an over-cap, which both managed and contained the long arm actuator. The actuator would be stored down the side of the product when not in use; the user would then remove the actuator and attach it to the pump in order to dispense the liquid. Once dispensed, the user would replace the actuator in the storage position. Replacing the existing custom bottle with a standard off the shelf component, the new bottle was coloured so the sheathing could be replaced with an inexpensive label. The large over-cap was replaced with a smaller one, which reduced material costs. The overall package was smaller & lighter thus reducing distribution costs. The new actuator required a modification of the existing tool, reducing the need for expensive re-tooling. The final design ultimately resulted in a production cost saving of 25% whilst maintaining the key benefits of the existing pack.

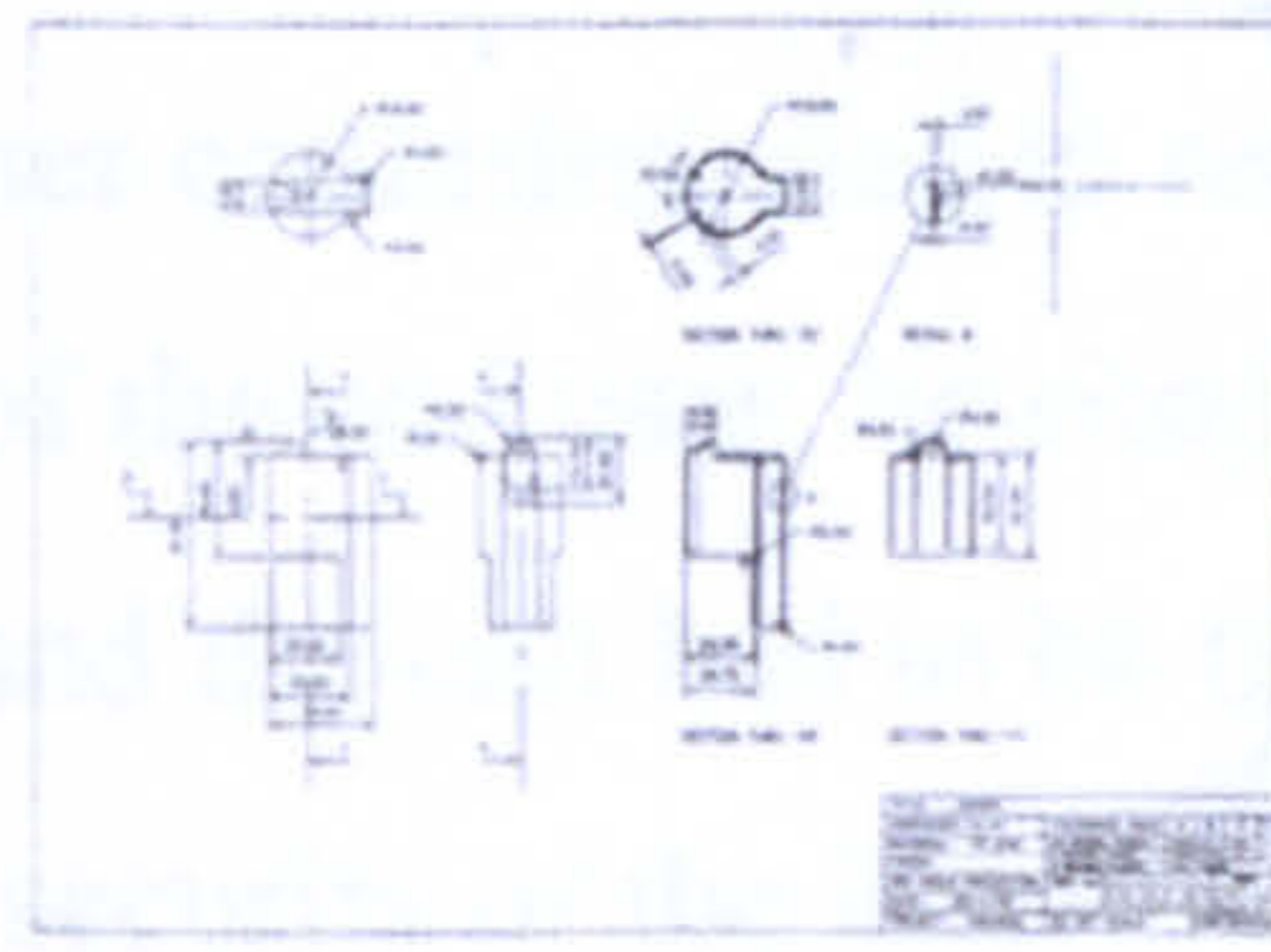

Fig. 13. Soulagil: Computer Visualisation of the final design

4.4.2.3. The Process

Reflecting on the process it can be seen that during this project computer visualisation is used to great effect but it is used predominantly as a communicator and a facilitator for making decisions, rather than as a design tool (Fig. 16). Sketches and rough technical drawings are used heavily throughout the process in order to

Fig 18. cont



Final Design – Computer Visualisation – variant 1 *Final Design – 2D Technical Drawing*



4.4.3 Case Study 3. Medis

Client: *Department of Health: Scotland*

Product: *Medis*

Project: *The design of a terminal and associated interface to allow patients to access their personal medical records held on an optical card.*

There follows a summary or overview of the events that occurred during the execution of the project named 'Medis'. The project was carried out by the Centre for Industrial Design on behalf of the Department of Health in Scotland and spanned a timescale between April 7th 1994 and January 24th 1996, however the core work was carried out between 28th July 1994 and 15th June 1995. This project was slightly different to the other case studies in that it comprised the design of both hard and soft entities, a product and interface. The focus of this case study is the design of the product.

4.4.3.1. The Brief

The project was linked to a research programme, which in response to government legislation was assessing the effect of allowing patients to have access to their personal medical records via an optical card. The information on the cards was accessible via a standalone terminal. The client's opinion was that the existing unit, which had been described unflatteringly as a 'brown steel coffin' was having an adverse effect on the findings. The Centre for Industrial Design was commissioned to design a more appropriate unit, which had to contain a number of pre-determined

Fig. 16. Soulagil: Concept Presentation

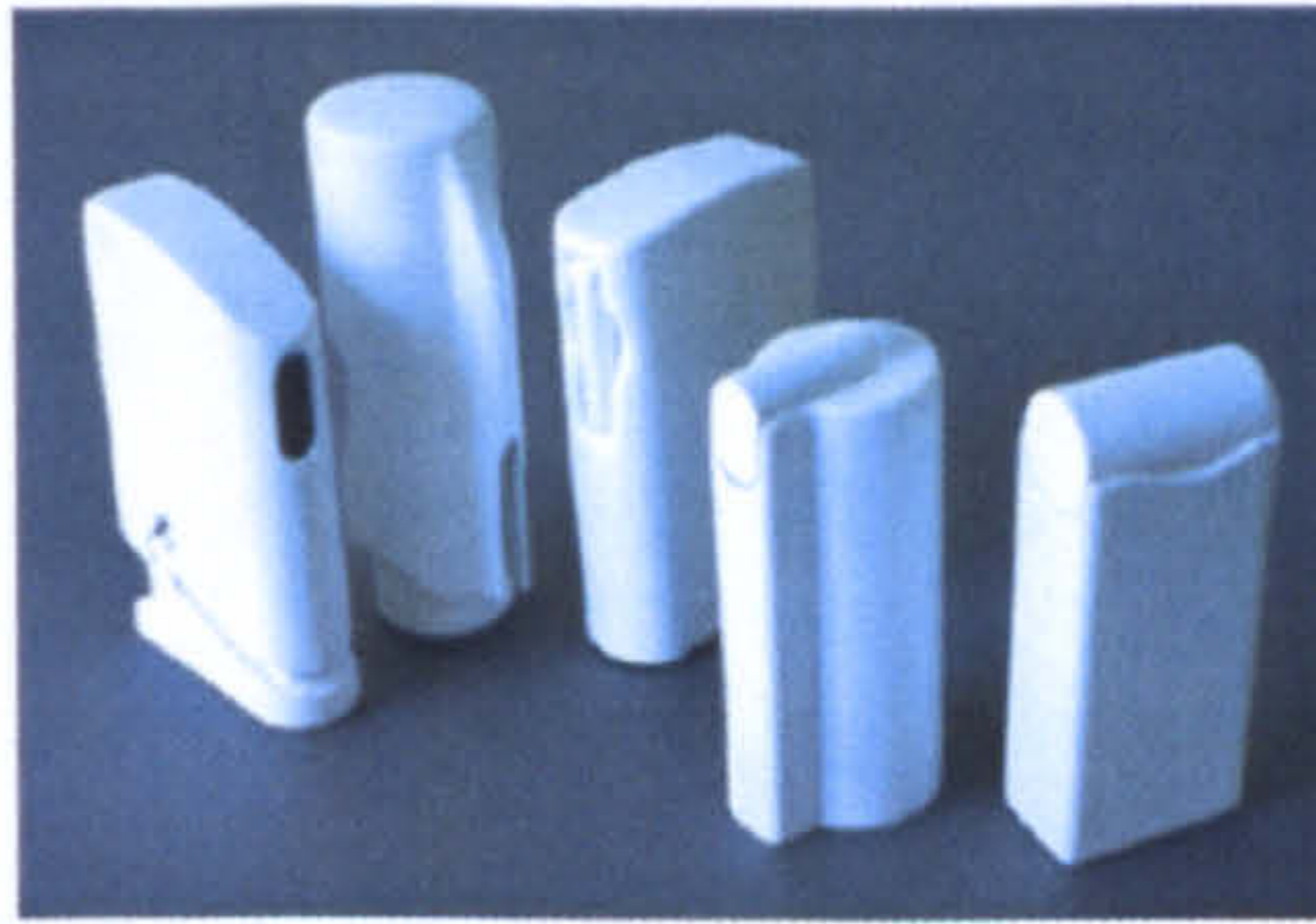
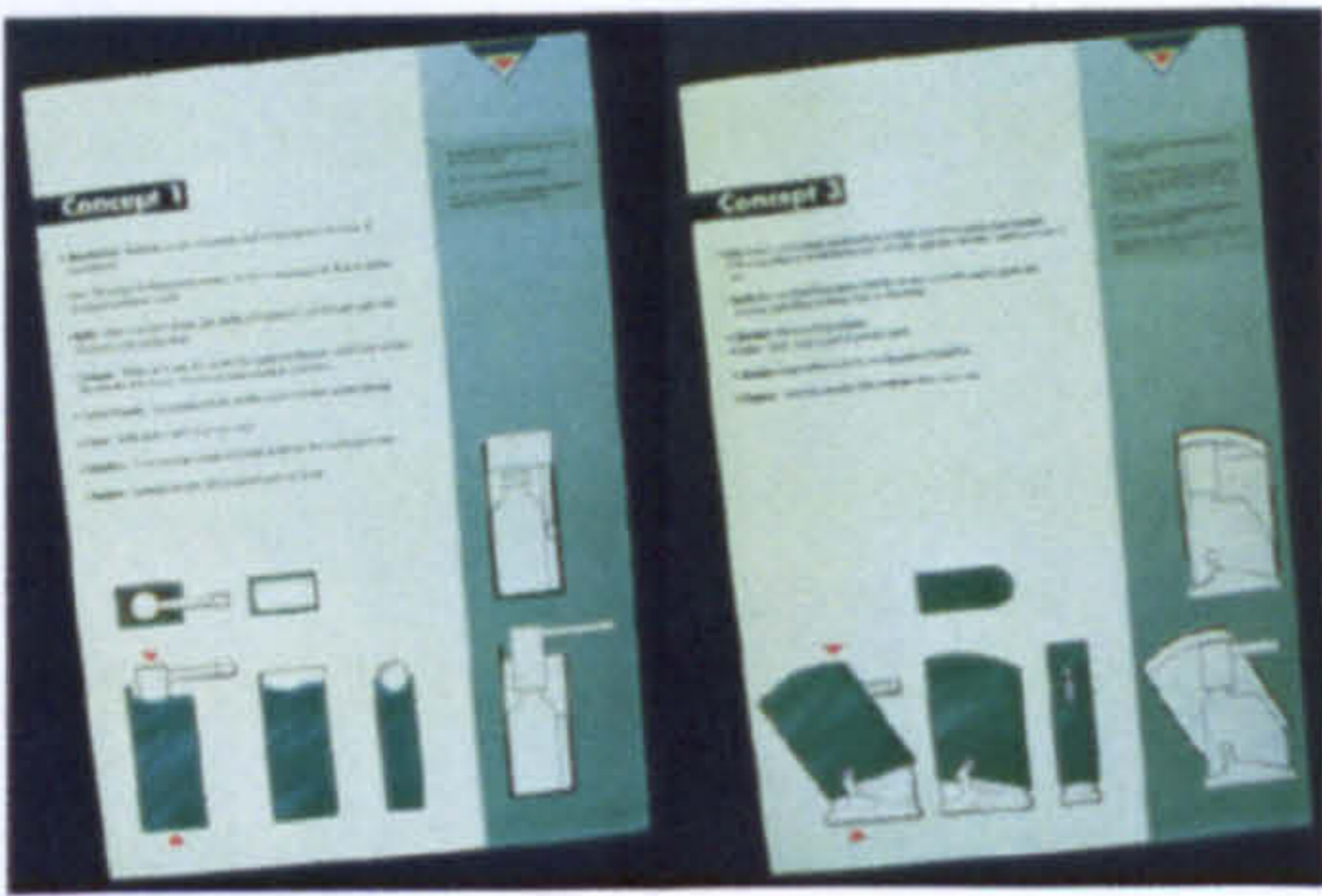

They are presented to the client using a combination of presentation illustrations...

...and appearance models



...and digital models, both with

...and without graphics

Fig. 17. Soulagil: Concept using a modified actuator and a standard bottle

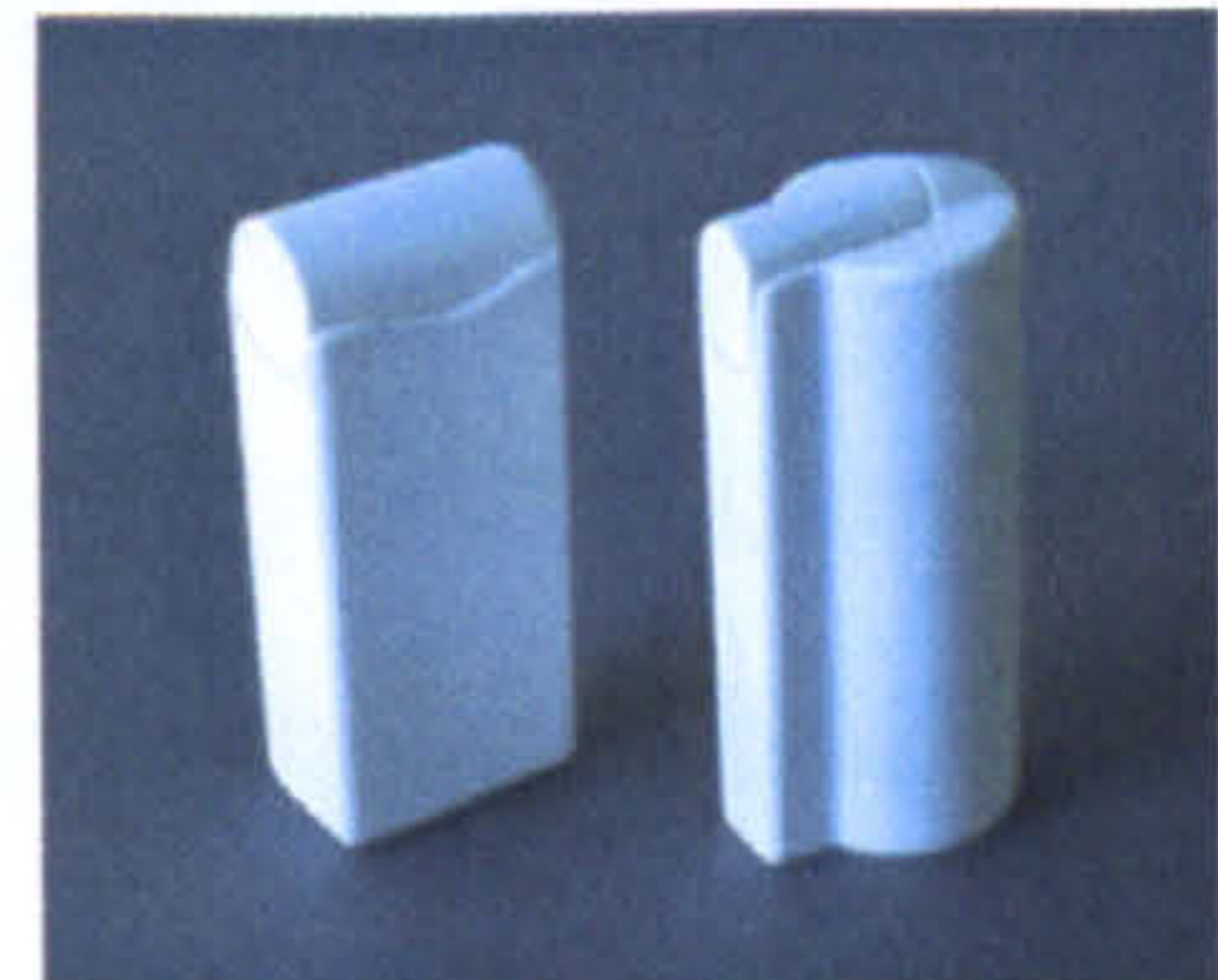
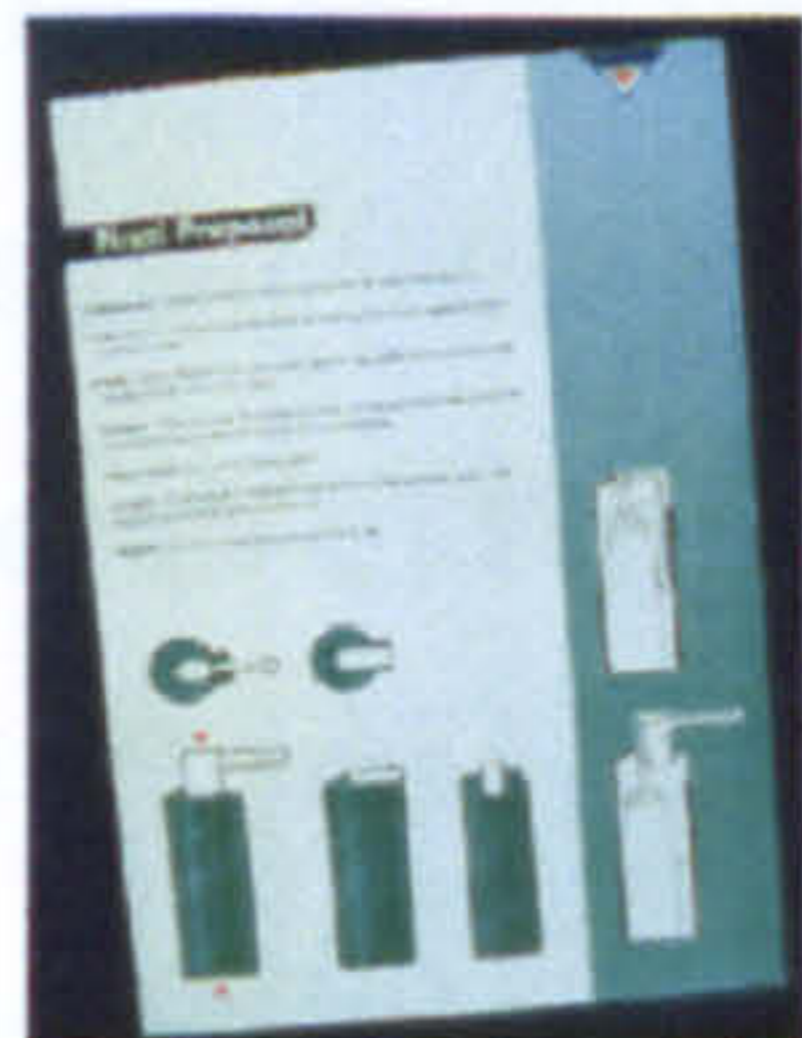
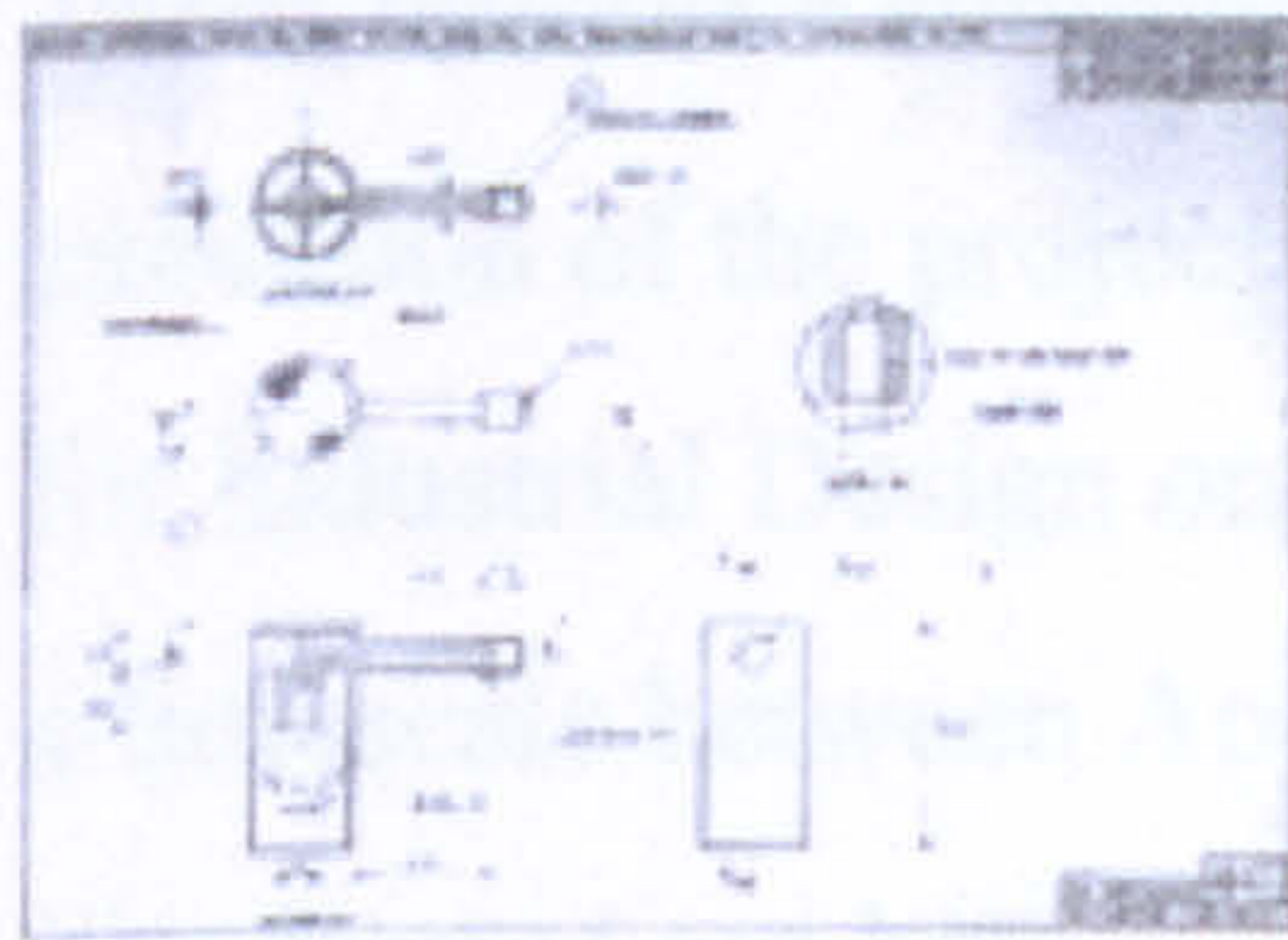

Technical drawing of modified actuator

Presentation Illustration

3D Digital Model

Appearance Model

Fig. 18. Soulagil: Specification Development

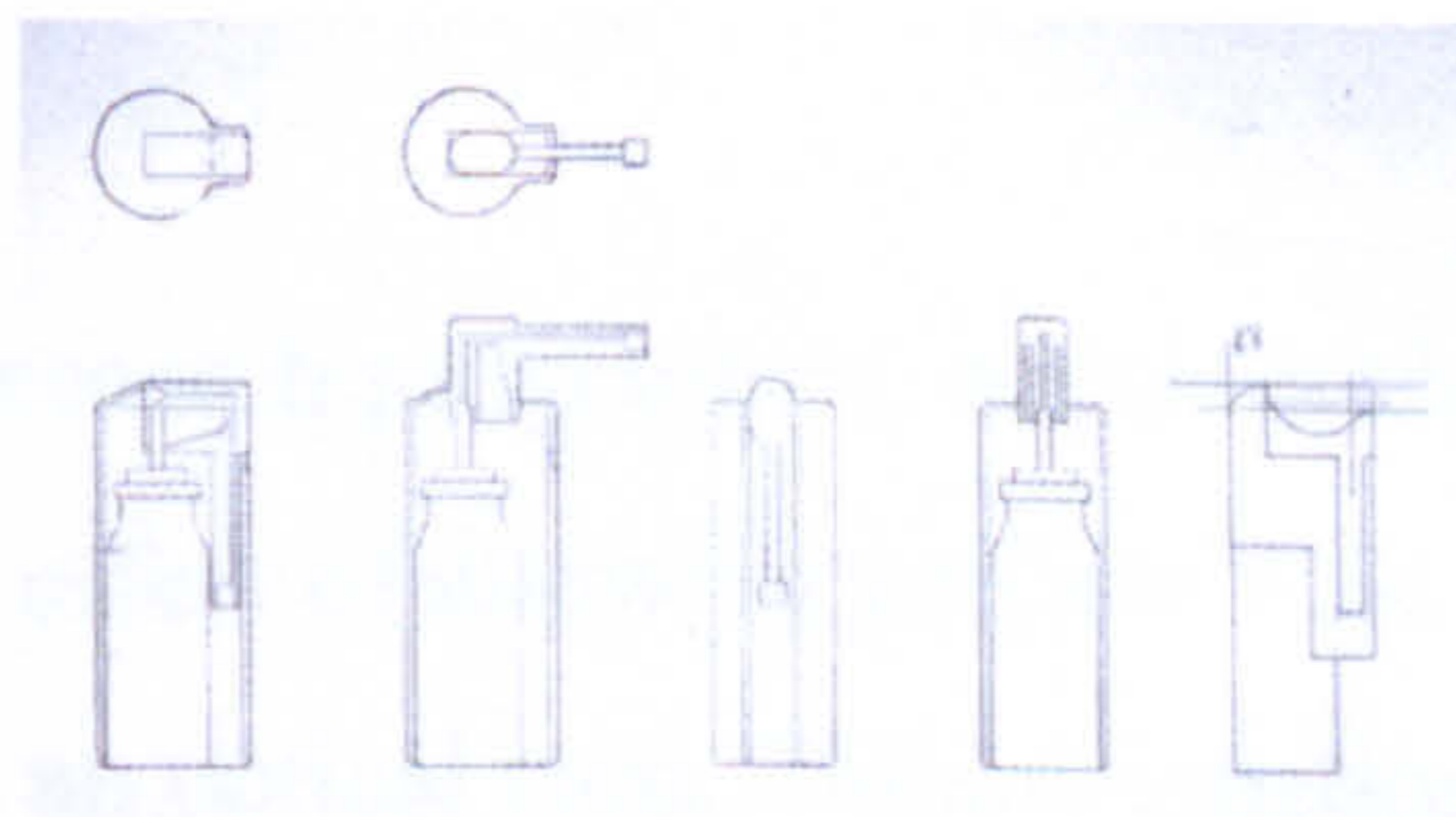
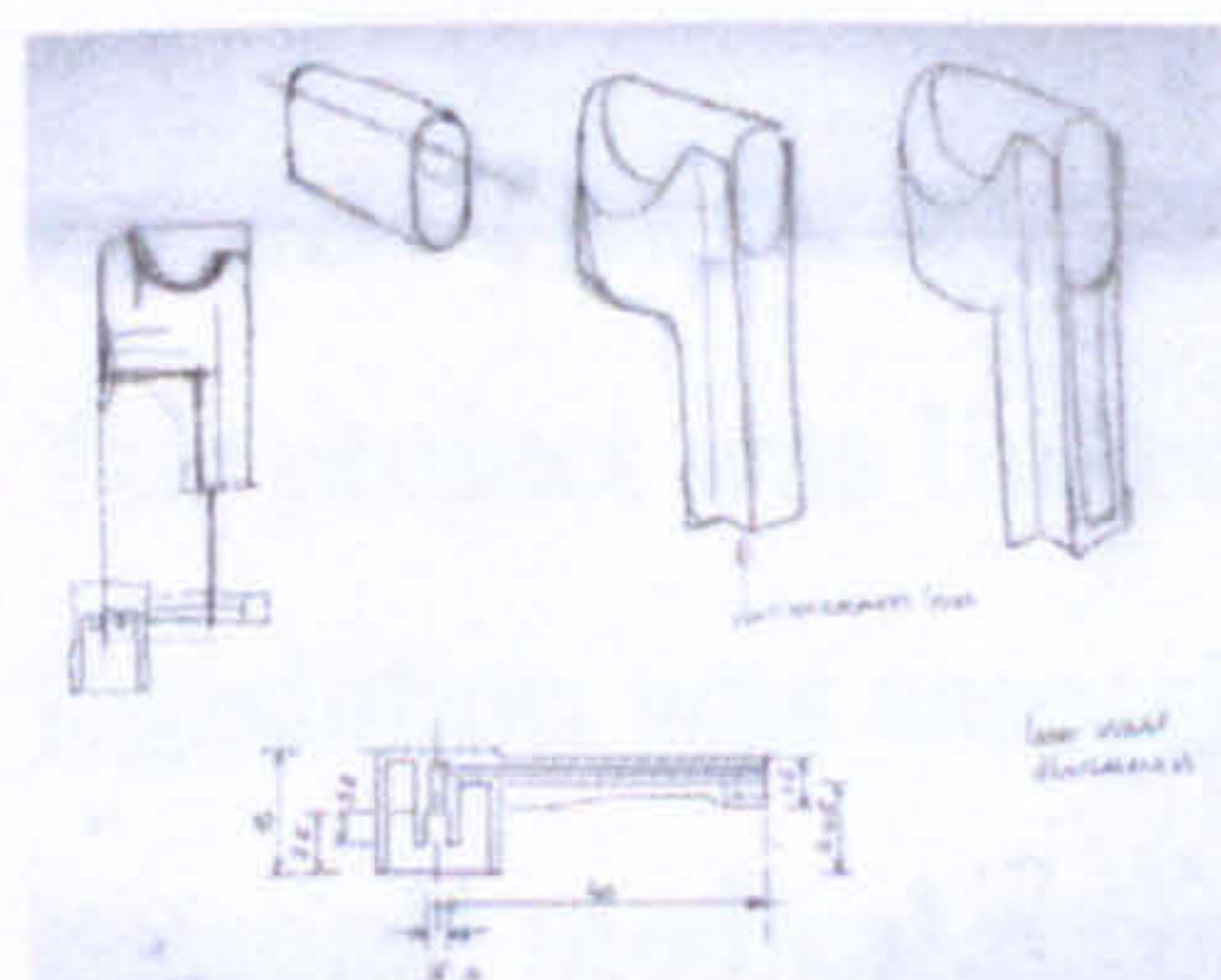

Sketches are used to work out concept details

Technical drawings are used to quickly clarify the concept

continually evaluate the design (Fig. 14, Fig. 15, Fig. 18). Models and computer visualisations (Fig. 16) were an extremely useful part of the process but were created predominantly for the client, rather than as part of the development process. This is probably due to two factors; the only 3D software that was available and employed was an unconstrained modeller, anything created within this medium had to be re-created in a specification driven medium in order that it might be communicated to manufacturers, this would not have been the case had the product been created in a constrained modeller such as Pro/E. Also the product was relatively easy to understand, the mechanisms were simple and easy to visualise, the forms were of low complexity, the use of computer media performed a confirmatory rather than an exploratory function. What this project showed most strongly however, was the power of mixed media, of taking the most appropriate elements from each media and mixing them to form a complete and powerful communication package (Fig. 16). Fig. 14 to Fig. 18 provide a selected visual summary of the project, the full visual summary can be viewed on the CD.

Fig. 14. Soulagil: Initial Concepts

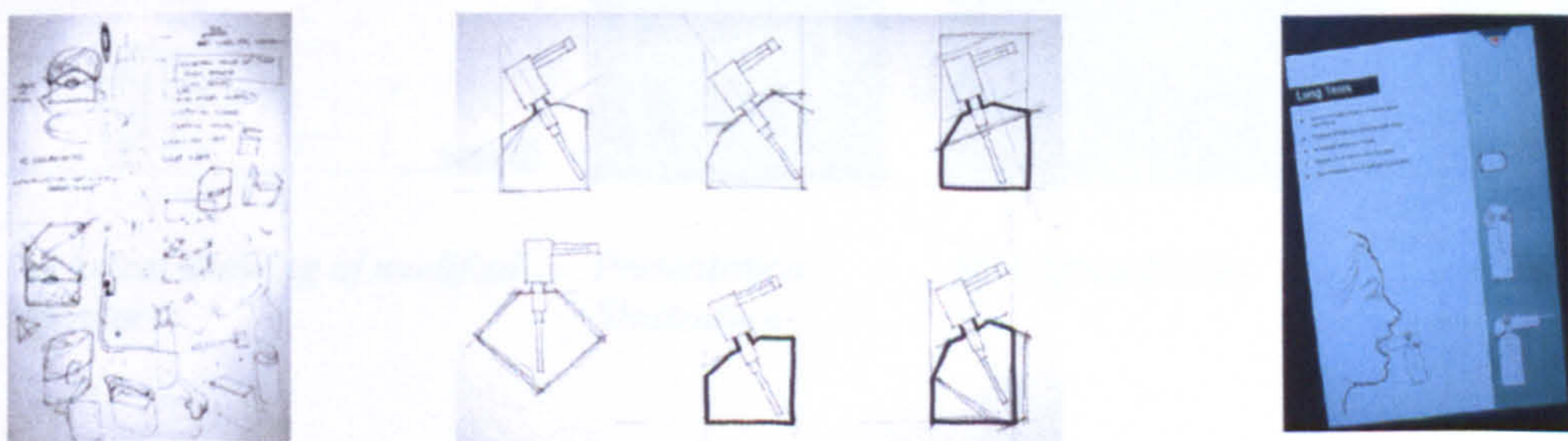

Initial brainstorming sketches

Concept Generation

Hand drawn illustrations present Interim Concepts

Fig. 15. Soulagil: Concept Development

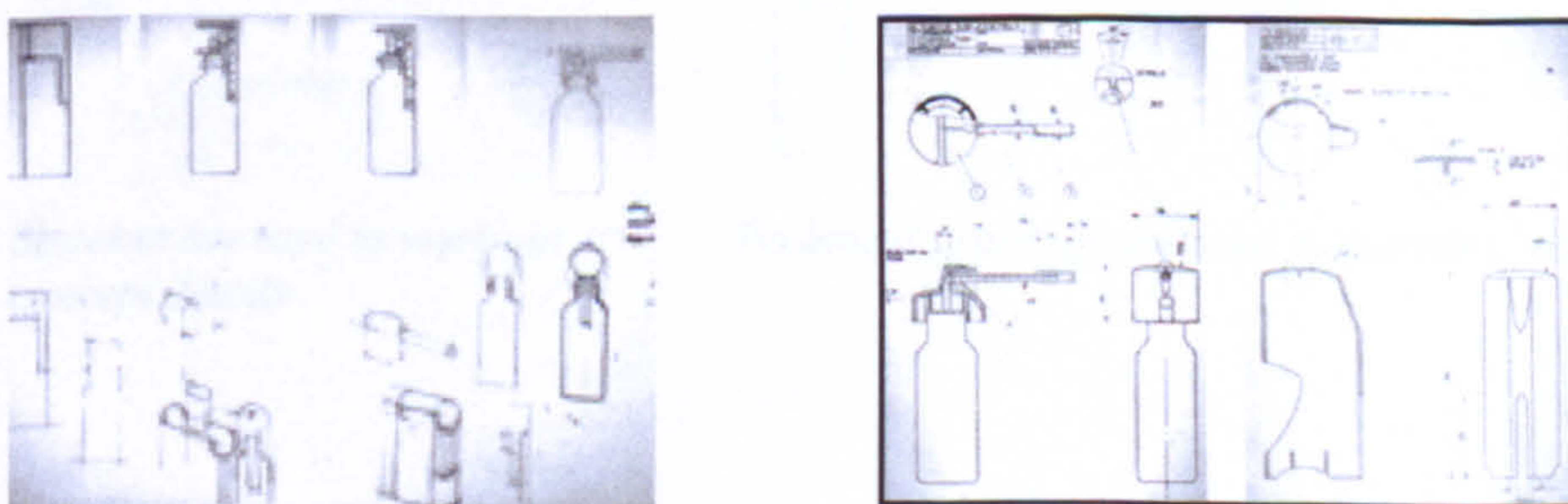

Concepts are developed using a combination of sketches...

...and hand drawn technical drawings

hardware components and had to allow for a range of use and environmental situations. The Centre was further commissioned to redesign the interface which had to be sympathetic to the needs of the end user, be simple to use and easy to understand. Both the interface and the unit had to be friendly whilst retaining user confidence in the accuracy and security of the information presented.

4.4.3.2. The Result

The existing physical product (Fig. 19) consisted of a large brown steel box, which had no sympathetic qualities towards the end user. It was monolithic, had no privacy provision and a screen that was at a height only appropriate for certain users.



Fig. 19. Medis: Existing product (left), final product (right)

The resulting product (Fig. 19) had a large curving screen to give a feeling of privacy to the user and provided an optimum location for branding and instructions. The large flat surface gave the user a place to put bags or printouts. The angled screen enabled a wide range of people to use the unit, from children, to the wheelchair bound, through to a standing adult. The hardware was concealed in a simple ‘cupboard’ so allowing easy access to the various components for maintenance. The use of coloured laminates and soft, calm colours helped the unit fit in with the bright, friendly space of Inverurie Health Centre, the location for the initial prototype.

As a result of the design proposals the research programme received extensions in terms of both time and money. Another MEDIS unit was installed at St Andrews House, the Government offices in Edinburgh.

4.4.3.3. The Process

Reflection on the process illustrates that this project used traditional and digital methods in very distinct stages. The first stages of the project were concerned with coming to terms with the issues and because of the scale of the project, familiarisation with the volume constraints. This resulted in a predominantly hands-on approach, using lots of sketching and soft modelling (Fig. 21 & Fig. 22). However once these basic issues were resolved 3D modelling became a very useful tool (Fig. 23 & Fig. 24).

Although the product looked simple the geometry surrounding the angled & suspended monitor, combined with the curving back were especially complex. Without doubt, the ability to produce the 2D cutting patterns from the 3D models resulted in a considerable time saving. In addition to this we were able to check component clearances very easily and put the product quickly into context to establish exactly how much space it would need and how this would affect its environment.

The use of 3D within this project was essentially more for practical than cosmetic purposes, and essential in resolving efficiently the technical requirements of production. The real human impact of the project came through the use of full size finished models, through which we were able to make decisions about interaction and ergonomics (Fig. 24).

Fig. 20. Medis: Research



Researching the environment: Kintore



Researching the environment: Inverurie Health Centre

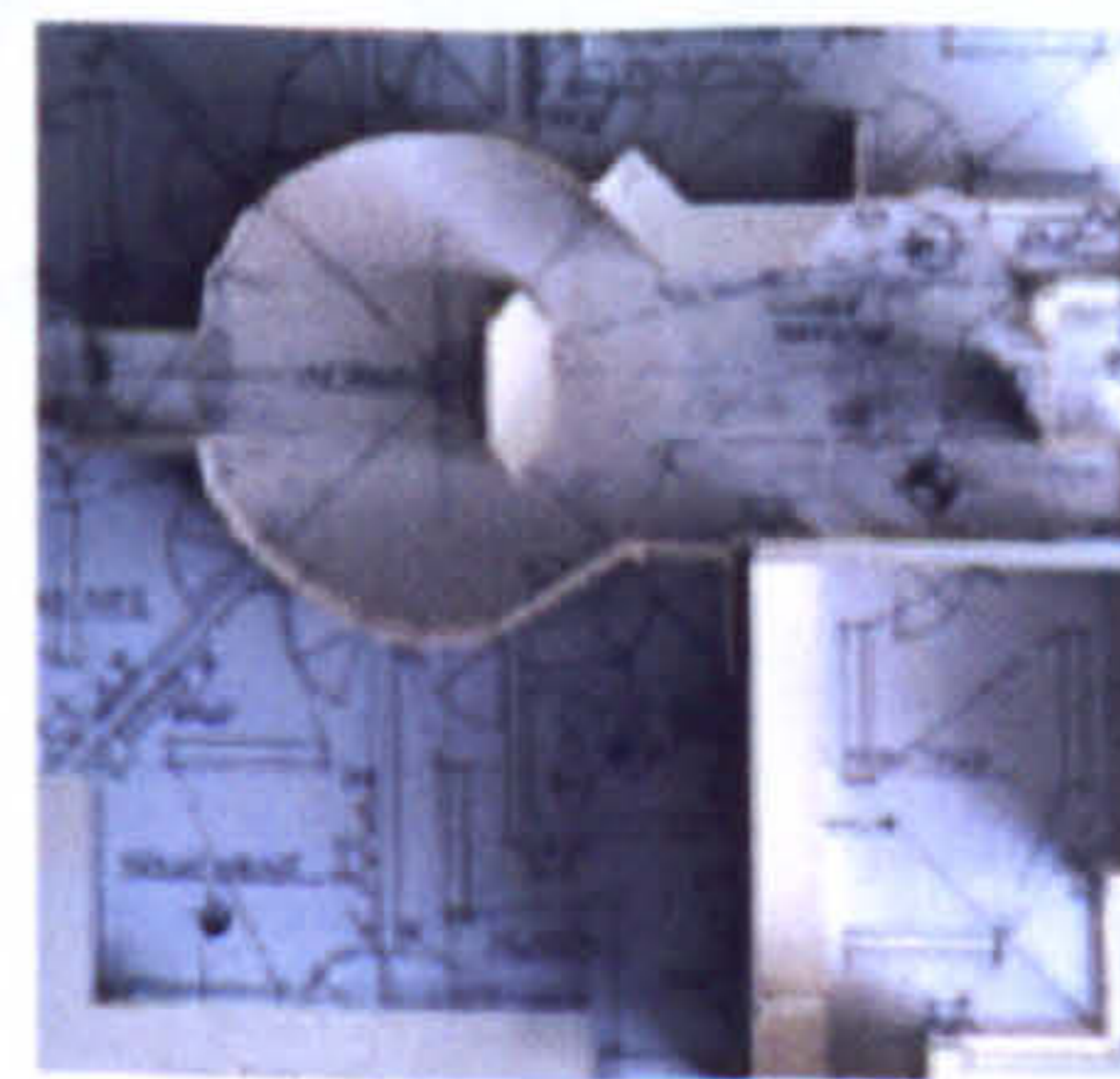

Scale Model: Kintore



Scale Model: Inverurie

Fig. 21. Medis: Initial Concepts

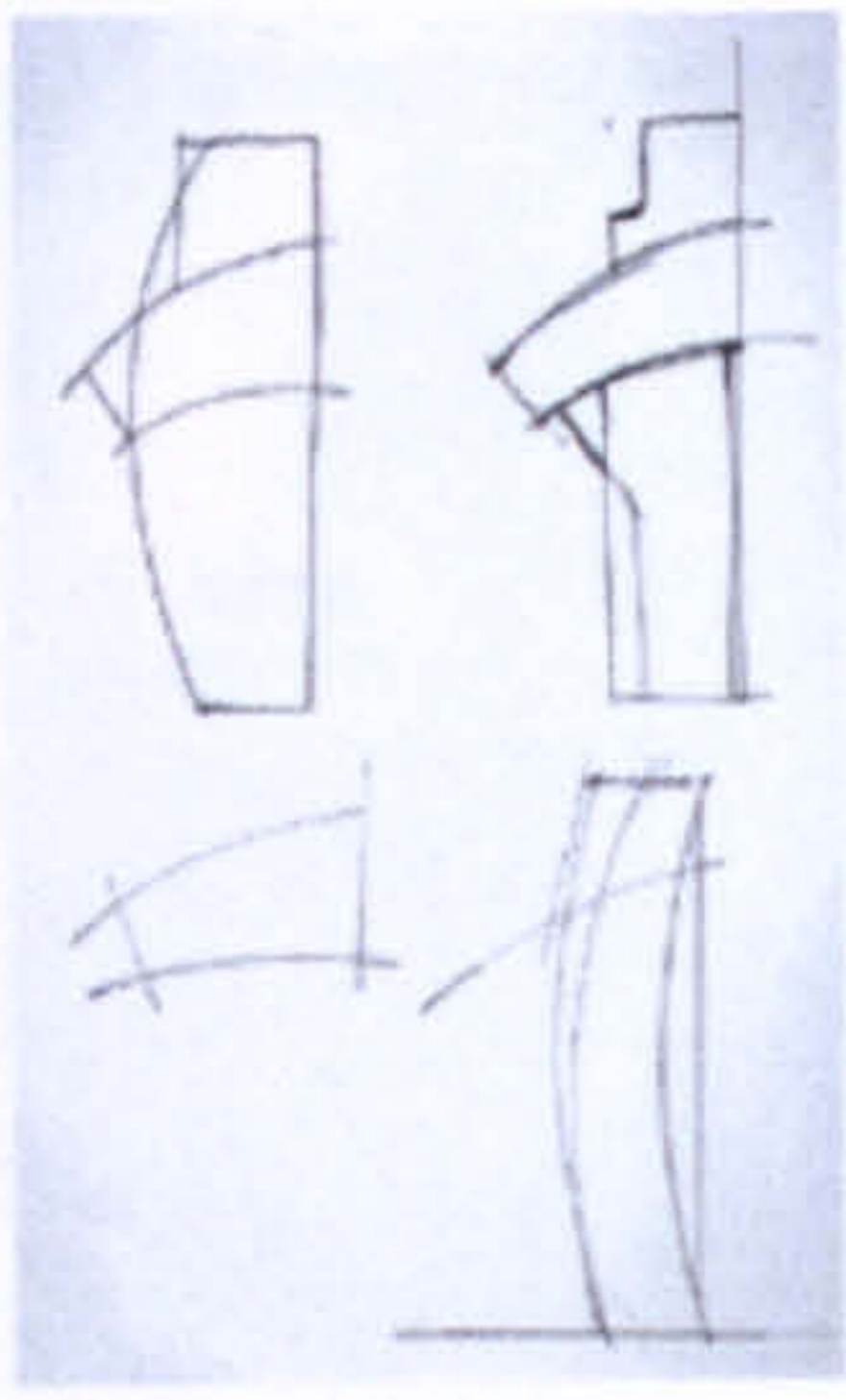

Initial brainstorming sketches



Full size schematic configuration rigs

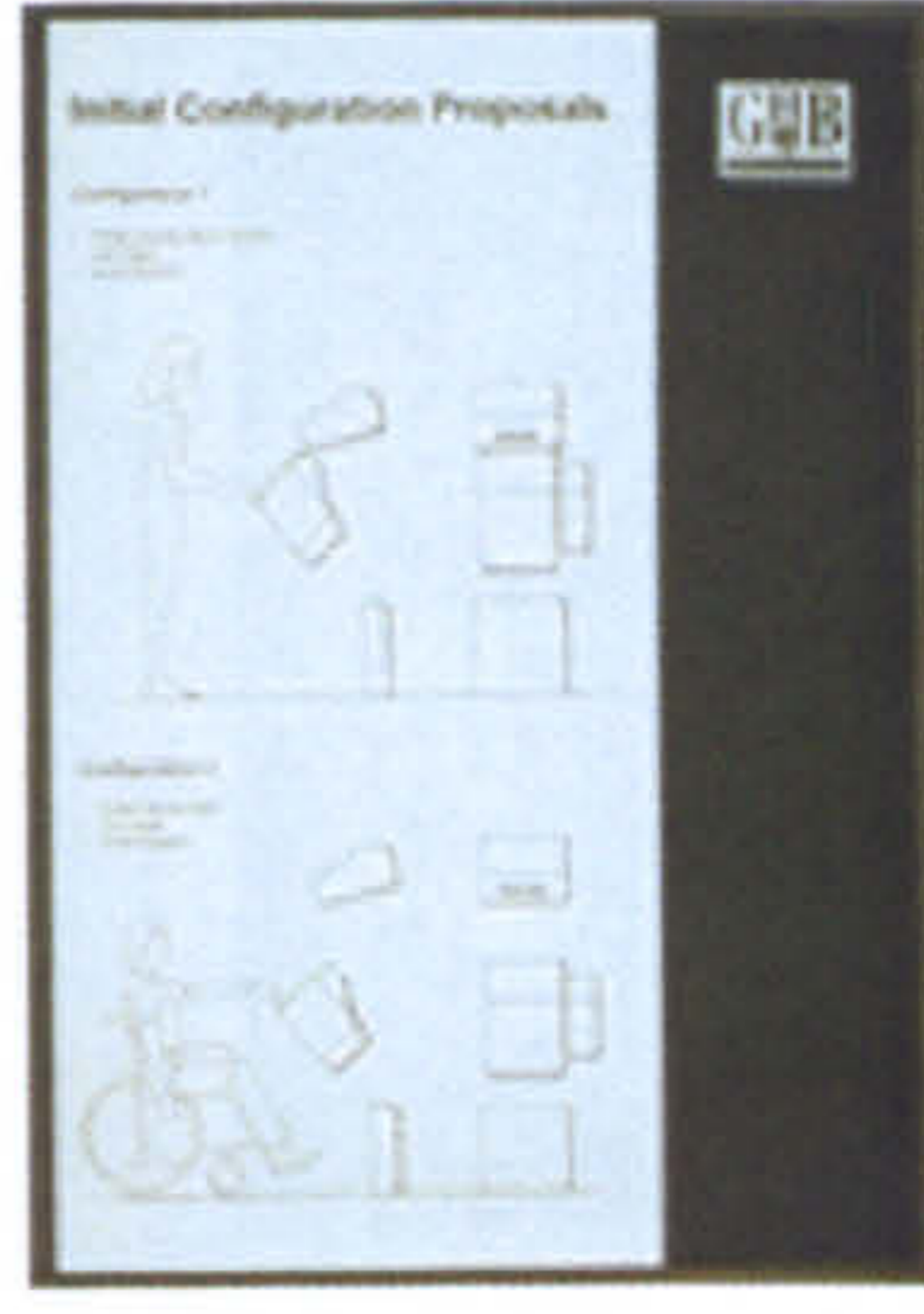

Schematic configuration diagram for Initial Concept Presentation

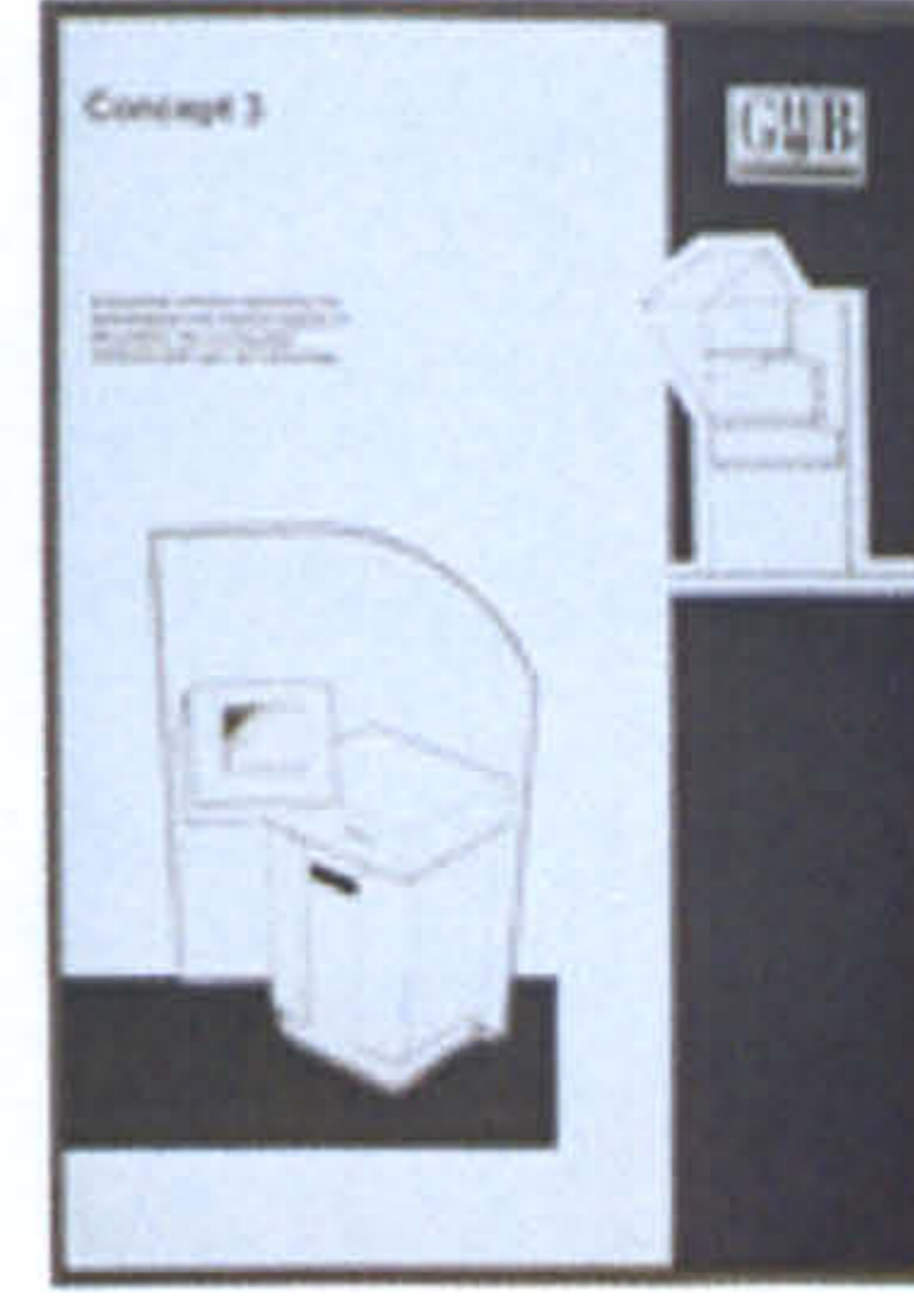

Concept illustration for Initial Concept Presentation

Fig. 22. Medis: Concept Development – Asymmetrical Concept

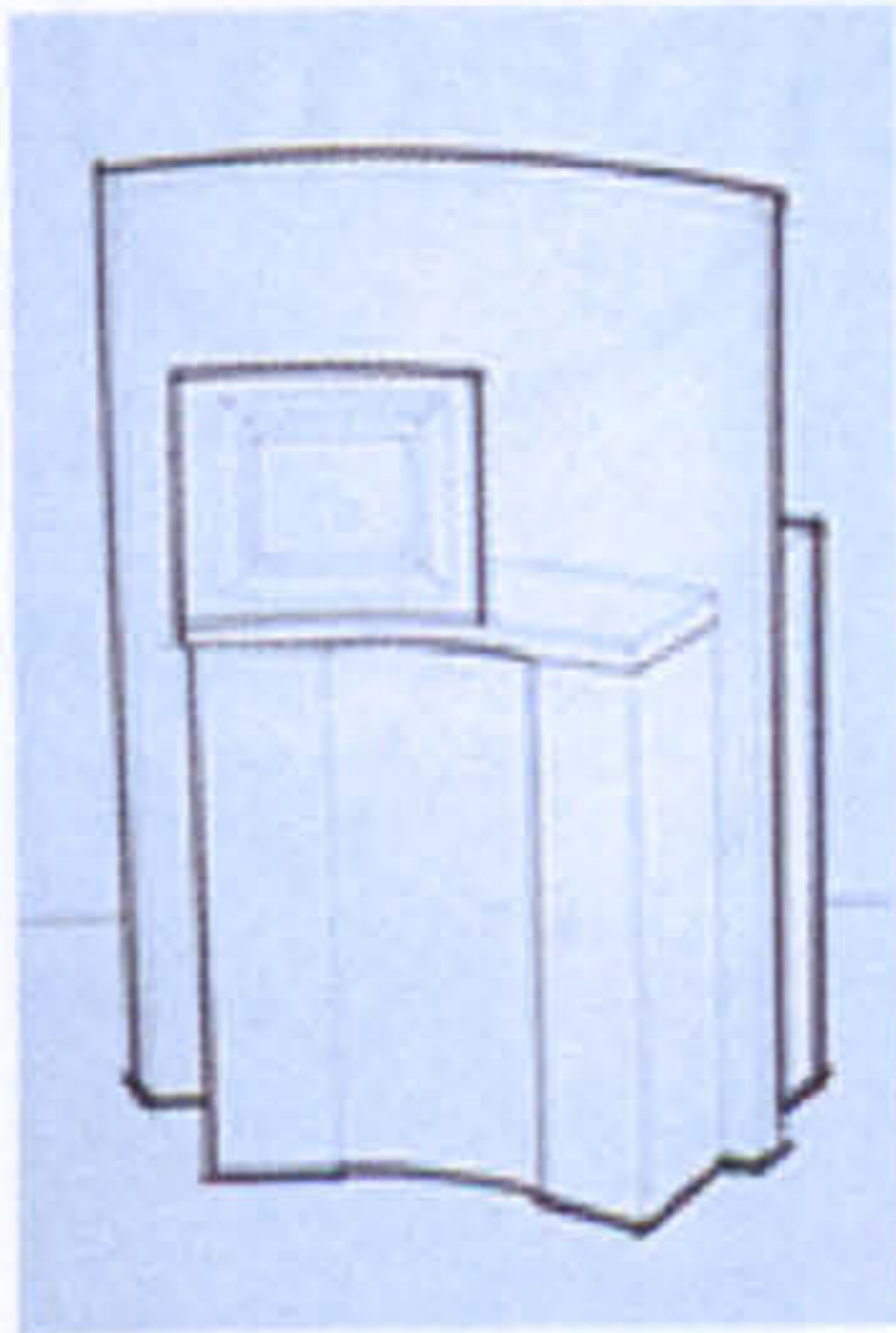

Sketches & drawings



Scale sketch models



Full size sketch models

Fig. 23. Medis: Concept Presentation



Full scale soft model

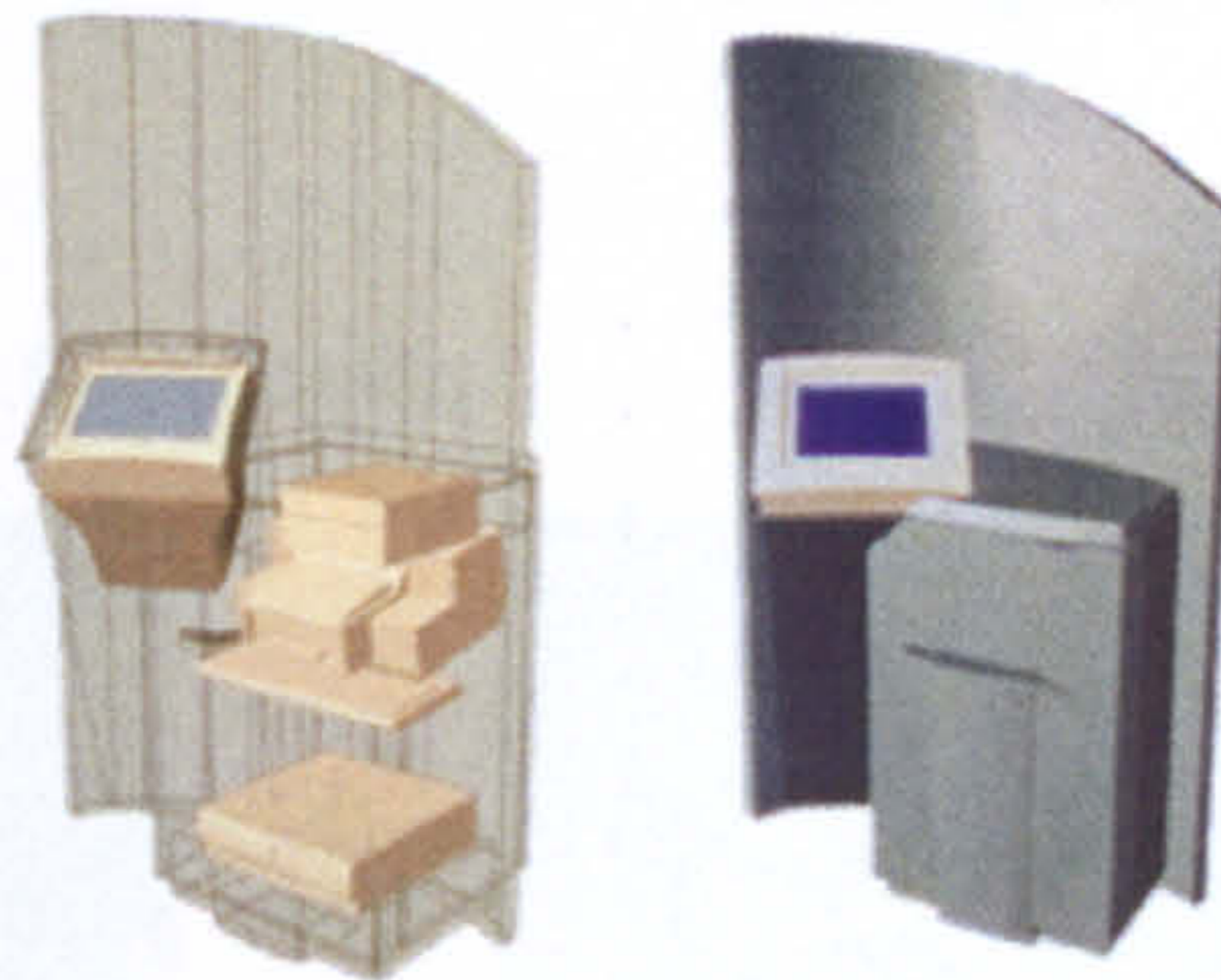

The 3D digital model is built around the internal components

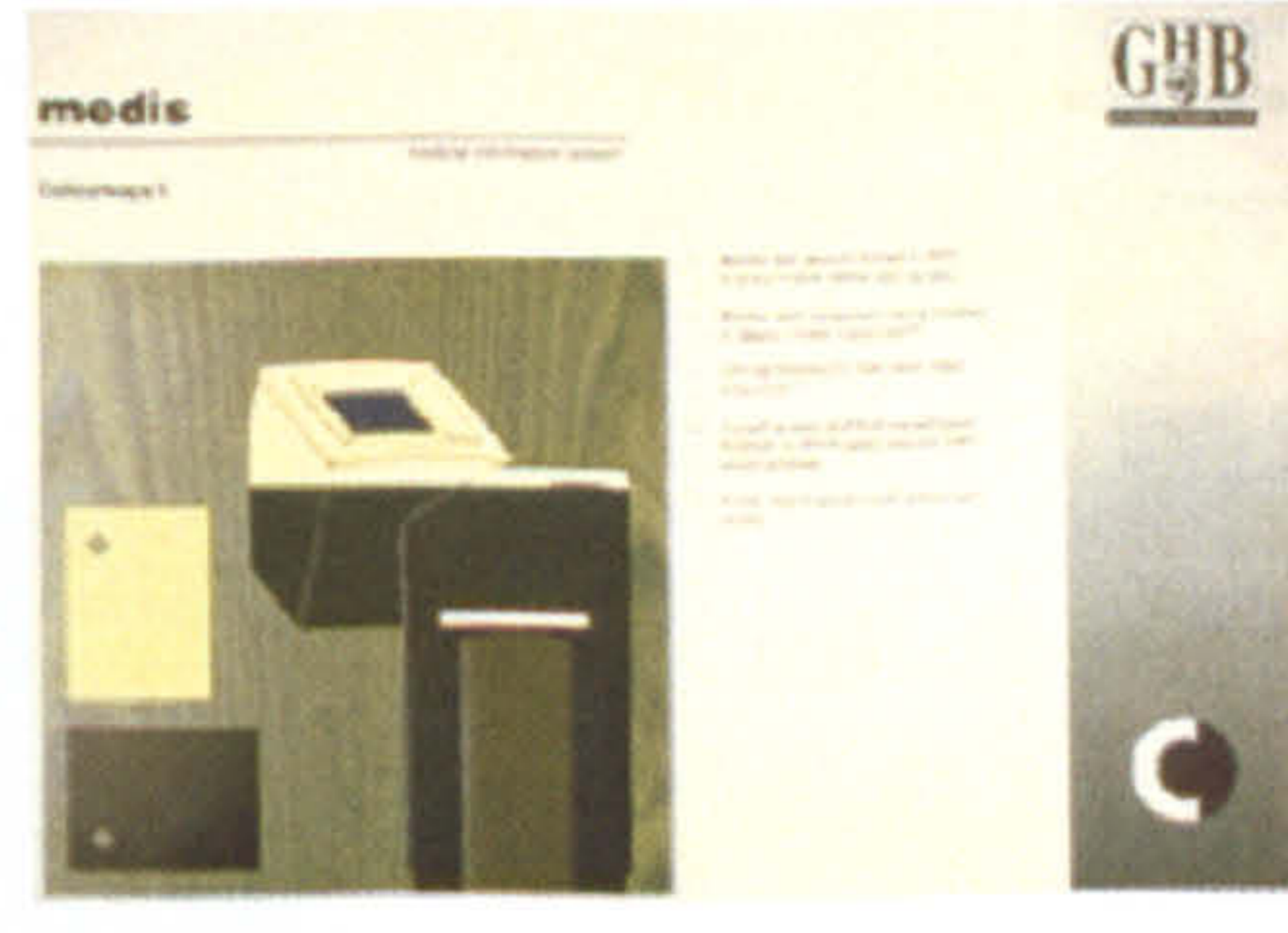

Presentation board showing finish options

Fig. 24. Medis: Final Design Proposal

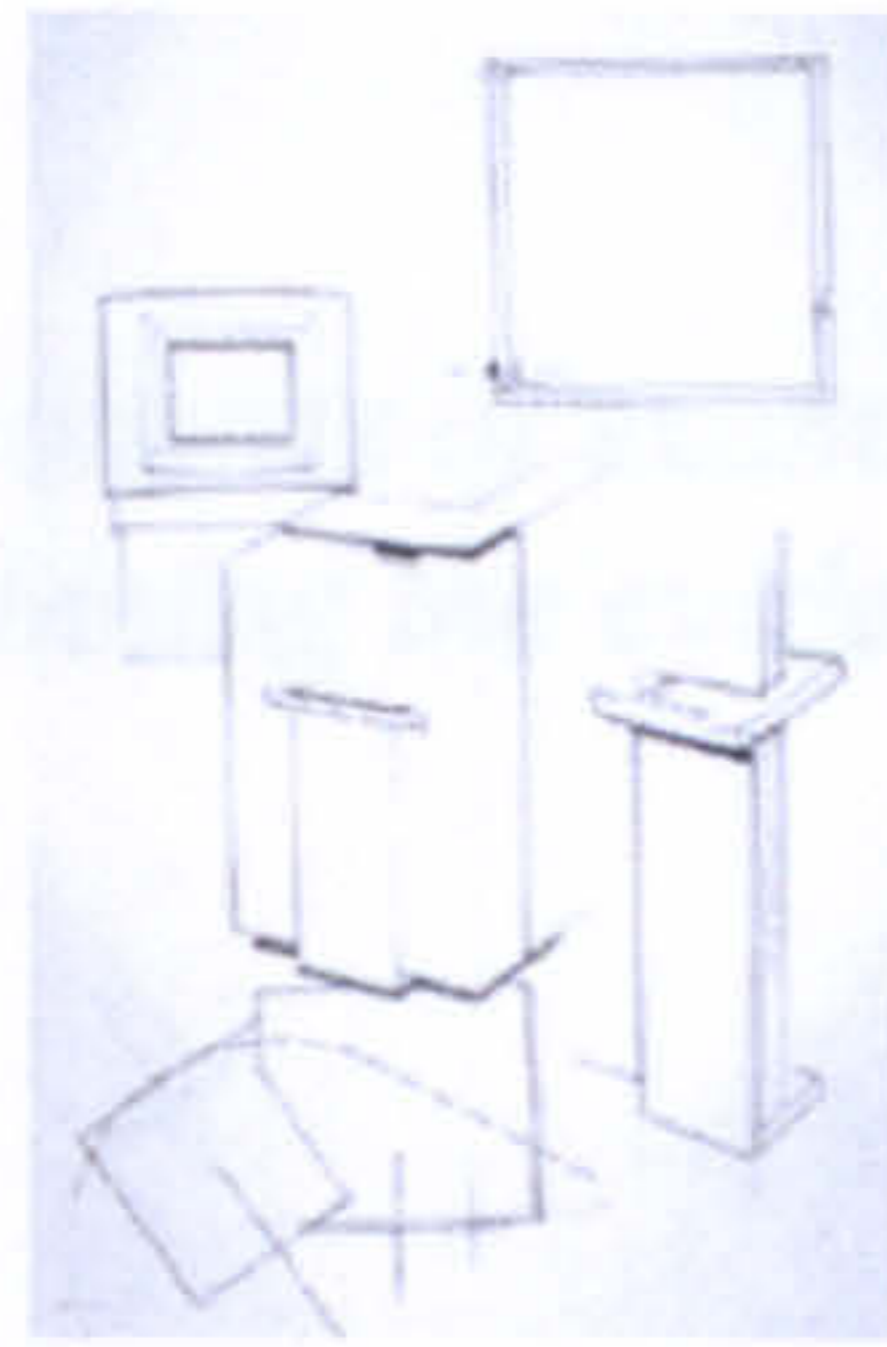

Full size appearance model

Final design detailing

Constrained 3D Digital Model

Fig. 25. Medis: Corporate Identity Proposals



Initial concept

Final logo



Initial Prototype

Installing the final prototype

Fig. 26. Medis: Final Product & Specification

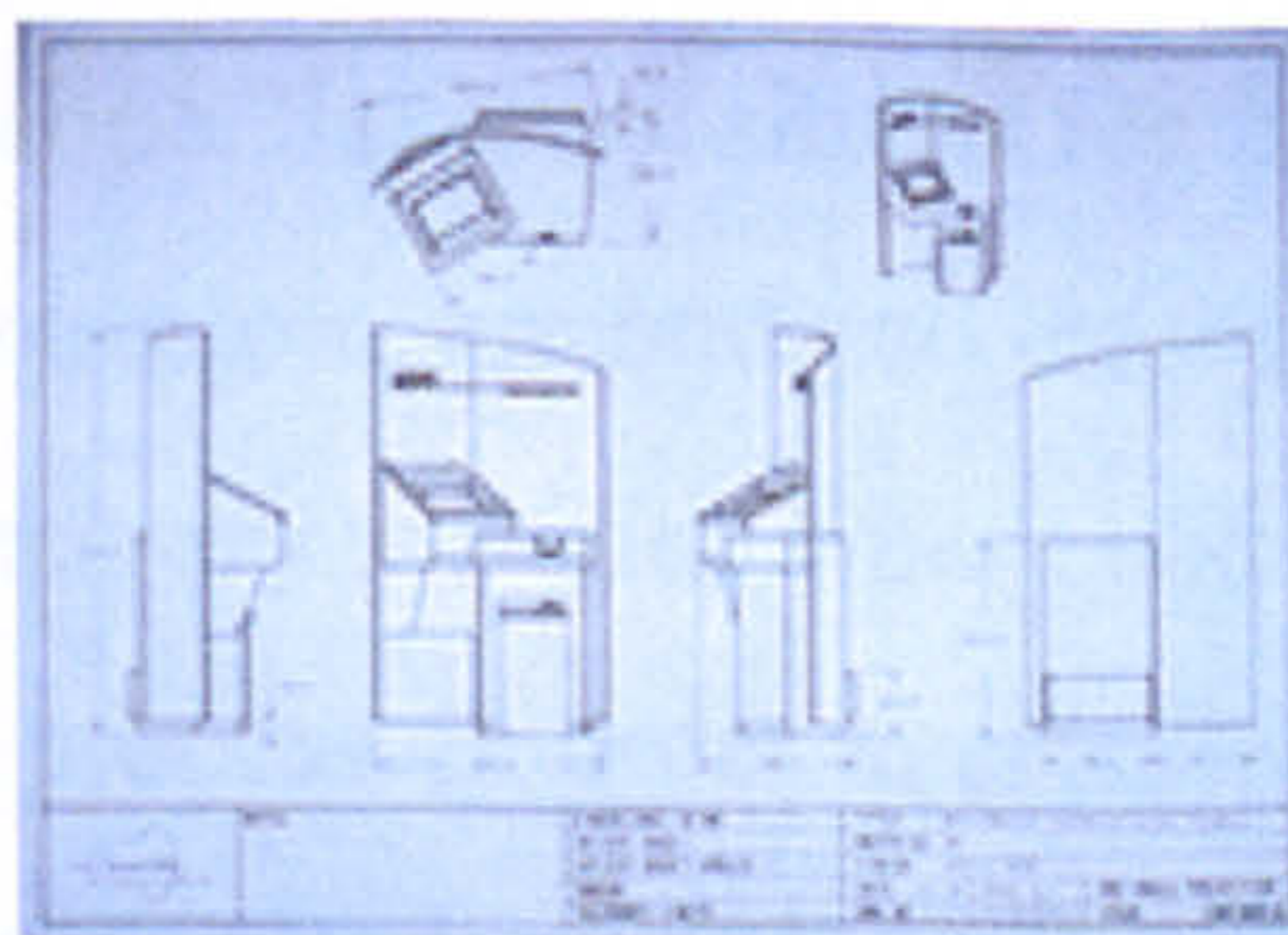

Final prototype comparison

Final specification documentation

4.5 Case Study Analysis

*“Data analysis consists of examining, categorising, tabulating or otherwise recombining the evidence to address the initial propositions of the study”*¹⁵

4.5.1 Introduction

The case study material is collated and tabulated in a systematic way following the case study protocol defined in section 4.3. The purpose of the case study analysis is to ‘boil down’ that material through a process of *reflection on reflection on practice*. Although the data are organised and categorised, they require analysis in order to establish how they might inform the factors affecting the use and integration of various forms of media, and more specifically 3D digital modelling media, with the industrial design process. The objective of the analysis is to find some parity between the findings of the case studies, providing some of the material to start to enable the generalisation of these findings to industrial design practice as a whole. This chapter discusses the process of analysing the case study data, and discusses the results of the analysis.

The propositions derived following the initial case studies (2.6.5) suggested that there were a number of factors requiring consideration when attempting to integrate 3D modelling media with the industrial design process. However, as the formative case studies were very limited in scope, the propositions required testing in a range of more in-depth cases. In order to explore, expand and establish the wider relevance of these factors, it was deemed necessary to define where and why the various forms of media might be used within the process. In order to establish the position of digital media within the process, it is necessary to look at both traditional and digital media types. The characteristics of those media can then be identified along with any correlation between the characteristics, and where and why the media were being used. As Yin¹⁶ points out, case studies are used to reveal what people are actually doing instead of what they think they are doing. Rigorous analysis of the case study

data provides a valuable insight into the integration of 3D digital modelling media, enabling a clearer picture of the factors affecting their use and therefore where, when and under what circumstances it might be appropriate to use such media within the industrial design process.

Following the completion of the case studies, but prior to their collation and analysis, an ad hoc. hypothetical construct of the perceived results of the case study data was generated. Known within the confines of this study as the 'hypothetical map', it defines the probable integration of digital and traditional media within the industrial design process. This construct was a result of initial and informal reflection on the case studies, in addition to reflection on all commercial projects being carried out within CfID at the time. The hypothetical map acted as a starting point, a method of focusing thinking, providing a framework for the full analysis of the dedicated research case studies. The hypothetical map is fully explained and illustrated in section 4.5.5.

A number of elements comprise the discussion of the case study analysis process. Firstly an appropriate methodology is identified and defined, utilising theories from Yin¹⁷ and Langrish¹⁸. The specific analysis techniques are adapted from Yin's method of 'Cross Case Analysis'¹⁹. A description of the analysis process follows, exploring the process of extracting the case study data and then constructing it into a meaningful form. Finally, the results of the analysis are synthesised in order to define a map describing the integration of 3D digital modelling media within the industrial design process. This, when compared with the hypothetical map, enables the researcher to establish any differences between what was thought to have occurred compared to what actually occurred, based on the evidence provided by the case studies. This enabled the researcher to establish what was actually happening as compared to what was thought to be happening – thus complying with the requirements of a case study approach. Also, the hypothetical map can be seen to represent a kind of informal hypothesis of how 3D digital media integrates with the

industrial design process. The data represented by the final map will serve to ratify or disprove the perception with the reality.

The specific objective of the analysis process is to define a map, based on commercial design practice, which describes the likely integration of 3D digital modelling media into the industrial design process. This will then serve as a backdrop against which the characteristics of these media, and therefore the factors affecting their use, can be investigated and discussed in more detail. The ultimate objective of the research programme is to provide the industrial designer with an insight into the appropriate use of 3D digital modelling media truly reflecting practice. The outcome will take the form of a 'Heuristic Map for Digitally Integrated Design' that enables the industrial designer to explore what forms of media are most appropriate at certain stages of the process, why they might be used and what characteristics they have to make them appropriate or inappropriate for use at certain points in time and any factors affecting that use. The objective of which is to help the designer, when faced with a range of tools, make an informed decision about how best to use them.

4.5.2 Methodology

Carrying out and reporting on case studies is one part of the process of studying what we are doing instead of what we think we are doing. Further, reflection on practice tells us a lot about each individual case, but thorough case study analysis is required to produce both reliable and tangible results.

4.5.2.1. Case Study Design

As these case studies rely on data collected by active participators, the interpretation of what actually happened during the case is open to subjective interpretation. It is therefore imperative that the analysis process is as rigorous as possible in order that any results can be seen to be as objective and reliable as possible. Although much of the analysis methodology adopted has been from the field of social sciences²⁰ it is believed that many of the techniques are appropriate and can be effectively employed in the analysis of design based case studies. Langrish²¹ has provided a key paper on

design case study analysis, but even in established fields case study analysis strategies are not well developed and the adoption of strategies from other disciplines is not unknown. With the field of design research still relatively new, it is a common phenomenon to look to other research disciplines for guidance.

This study follows a multiple case approach, which is commonly used in the field of educational research. Much of the methodology adopted in this study as well as in action research in general, is adapted from educational research methodology. It can be seen therefore that the adoption of a multiple case strategy is a natural progression. The case studies carried out during this research adopt the theory of 'replication logic'. This can be seen to be similar to the type of study used in medical research, where a similar result is predicted in each case and when similar results are obtained, *replication* is said to have taken place²².

Theoretical & Literal Replication

The logic underlying use of multiple case studies is such that each case should be selected so that it either;

- predicts similar results (literal replication), or,
- produces contrasting results but for predictable reasons (theoretical replication)²³.

Yin²⁴ states that two to three literal replications are adequate if the case theories are different and the subject is not of a critical nature. For example: a medical application such as clarifying that a drug was safe would require the researcher to be completely certain of the results. However in the case of design, each context is unique and the issues are rarely critical to the same degree. With respect to the use of 3D technologies within industrial design it was predicted that each case would produce broadly similar results, this prediction was made on the basis of the researcher's experience in carrying out many design projects, not covered by this

research study, which utilised these technologies. The objective therefore was to obtain an element of literal replication.

4.5.2.2. Analysis methods

Analysis methods need to be sufficiently reliable that under similar circumstances another investigator might make the same findings and conclusions. The goal of this reliability is to minimise the errors and biases common within inherently subjective methodologies such as action research. The research followed a process whereby each case consisted of a ‘whole’ study in which evidence is presented to support the conclusions for each case. The conclusions for each case then require replication by other cases. The following diagram shows some parity between the research method followed by this study and a case study method with cross case analysis. The words in italics illustrate the amalgamation of this method with the action research process. The original diagram is that presented by Yin as a representation of a case study method. The original diagram is shown in black serif type, the words in red san serif italics signify the research method adopted by this study.

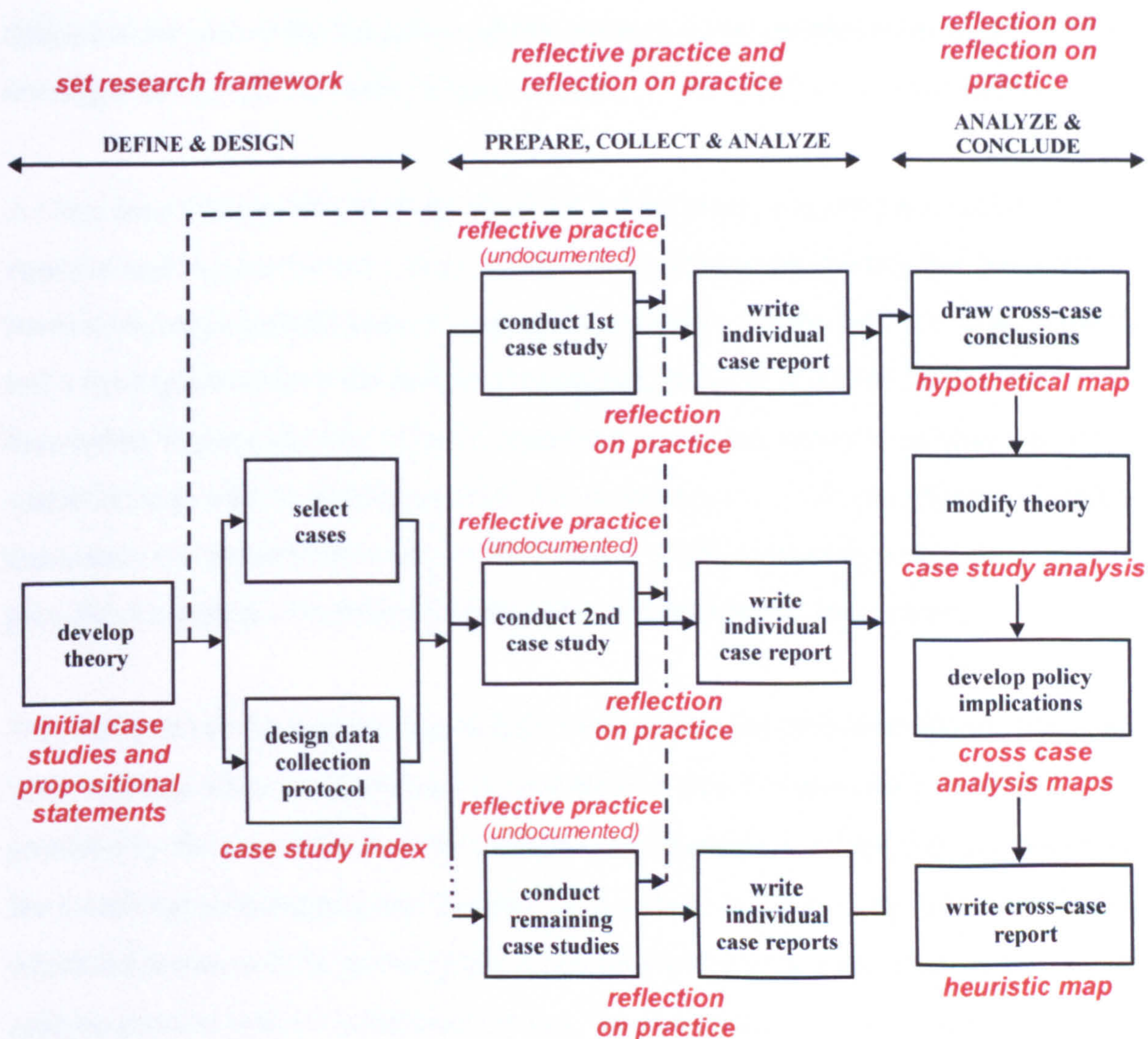

Fig. 27. Case study method (in black) shown amalgamated with the research method adopted by this study (in red)²⁵

Part of the preparation for case study analysis is to define an analysis strategy. There are two commonly used strategies for case study analysis²⁶:

1. *Theoretical propositions*: this strategy is concerned with investigation into the original theoretical standpoint that was taken, that led to the requirement for a case study to be carried out. The execution of the case study would serve to study and explore the theoretical proposition utilising the data provided by that study. Within this thesis, the theoretical proposition would be represented by the propositions

defined at the end of the formative research phase. These propositions might then be investigated through the study of specific data, illuminated by the case studies.

2. Case descriptions: this strategy develops a descriptive framework in order to organise and explain the case study. In the case of this investigation, the descriptive framework might include aspects such as the selection criteria for case study projects and a description of how the project corresponds with the research design. The descriptive framework then helps to organise the analysis process, and can include quantitative as well as qualitative data, that is objective as well as subjective. Within this thesis, the framework might be represented by the case study index, as it provides a common representative template for each project description.

This research can be seen to rely on both of the strategies described above. The case study analysis relies on theoretical propositions in that it uses as its basis data provided by the propositions (2.6.5) and the hypothetical map. But this data requires the researcher to develop a case description to define the map as the backdrop against which the theory will be investigated. It can be seen therefore that each strand of the analysis process follows a different strategy, but essentially comes together as an adapted form of ‘Cross Case Analysis’²⁷.

4.5.3 Cross Case Analysis Techniques & Methods

There are four key analysis techniques that may be employed in pursuit of effective and reliable cross case analysis:

- *Pattern Matching* logic²⁸ compares an empirically based pattern with a predicted one. Coinciding patterns help strengthen the internal validity of the analysis and are related to the variables of study.
- *Explanation Building* is a type of pattern matching where an explanation is built about the case in order to analyse the case study data. A phenomenon is explained by identifying a set of casual links; unlike the previous form of pattern

matching the explanation is developed in an iterative manner similar to refining a set of ideas.

- *Time Series Analysis* is similar to that used in experiments, changes in events within a single variable are traced over time. Often used in conjunction with other techniques as most case studies involve some chronological elements.
- *Program Logic Models* are a combination of pattern matching and time-series analysis useful for explanatory & exploratory case studies. A proposed logic model will be ratified (or not) by empirical data resulting from the case study analysis. Central to this technique is the existence of repeated cause & effect sequences, if these are proven by the data, then a generalised finding can be made.

4.5.3.1. Variables within Pattern Matching

In many ways the techniques described above all represent a form of pattern matching. Pattern matching within case study analysis is likely to hinge around a number of variables, these variables may be dependent or independent. Defined as the 'outcomes' of the case study²⁹, it is against these 'variables' that the analysis is made.

Dependent variables do not change across the different case studies. A case study based on dependent variables will predict the outcomes, which might be different for each study, but based on the same set of variables. The use of dependent variables can produce both literal and theoretical replication. Literal replication is found when similar case contexts produce similar results, theoretical replication is found where there are different case contexts producing different results but for predictable reasons.

The use of *Independent variables* is based on analysis via the development of rival theoretical propositions. This involves a mutually exclusive pattern of variables, where the variables thrown up by one explanation cannot be utilised by another explanation. Each variable may support different types of characteristics and relate to

different events, and may be assessed independently by different measures and instruments.

4.5.4 Selection of analysis methods

As was discussed in 4.2, the research method employed case studies with a combination of exploratory and explanatory characteristics with the nature of the overarching research question: '*what do designers need to know?*' suggesting an element of *exploration* and the chronological linking of activities and events within a design project, suggesting an element of *explanation*. Predicting similar results across all three cases led to the creation of the hypothetical integration map, therefore the case study design followed a technique of *literal replication*.

Yin asserts that is imperative that the investigator does everything to ensure that the analysis is of high quality. To do this the analysis should³⁰;

- “*include all the relevant evidence*”: this is supplied via the collation framework in the form of the case study index,
- “*include all major rival interpretations*”: the analysis seeks to establish all the issues surrounding the use of a media type, not just those that ‘fit’,
- “*address the most significant aspect of your case study*”: investigating the questions when to use, what to use and why to use, within the context of using 3D digital media as a communication tool within the design process.
- “*bring your own prior, expert knowledge to your case study*”: with the researcher acting as a reflective practitioner, the purpose of the analysis is to reveal tacit knowledge.

In order to make sense of the data for analysis, it is played with according to some of the construction techniques suggested by Miles & Huberman³¹:

- *Putting information into different arrays.*
- *Making a matrix of categories and placing the evidence within such categories.*

- *Creating data displays, flowcharts and other devices for examining the data*
- *Tabulating the frequency of different events.*
- *Putting information in chronological order or using some other temporal scheme.*

Fig. 27 showed how the action research framework is aligned to established case study methods, utilising multiple cases to develop a method to enable effective cross case analysis. The actual analysis process follows a technique of pattern matching, combined with an element of time series analysis. This technique is appropriate as patterns of activity within the design process revealed by the case study index can be overlaid to establish concurrence across cases. The patterns are matched against the dependent variables: when, what and why. ‘When’ in time the design activity occurred; ‘what’ type of media was used within the activity; and ‘why’ was that type of media used. These variables are consistent across all of the three cases.

4.5.4.1. The Analysis Variables

When: describes each discrete stage of the commercial design process as defined by the activities carried out within each project. Initially defined for each project, the stages are simplified to become common across all studies. Although each case study has a slightly different breakdown each stage comprises of a number of common elements within each stage. This provides a time line against which the events defined by the variables can be established and aligns with the requirements of the chronological time-series analysis technique.

What: describes the media used within each case study. The media types are categorised as being either *digital* or *non-digital* media types. Full descriptions of these media types can be viewed on the CD. Instances of use are only given where there is some form of documentary or visual evidence available in the case study index to support the claim.

Why: describes the reasons why each form of media was used at that particular point in the process. Reasons for use were determined through reflection on how these media had been used within the context of the research case studies as well as in other projects. They were then specifically matched to individual instances of media deployment within each discrete stage of the process. A subset of 'why', is 'who': this variable describes the recipients of the communication utilising the media. Such recipients may be internal or external; internal recipients refer to those within the design team, external to those without.

4.5.5 The Hypothetical Integration Map

The hypothetical integration map was created following the completion of the case study projects, but prior to the collation of case study data, the writing of the case study reports, or analysis of the case study data. The map was created following reflection on the case studies as well as other projects that were being carried out in the Centre for Industrial Design at the time. Its creation represents the first stage in cross case analysis utilising a pattern matching technique where an empirically based pattern is compared with a predicted one³².

Defined through reflection on contemporary events, and developed over a series of iterations, this hypothetical map represents a 2D diagrammatical snapshot of the view within the CfID as to how 3D digital modelling media was being used and integrated into the Centre's design practice. The following section briefly summarises the development of this hypothetical map, a fuller description of its creation and development, including pictorial references, can be found on the CD.



4.5.5.1. The development of the hypothetical integration map

The Structure of the Map

The development of the hypothetical map commenced with a series of hand drawn descriptors of the CfID design process, this was an attempt to try and extract, through a process of peer group discussion and informal reflection on projects, what design

activities were carried out and what media were used on a day to day basis. The first map: Development Map 1 (see CD) illustrated the movement of an idea through the design process, the second: Development Map 2 (see CD) formalised the Centre's commercial design process, which was then simplified to a third iteration: Development Map 3 (see CD), which presented the design process stages as a time line against which media types were arranged.

A list of all media available within the resource base of the CfID, both digital & non-digital was created. A number of reasons were identified relative to the use of each individual form of media at any stage in the design process. These reasons included a number of communication options, e.g. communication to self/peers, communication to client etc. These reasons for use were assigned to each instance of media use set against the time line of the CfID design stages. This resulted in the basic form of the hypothetical map, illustrated by Fig. 28 (& CD), further development simplified this basic map to the simplified map shown in Fig. 29 (& CD) by reducing the design process timeline to a series of stage headings with a number of general activity attributes applied to each stage. The stage headings used here are those used when the hypothetical map was generated; their subsequent development is discussed in section 4.5.7.1.

- Stage 1: Pre-Design – record / generate
- Stage 2: Concept Generation – generate / develop / model / evaluate
- Stage 3: Design Development – develop / model / visualise / evaluate
- Stage 4: Specification – visualise / specify / evaluate

Following further refinement, the final form of the hypothetical map (Fig. 30) was disseminated to a wider audience via conference and journal papers³³. The objective was to make an initial assessment of the validity of the map, both in terms of its content and structure.

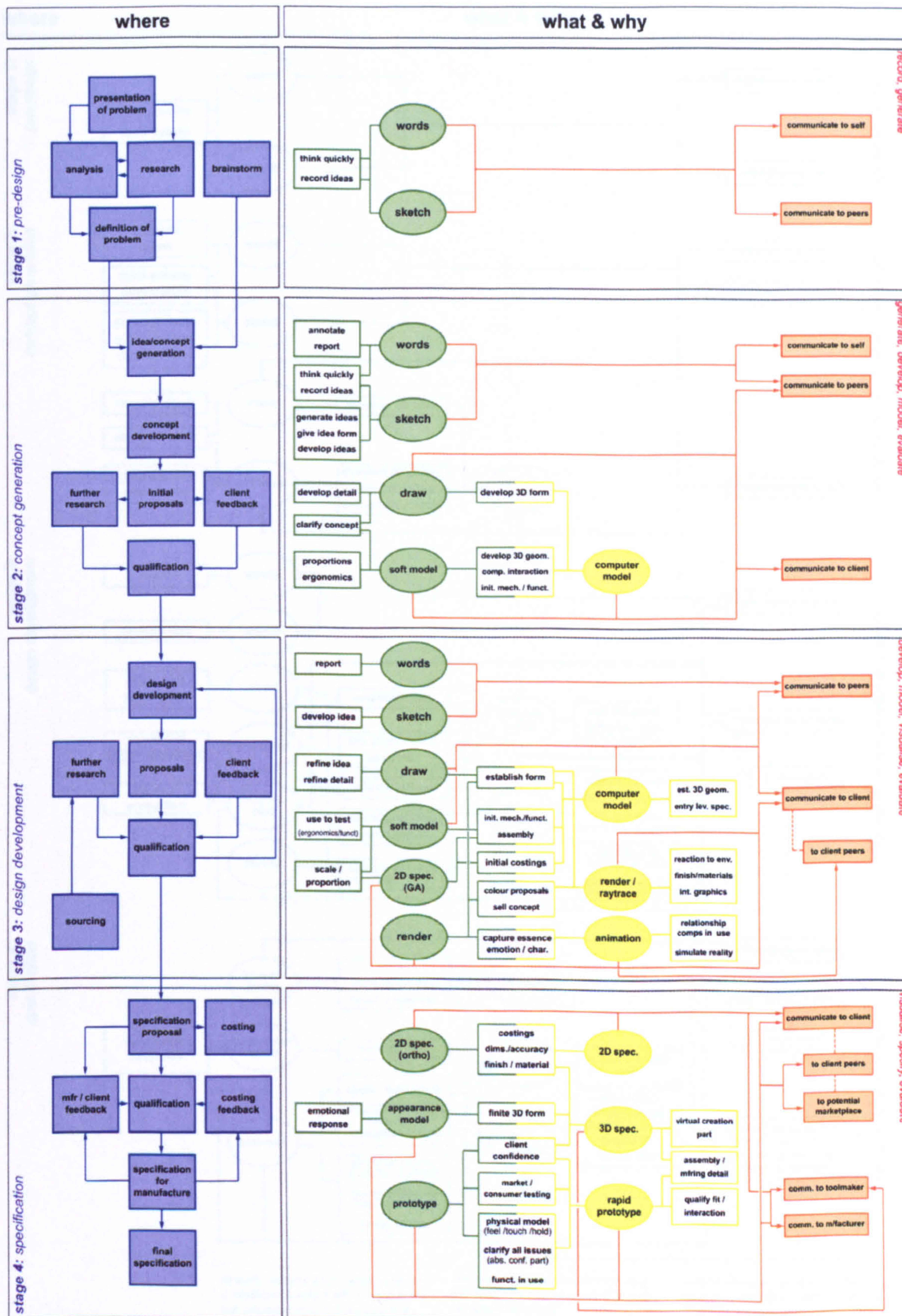
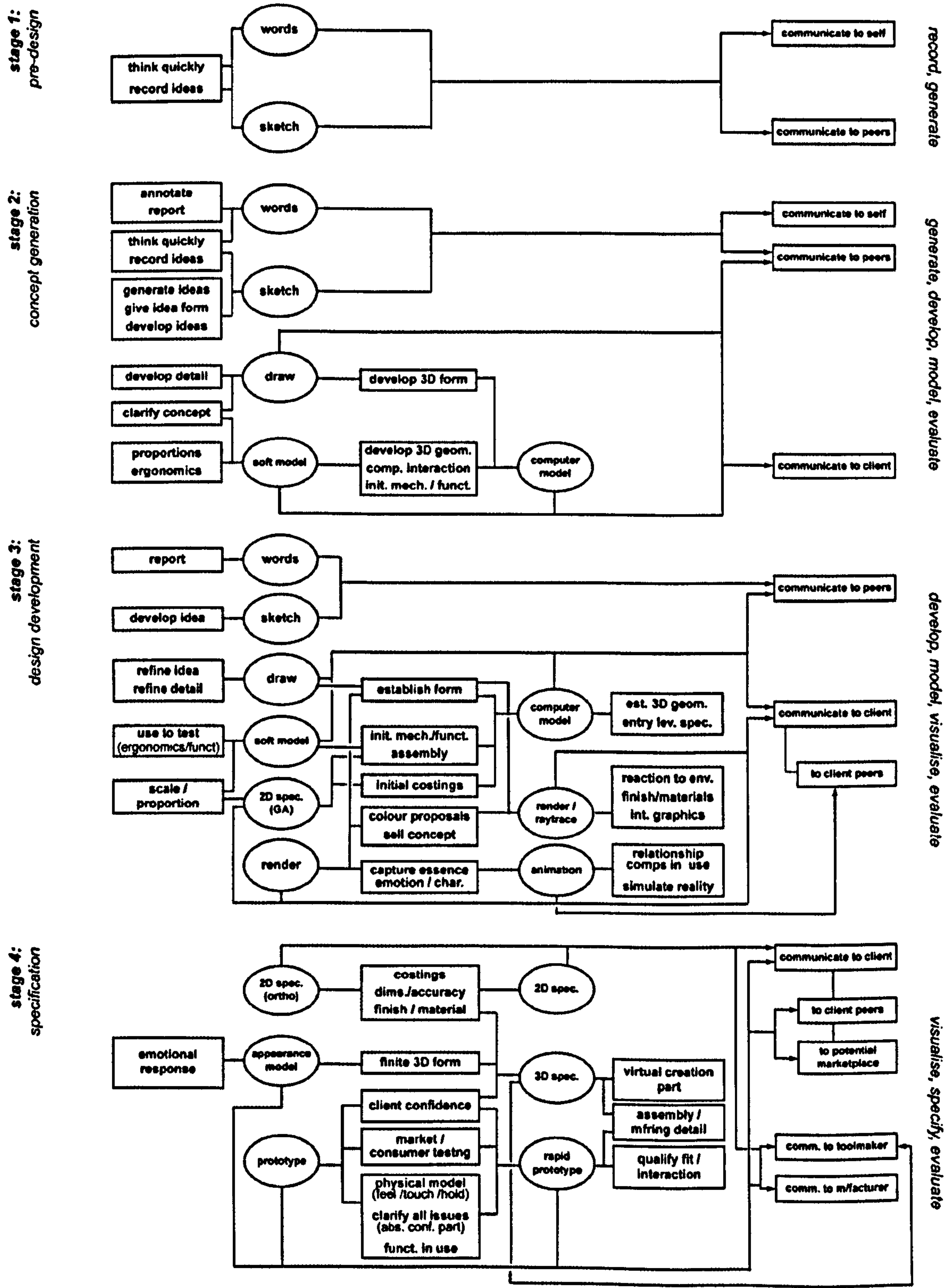

Fig. 28. The basic form of the Hypothetical Integration Map

where

what & why



Specific reasons which relate purely to a traditional medium are mapped to the left, reasons which relate purely to a digital medium are shown on the right, with reasons relating to both shown in a central column.

The overall principal reasons for using a form of media are mapped to individual stages of activity.

Aspects of communication are identified both generally in relation to stages of activity and then specifically in relation to a individual medium.

Fig. 29. The Hypothetical Integration Map – simplified form

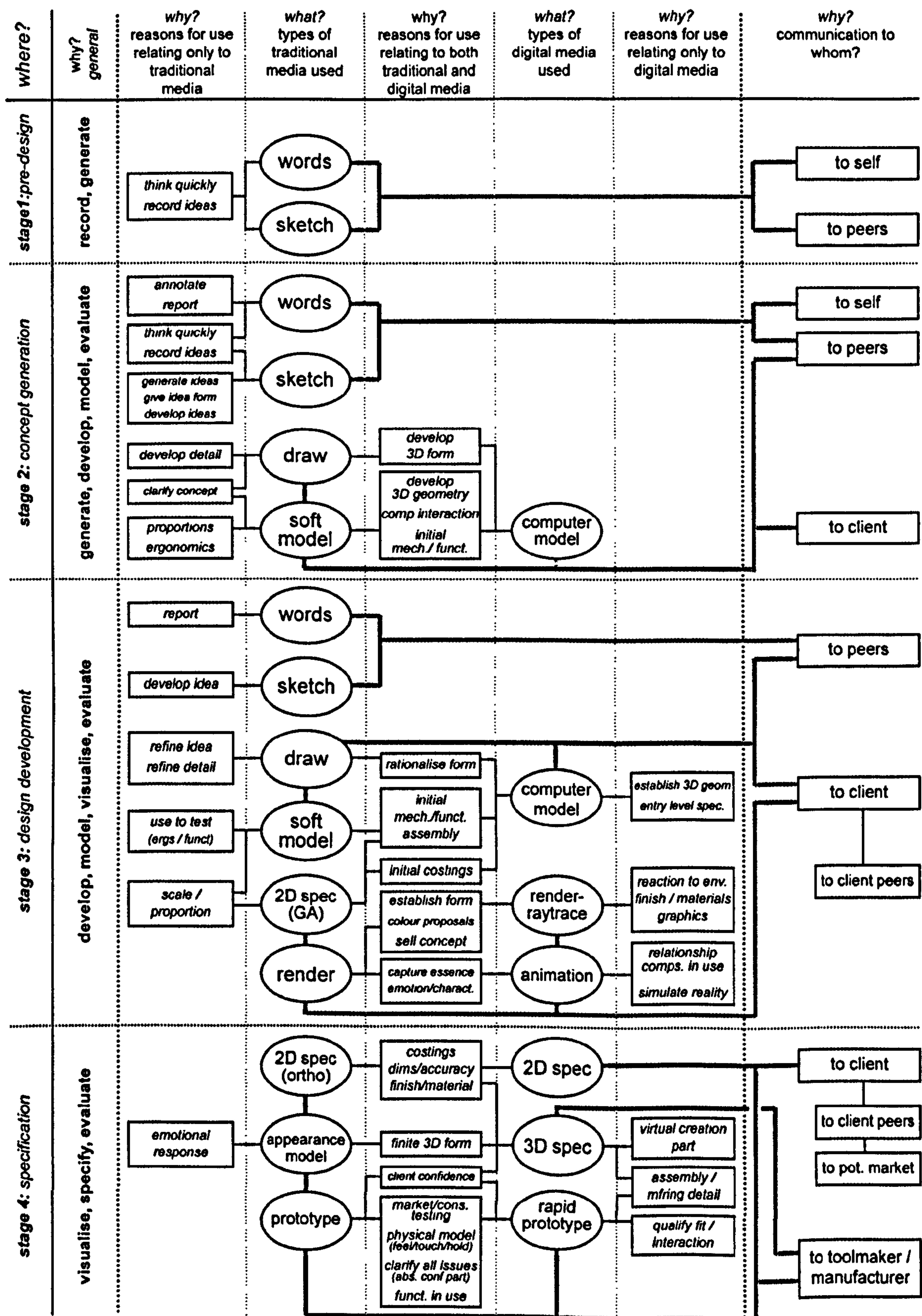

Fig. 30. Final Hypothetical Integration Map

Hypothetical dependent variables

Early in the process of creating this map it had become apparent that there were a number of variables (4.5.4.1) against which the results of the reflection would be presented. These were considered to be ‘*where*’, ‘*what*’ and ‘*why*’ and are defined in the following terms:

- ‘*where*’: represents the time line for the map, the various stages of the commercial design process.
- ‘*what*’: are the types of media that might be used as part of this process.
- ‘*why*’: are the reasons for using these media at various points along the time line. A subset of ‘*why*’ is ‘*who*’, these are the recipients of communication utilising these media.

Alternative hypothetical structures

Following the creation of the map, a number of exploratory exercises were undertaken to map the variables against each other, independent of the time line. The objective of these *Distribution Maps* was to obtain a clearer insight into the findings of the reflection on the case studies. The premise was that through simplification of the viewpoint, findings relative to the use of media may be revealed. However it was found that this was not the case, simplifying the view merely over simplified events to the point that what the maps showed was essentially just a form of received wisdom – they did not reveal anything new. A description of these distribution maps can be found in Appendix 2.6.

4.5.5.2. Outcomes

Following the creation of the hypothetical map, it was possible to see some patterns emerging regarding the strengths and weaknesses of 3D digital modelling media when used within the design process. These patterns became increasingly apparent as the hypothetical map developed, and were revealed through the cross mapping of the hypothetical dependent variables.

The strengths of digital technology appear to lie in its benefit to design activities such as *Design Validation*: providing the ability to interrogate all aspects of the digital model before it is built; *Design Editing*: ranging from changing colour or materials to making detail modifications; *Specification*: enabling the generation of 3D files for model-making, prototyping or tool-making, with the associated production of 2D output; *Prototyping*: the production of accurate working models from computer data, *Communication*: from the use of interactive ‘on-screen’ models to provide a focus for discussion with peers, to the use of ‘photo-realistic’ imagery and animation to convince clients and potential customers of the validity of the design solution.

On the other hand digital technology does have a number of weaknesses, it can be *Restrictive*: lack of user skill or flexibility in modelling tools can lead to a loss of design quality where the computer drives the design, rather than vice versa; *Time Consuming*: building computer models can take some considerable time, as using them efficiently requires an understanding of the advantages and disadvantages associated with their use; *Integrity of model*: the model must be built in such a way as to allow future flexibility; *Lack of Sensory Feedback*: one cannot touch, feel or hold the model; *Processing Power*: especially in areas such as animation, a lack of processing power can compromise what one can afford to communicate.

As a result of this a number of tentative conclusions were drawn:

- Computers are ideally suited to specific, well-defined tasks. It may be inappropriate to use 3D CAD as if it were a blank sheet of paper.
- Digital technologies do not provide a panacea for design practice. The use of media is context specific, i.e. it depends on the nature and demands of the individual design project.
- Digital technologies are better suited to the latter stages of the design process, when more parameters are in place and creativity is not so important³⁴.

- Digital technologies do not replace traditional media; instead they work together to provide a comprehensive design and communication resource.

The dissemination of the hypothetical map through papers and conferences showed that many of the conclusions were essentially no more than received wisdom on the use of 3D digital technologies within the industrial design process. A more rigorous approach was required to fully explore the form that the heuristic map might take and the factors affecting the integration of 3D digital modelling media into the design process. The question of '*what do designers need to know*' had been only partially answered.

4.5.6 Cross Case Analysis

The case study analysis followed a rigorous process which mapped the use of media in terms of the dependent variables defined in 4.5.4.1: 'when', 'what' and 'why'. In the first instance this was done within the context of each individual case study. The data was then layered to establish congruence across the three cases, a process of Cross Case Analysis. The detailed analysis of case study results that follow is based on the pattern matching technique described previously in 4.5.3. Prior to the cross case analysis process however, the information provided by the case studies must be organised in such a way to enable cross case analysis to take place. This is achieved through the definition of first individual, and then simplified individual case study analysis maps.

4.5.6.1. Individual Case Studies – detailed analysis



The first step in the cross case analysis process is to define individual detailed case study analysis maps. This is done in accordance with a process designed to extract specific information related to the use of both traditional and digital media from the case studies. An example of the first stage of the analysis map can be seen in Fig. 31, which also illustrates the application of the definition process described below. The complete individual maps created for all the case studies can be found on the CD. The individual analysis maps are defined according to the following process:

1. Identify the design process stages for the project
2. Identify the general process model that the design project team, including the researcher, followed within the context of the design process stages. This is derived from the index of each case study; this identifies how each of the projects was run and the chronological pattern of events.
3. Identify the forms of visual communication in terms of media type that was used during each of these discrete stages.
4. Identify the reasons for using these forms of communication.
5. Identify the recipients of these forms of communication.



4.5.6.2. Individual Case Study – simplified analysis

In their basic form the individual analysis maps are too complex to be incorporated into the cross case analysis. They must first be simplified so that only the relevant information is displayed; this is achieved via the following process:

1. Replace individual design process models with a generic process model
2. Group the instances of media use within each discrete stage.
3. Group the reasons for use relating to the media type within each discrete stage.

Fig. 32 shows the simplified analysis map illustrating the implementation of the processes described above. All the simplified maps can be viewed on the CD.

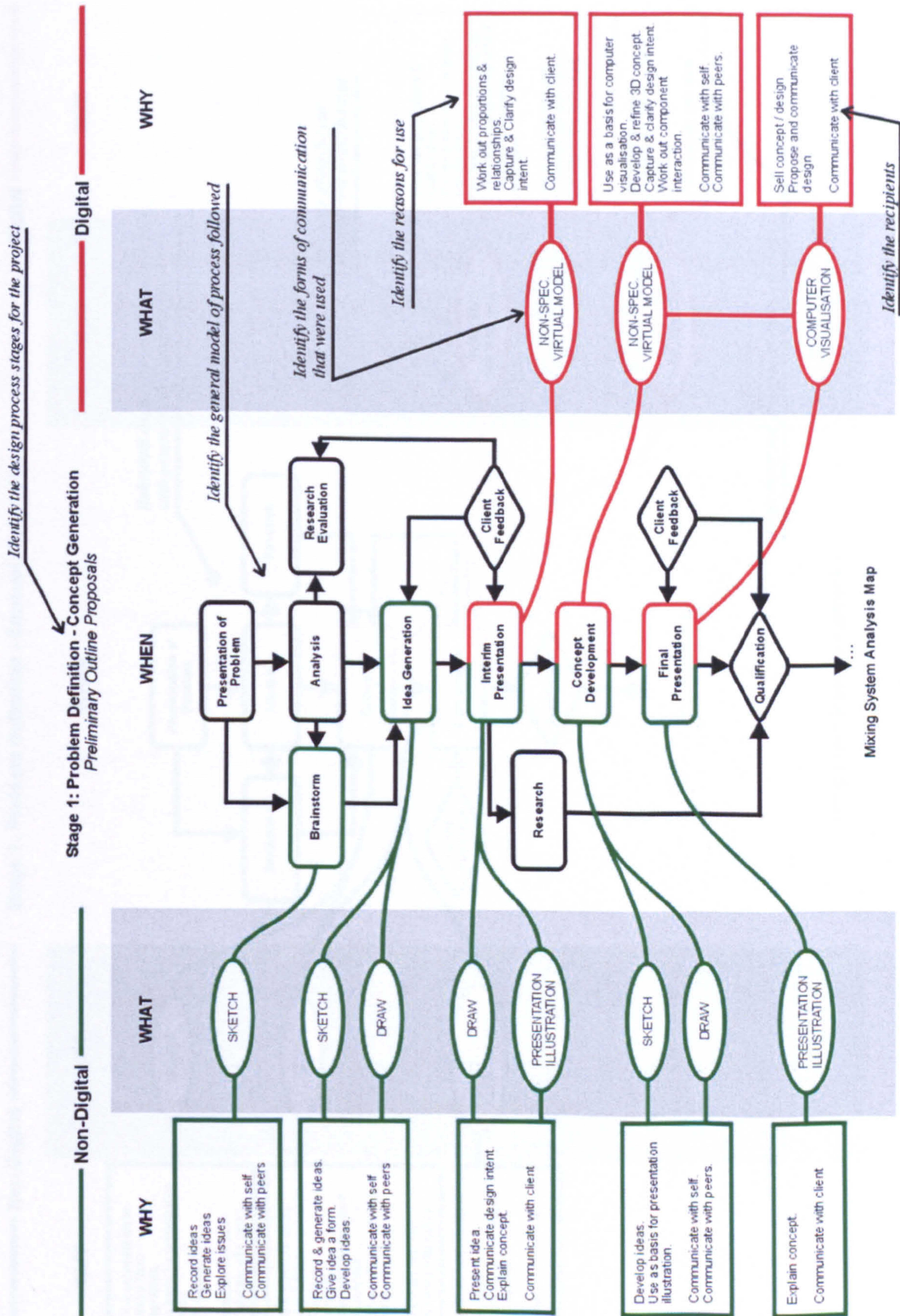

Fig. 31. Stage 1 of the Bi-liquid mixing system individual detailed analysis map

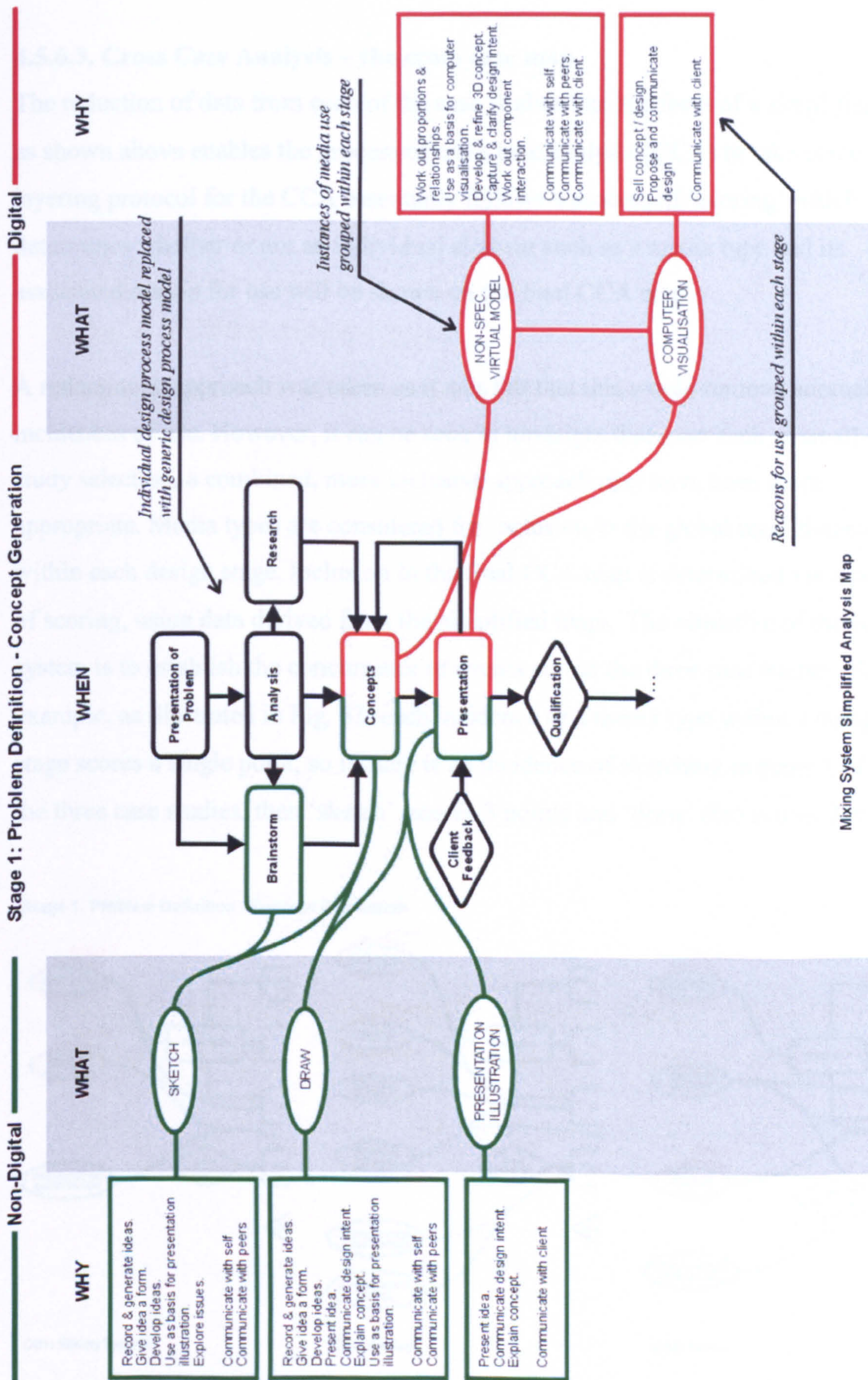

Fig. 32. Stage 1 of the Bi-liquid mixing system simplified analysis map



4.5.6.3. Cross Case Analysis – the cross case map

The reduction of data from each of the case studies into the form of a simplified map as shown above enables the process of cross case analysis (CCA) to take place. The layering protocol for the CCA essentially follows a process of ‘scoring’ which determines whether or not an individual element such as a media type and its associated reason for use will be shown on the final CCA map.

A reductionist approach was taken as it was felt that this would remove anomalous incidences of use. However, it can be seen in hindsight that over such as small case study selection, a combined, more inclusive approach may have been more appropriate. Media types are considered for inclusion in the global map discretely within each design stage. Inclusion in the final CCA map is determined via a process of scoring, using data derived from the simplified maps. The objective of the scoring system is to establish the concurrence of events across the three case studies. For example, as illustrated in Fig. 33, each incidence of a media type within a design stage scores a single point, so if there is an incidence of sketching in stage 1 of all of the three case studies, then ‘sketch’, scores 3 points and ‘draw’ also scores 3 points.

Stage 1: Problem Definition - Concept Generation

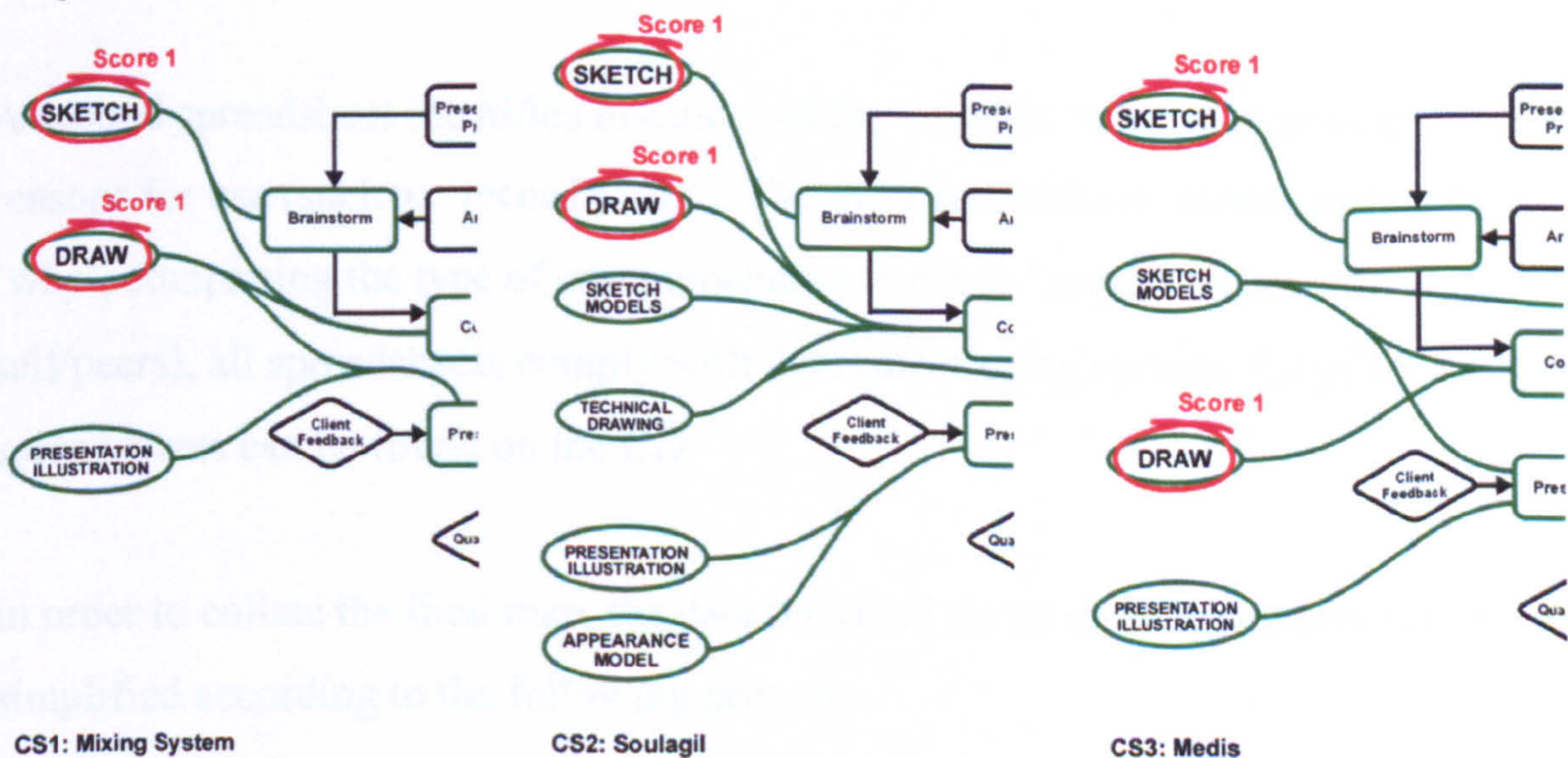

Fig. 33. Scoring system from simplified maps

The intention of the scoring system is to reach a decision as to which forms of media are used within the context of each task. Three spreadsheets collect these scores for each variable within the cross case analysis. The first spreadsheet identifies instances of the variable ‘what’, comprising the media types (such as ‘sketch’ and ‘draw’) within the stages. The spreadsheet collects the scores for instances within both the detailed and simplified maps, this is illustrated in Fig. 34:

CROSS CASE ANALYSIS - detailed

Variable 1: Media Type - WHAT

Media Type	Non-Digital	Digital	Stage 1 Instances	Stage 1 Instances Simplified	Stage 2 Instances	Stage 2 Instances Simplified	Stage 3 Instances	Stage 3 Instances Simplified
Sketch & Draw	●		12	6	4	3	6	3
Presentation Illustration	●		5	3	2	2	0	0
Technical Drawing	●		3	1	0	0	3	1
Sketch Model	●		4	2	5	2	0	0
Prototype	●		0	0	0	0	3	2
Appearance Model	●		1	1	2	2	0	0
Presentation Illustration		●	0	0	0	0	1	1
2D Technical Drawing		●	0	0	3	2	5	2
3D Technical Drawing		●	0	0	0	0	6	2
Non-Spec. Virtual Model		●	3	2	3	2	4	2
Spec. Virtual Model		●	0	0	4	2	5	2
Computer Visualisation		●	2	2	2	2	2	2
3D Animation		●	0	0	1	1	1	1
Prototype		●	0	0	0	0	3	1

Instances of 'sketch' & 'draw' recorded from detailed maps

Instances of 'sketch' & 'draw' recorded from simplified maps

Fig. 34. A spreadsheet collects data re. instances of media.

A second spreadsheet identifies instances of the variable ‘why’, comprising the reasons for use (such as ‘record ideas’). The third spreadsheet records instances of ‘why’, comprising the type of communication (such as ‘communicate with self/peers’), all spreadsheets comply with the same scoring system. All of the CCA spreadsheets can be found on the CD.

In order to collate the final map, the data provided on all three spreadsheets was simplified according to the following process:

1. Remove all instances in all variables with a zero score for the simplified and/or detailed maps, illustrated by Fig. 35 below:

CROSS CASE ANALYSIS - detailed

Variable 1: Media Type - WHAT

Remove all instances with a zero score

Media Type	Non-Digital	Digital	Stage 1 Instances	Stage 1 Instances Simplified	Stage 2 Instances	Stage 2 Instances Simplified	Stage 3 Instances	Stage 3 Instances Simplified
Sketch & Draw	●		12	6	4	3	6	3
Presentation Illustration	●		5	3	2	2	×	×
Technical Drawing	●		3	1	×	×	3	1
Sketch Model	●		4	2	5	2	×	×
Prototype	●		×	×	×	×	3	2
Appearance Model	●		1	1	2	2	×	×
Presentation Illustration		●	×	×	×	×	1	1
2D Technical Drawing		●	×	×	3	2	5	2
3D Technical Drawing		●	×	×	×	×	6	2
Non-Spec. Virtual Model		●	3	2	3	2	4	2
Spec. Virtual Model		●	×	×	4	2	5	2
Computer Visualisation		●	2	2	2	2	2	2
3D Animation		●	×	×	1	1	1	1
Prototype		●	×	×	×	×	3	1

Fig. 35. Refining the CCA data: Step 1

2. Remove all instances of use where both the detailed & simplified score are ≤ 1 . Where the simplified score is 1, but the detailed score is ≥ 2 , the instance may remain, illustrated by Fig. 36 below:

CROSS CASE ANALYSIS - detailed

Variable 1: Media Type - WHAT

Remove all instances where the simplified & detail score are ≤ 1

Where the simplified score is 1, but the detail score is >1 , the instance may remain

Media Type	Non-Digital	Digital	Stage 1 Instances	Stage 1 Instances Simplified	Stage 2 Instances	Stage 2 Instances Simplified	Stage 3 Instances	Stage 3 Instances Simplified
Sketch & Draw	●		12	6	4	3	6	3
Presentation Illustration	●		5	3	2	2	×	×
Technical Drawing	●		3 ✓	1 ✓	×	×	3 ✓	1 ✓
Sketch Model	●		4	2	5	2	×	×
Prototype	●		×	×	×	×	3	2
Appearance Model	●		×	×	2	2	×	×
Presentation Illustration		●	×	×	×	×	×	×
2D Technical Drawing		●	×	×	3	2	5	2
3D Technical Drawing		●	×	×	×	×	6	2
Non-Spec. Virtual Model		●	3	2	3	2	4	2
Spec. Virtual Model		●	×	×	4	2	5	2
Computer Visualisation		●	2	2	2	2	2	2
3D Animation		●	×	×	×	×	×	×
Prototype		●	×	×	×	×	3 ✓	1 ✓

Fig. 36. Refining the CCA data: Step 2.

Executing this process for all the data recorded in the spreadsheets establishes the concurrence of the instances for all of the three dependent variables: ‘when’, ‘what’ and ‘why’. With the data for each of the variables in place, a core cross case analysis

map (Fig. 37) can be constructed which reflects the layering of the data from the three case studies (the full combined CCA map can be found on the CD).

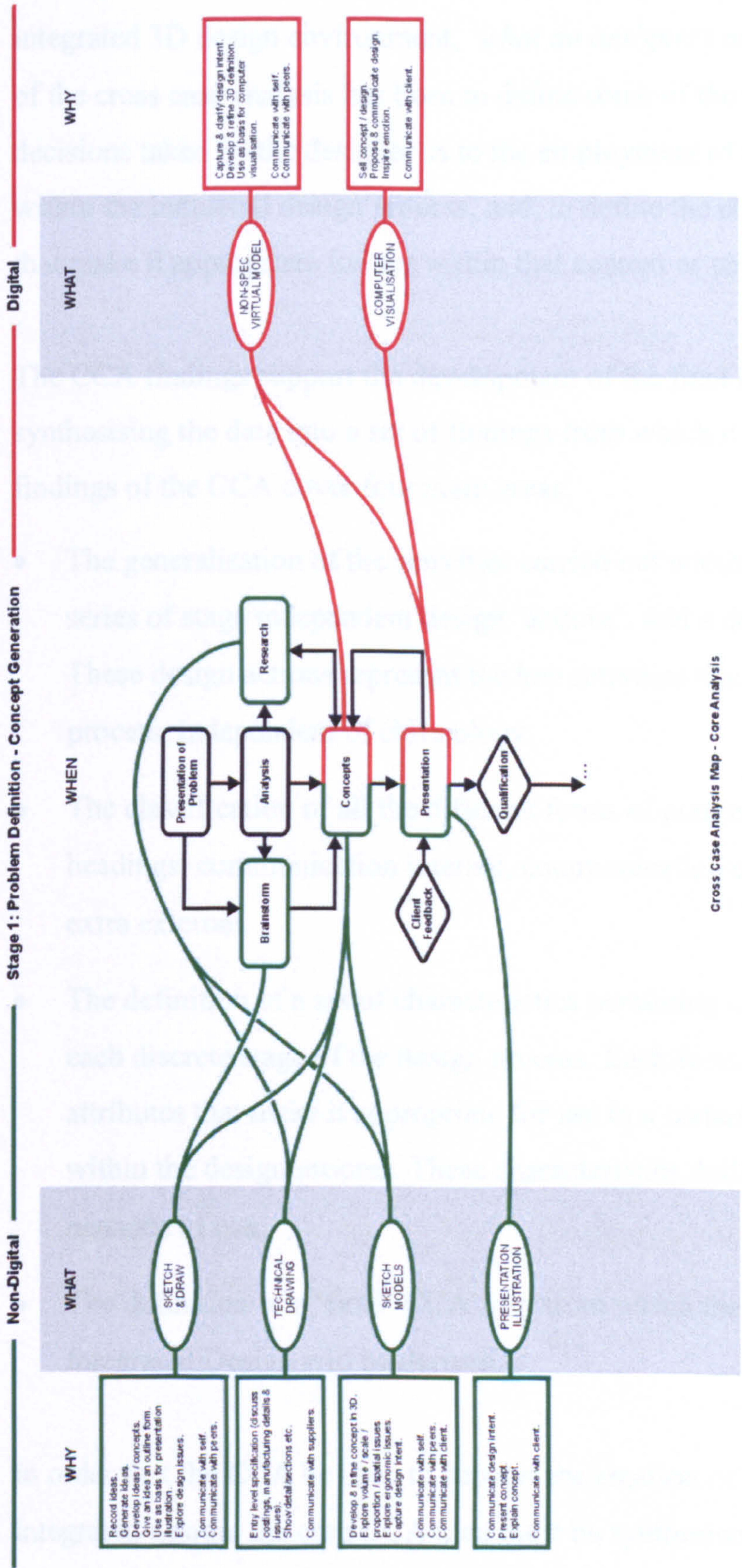

Cross Case Analysis Map - Core Analysis

Fig. 37. Stage 1 of the core CCA map

4.5.7 Cross Case Analysis: synthesis & findings

The key question throughout this thesis has always been: within the context of an integrated 3D design environment, *'what do designers need to know?'* The objective of the cross case analysis has been to define some of the variables affecting the decisions taken by the designer as to the employment of communication media within the industrial design process, and, to define the characteristics of the media that make it appropriate for use within that context or resource set.

The CCA findings support the development of the final heuristic map by synthesising the data into a set of findings from which it will be derived. The findings of the CCA cover four main areas:

- The generalisation of the activities carried out within the design process as a series of stage independent design 'actions', and a definition of those actions. These design actions represent the key activities that occur within the design process, independent of chronology.
- The classification of all the different forms of communication under three core headings: communication internal, communication external & communication extra external.
- The definition of a set of characteristics pertaining to each form of media within each discrete stage of the design process. Each form of media has a set of attributes that make it appropriate for use in a certain way at a certain point within the design process. These characteristics define these attributes for each instance of use.
- The definition of a 'final' CCA map from which the Heuristic Map for Digitally Integrated Design will be derived.

In order that the CCA be used to support the creation of a heuristic map for digitally integrated design, the core CCA map must be synthesised to create a coherent set of findings that will serve to conclude this thesis. As it is shown in Fig. 37, the core

CCA map is still dependent on a timeline. In order to more accurately reflect the iterative and cyclical nature of practice³⁵, it is necessary that the constraint of the time-line be removed. First of all, the CCA data will be rendered time-line independent through the creation of a series of design actions, then the act of communication will be generalised to three categories, and finally a range of characteristics will be defined and allocated to the media types.

4.5.7.1. Adopting an appropriate design process model

Part of the process of research has been in the adoption of an appropriate design model; this serves to establish a form of design process, the main elements of which create the landmarks, or entry points for the heuristic map. In section 2.3 a cross section of design models are described, ranging from the prescriptive models of Archer³⁶ & Jones³⁷, through the descriptive models of Cross³⁸ & French³⁹, to the cyclic theories of Hickling⁴⁰. It is probably true to say that all of these models would claim to have relevance to practice, but do any of them have actual parity with the everyday working practices of the industrial designer?

When the hypothetical integration maps were created, the terminology for the stages of the design process within the CfID were defined as:

- Stage 1: Pre-Design
- Stage 2: Concept Generation
- Stage 3: Design Development
- Stage 4: Specification

When working within the case studies it was found that stages 1 and 2 were often carried out in parallel so these stages were simplified across the three studies to conform to a concurring set of chronologically driven stages defining the ‘typical’ design process carried out within the CfID. These have been defined as:

- Stage 1: Problem Definition & Concept Generation
- Stage 2: Design Development
- Stage 3: Specification & Liaison

As these case studies are based on projects carried out within CfID, it would appear to be appropriate to use a 'typical' CfID design process as a starting point to create a definition, then comparing with alternative constructs of the design process.

Although these definitions are acceptable for outlining the design process stages for client quotations and when reviewing the key development phases of a project, and can be seen to contain the key elements of the design process; such chronological delineations do not adequately reflect the true nature of the design process, as it comprises elements which are both linear and cyclic in nature. The chronological description of the design process described above can be seen to have four key elements:

- Problem Definition
- Concept Generation
- Design Development
- Specification & Liaison

It is accepted that these are the process stages followed within the CfID case studies; however, what had to be established was whether these have any parity with the design process models created by others. Two models from those reviewed in section 2.3 can be seen to have some similarities with the four elements defined above.

French⁴¹ describes the design process as being based on the following set of activities:

- Analysis of Problem
- Conceptual Design

- Embodiment of Schemes
- Detailing

These elements can be seen to have similarities to the four elements of the whirling cyclical model proposed by Hickling⁴², the four elements of which are:

- Shaping
- Generation
- Comparison
- Choice

If we put these into a simple matrix (Fig. 38) then it can be seen that whilst they are not exactly the same, there are significant elements of congruence between the French and Hickling models, which can be translated to the commercial process followed by CfID. The solid lines illustrate the strong congruent links, the dashed the weaker ones.

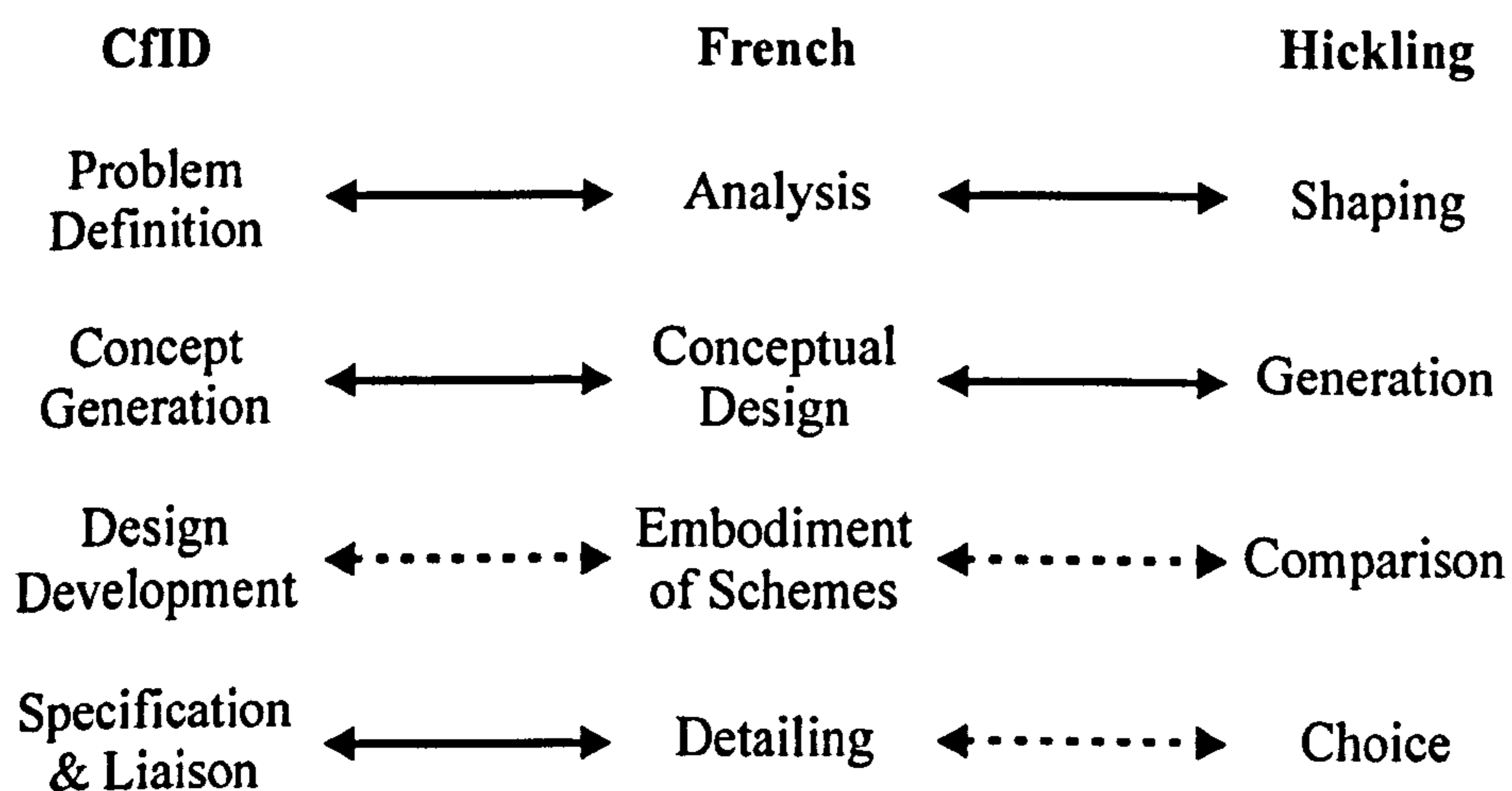

Fig. 38. Matrix illustrating similarities between design process models.

French starts with an initial statement of ‘need’, followed by an “analysis of problem”. Hickling defines the activity of ‘shaping’ as asking first ‘what is the shape

of the problem?', which is followed by a definition of the problem. These can both be seen as similar to the first element of the CfID process: *Problem Definition*.

French's 'conceptual design', Hickling's 'generation' and the CfID's 'concept generation' are all similar in both description and meaning. All refer to the creation of a range of alternative solutions.

It can then be seen that the CfID's 'design development' stage is partially congruent with French's 'embodiment of schemes', which is described thus: "*In this phase the schemes are worked up in greater detail and, if there is more than one, a final choice between them is made.*" This appears to also have some similarities with Hickling, who describes the product of the comparison phase as comprising a choice element "*what makes them different?*" and resulting in "*a set of comparisons and preferences*".

The extent of the final stage of the CfID's commercial process 'Specification & Liaison' is dependent on the nature and scope of the project. In a project such as the Soulagil case study for example, the final deliverable was a specification for costing, whereas in the case of the Bi-liquid mixing system project, the requirement was to manage the process right through to final mouldings. Although French's 'Detailing' activity does not immediately appear to refer to the actual making of the end product, he notes that:

*"This is the last phase, in which a very large number of small but essential points remains to be decided. The quality of this work must be good, otherwise delay and expense or even failure will be incurred; computers are already reducing the drudgery of this skilled and patient work and reducing the chance of errors, and will do so increasingly."*⁴³

Again, with Hickling, his 'choice' phase does not appear immediately to refer anything as concrete as production, as with French it does allude to *implementation*. His 'choice' is defined as a question "*where do we go from here*", followed by "*a decision about policy and action*".

The French & Hickling models are from quite different camps. The French model is based on engineering principles, and is essentially a linear model with some iterative elements; on the other hand, the Hickling model is a whirling cyclic model with no linear aspects apart from that of time. Despite being from such different roots, we can see that both have some congruence to the design process as it is carried out in the CfID consultancy practice.

4.5.7.2. The Creation of Design ‘Actions’

Decisions have to be made frequently throughout every stage of the design process. The types of decisions vary enormously and might be taken by the designer, the designer’s peers, the client, suppliers, client peers or even the eventual user or purchaser of the end product. Some decisions will be taken on the basis of hard facts but within the immediate context of the design process itself the majority of decisions will be taken on the basis of some form of visual representation, image or artefact. These representations, images and artefacts serve to communicate the design content and intent to others in a form that the designer believes will best serve the decision making process and therefore the successful completion of the design process.

In terms of the industrial designer’s decision-making process, the introduction of 3D computing to the core resource set has made the selection of communication media much more complicated. The analysis procedure described in this chapter starts to break down the decision making process in such a way that the factors which affect it might be better understood. Throughout the analysis, the process stages defined in the previous section have been employed to impose a chronological order on events. Chronological accuracy remains important to the analysis but in terms of deriving conclusions from the analysis it is appropriate to move away from the specifics of what is happening at each stage of the process and to look at the objectives of the designer’s activity in more general terms.

In order to achieve this, the various activities carried out within the design process have been grouped into a series of 'actions'. The definition for these actions lies both in the review of the various models which have been devised to try and explain the design process, as well as by looking closely at the activity types carried out within the three design consultancies with which the researcher has had personal experience: The Centre for Industrial Design (where the case studies were carried out), Random Product Design & Alloy Total Product Design.

Studying one's own design process is inherently subjective. The research therefore attempts to find parity between the design process observed and experienced by the researcher in a number of consultancy environments, with that of others. It is for this reason that it was deemed important to study alternative constructs and models of the design process.

A general correlation was found between the commercial stages defined within this research programme, the descriptive design process model defined by French⁴⁴, and the extended whirling model suggested by Hickling⁴⁵ - although each has a substantially different viewpoint, when combined, they have a strong fit to the 'typical' CfID design process. Although the three models illustrated represent differing thinking as to the abstraction of the design process, the definitions of the activities within them are remarkably similar and correlate with the experience of the researcher for the definition of core activities. Drawing on the researchers experience, the matrix was extended (Fig. 39) to derive a number of design 'actions' which it is felt best represent the core activities within the design process, independent of chronological influence. Some draw directly from the models illustrated, others are more derivative, combining elements from a number of models. These 'actions' determine the design process 'model' utilised in the final heuristic map.

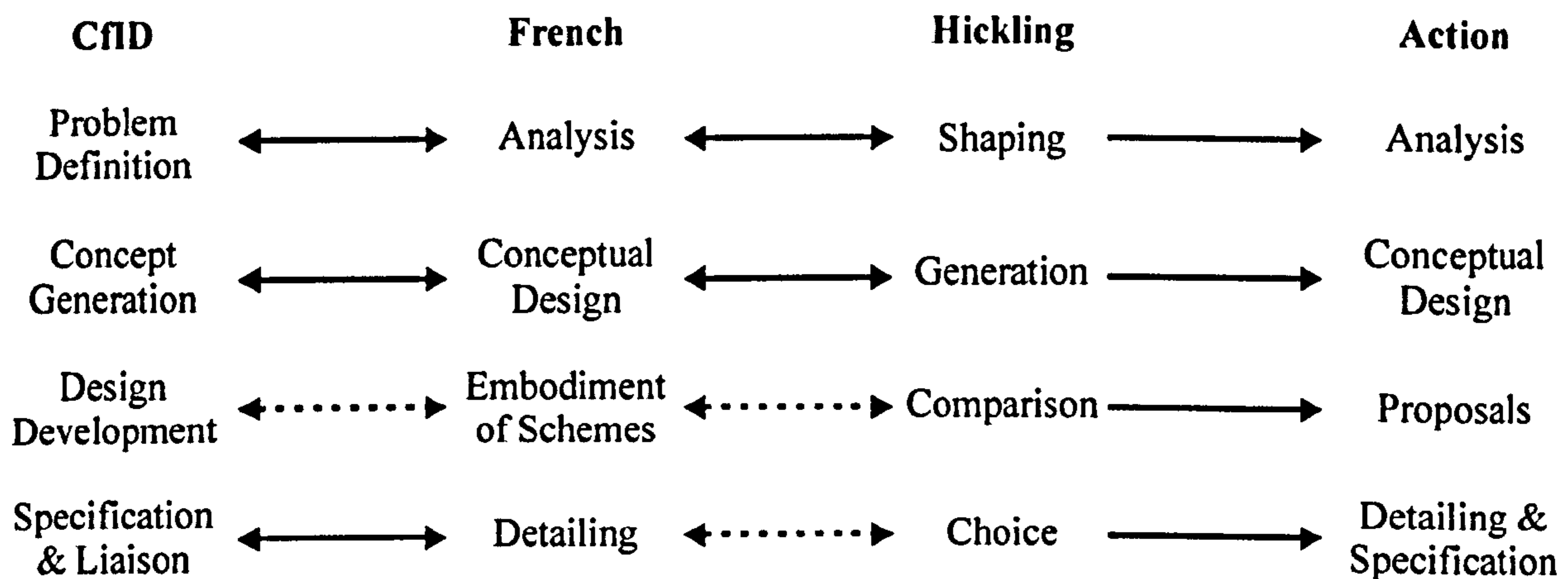

Fig. 39. Extended matrix illustrating derivation of design ‘actions’

It was then considered how designers might best understand these actions, deriving from above what could be terminology understandable to most designers. The ‘actions’ were therefore defined as follows:

1. Analysis

This design ‘action’ seeks to establish objective evidence with regard to issues relating to the design either through the application of judgemental procedures or through exposure of the design or issues to outside parties. This analysis action may take the form of a technical assessment, general research, be part of an early idea generation session, or involve more in-depth activities such as market research or peer review. Analysis can therefore take the form of both internal & external activity and can occur throughout all stages of the design process.

2. Conceptual Design

This design ‘action’ effectively describes the ‘act’ of designing, the creation of a vision or design intent. It covers activities such as brainstorming, concept generation & development. It can happen within any element of the process although it is much more predominant at the formative stages. It is predominantly an internal activity – with the externalisation of conceptual design taking the form of ‘proposals’, although

sometimes a designer might work in conjunction with an external party to help guide the process.

3. Proposals

This design 'action' effectively represents the tangible results of the design process. The action of creating 'proposals' externalises the design activity and presents it in a form that is communicable to others for guidance, feedback or decision-making. Although it is an externalisation of design activity, the action of making 'proposals' can be internal or external in nature, with proposals being presented internally for development or ratification purposes, as well as externally to clients. 'Proposals' may also take the form of a technical proposal to a supplier or manufacturer, who may be the client or a third party.

4. Detailing & Specification

This design 'action' covers the part of the design process where the basic conceptual framework has been agreed but 'flesh needs to be put on the bones', detail needs to be added to render the design complete. The activities of detailing & specification blend almost seamlessly into one another. A designer will detail a design in order to create a specification, that specification may then be used for model making, prototyping, costing and/or manufacture. The early activity tends to be internal with the latter becoming external.

It can be seen that one or more of these actions can be found within each individual stage of the commercial design process. For the purposes of this analysis they are adopted as the core design activities providing the context within which decisions about communication media are made.

4.5.7.3. Generalising the forms of communication

Within the context of the design process there are a range of communication activities, these can be defined within three principal groups:

- *Communication internal*: communicate with self, communicate with peers. Key objectives: to conceive of or develop the design.
- *Communication external*: communicate with client, communicate with supplier. Key objectives: to communicate the design intent in order that a design decision, often between a range of options (client), might be made, communicate information in order to receive guidance or quotations, or, to supply specification data (supplier).
- *Communication extra external*: the client communicating with peers, the client communicating with a potential marketplace. Key objectives: to enable the primary customer (client) to convince their peers or the outside world that the design has merit, principally in terms of commercial viability.

4.5.7.4. Defining the characteristics of the media

The ability to define the characteristics of each form of media within the context of where it was used in the process is a key step in the development of the final heuristic map. In order to help designers find out ‘what they need to know’, the designer/researcher must understand what it was about the media that made it useful to the designer as a tool for communication.

As has been previously discussed, the characteristics of the media are defined through an investigation of the attributes of that media, when used at various points within the design process. The characteristics were defined through a group process, reflecting on the way the various media had been utilised across a range of projects carried out within the CfID (including the case study projects). The group consisted of four people, all with differing roles within the organisation, in order to obtain as broad a view as possible. All had a design role, but also had another key role. The group consisted of the following:

Nick Devitt: Designer & Business Development Manager

Kevin Hilton: Designer & IT Manager

Nina Warburton: Designer & Project Manager

Brian Wilson: Designer & Centre Manager

Dr. Robert Young: Research Supervisor and Research Director

The group considered each form of media and a range of characteristics were applied. This process also served to derive the taxonomy of the media, as there were some areas where one media was dependent on another and the boundaries became blurred, e.g. 3D modelling and visualisation. The results of this session were then collated, the media and characteristics categorised, and the results presented back to the group for verification.

The definition of characteristics followed the definition of ‘core use’ for each form of media. In this context, the term ‘Core use’ refers to the principal or regular use for employing the media. There may be certain uses that a form of media *could* be put to – but for whatever reason they are not. Such uses would not be described as ‘Core Use’. Each form of media is analysed through these reasons of use in order to define the characteristics of the media. The characteristics are therefore limited to those made explicit through the completion of case studies carried out within the programme. However, it is argued that the characteristics are general enough to have relevance to many other areas of industrial design practice. There follows a table Fig. 40 showing the definition of the general characteristics of media:

Fig. 40. Characteristics of media

Media Type: Non-Digital	Characteristics
<i>Sketch & draw</i>	Quick Exploratory Loose Approximate Generative Developmental Descriptive

	Easy to fudge 'real issues'
<i>Presentation illustration</i>	<p>Descriptive</p> <p>Emotive</p> <p>Detailed</p> <p>Possible to fudge 'real issues'</p> <p>Difficult to edit / duplicate</p> <p>Non-variable without re-creation</p>
<i>Technical drawing</i>	<p>Tight</p> <p>Requires interpretation</p> <p>Developmental</p> <p>Proportional & dimensional accuracy</p> <p>Non-emotive</p> <p>Informative</p> <p>Realistic</p> <p>Detailed</p> <p>Difficult to edit / duplicate</p> <p>Non-variable without recreation</p>
<i>Sketch models</i>	<p>3D sketch</p> <p>Quick representation of form</p> <p>Loose</p> <p>Flexible</p> <p>Informative</p> <p>Editable (to an extent)</p> <p>Developmental</p> <p>Non-representative materials</p>
<i>Prototype</i>	<p>Developmental</p> <p>Functional</p> <p>May be aesthetically or non-aesthetically accurate</p> <p>Incorporate real components</p>

	Real scale or accurately scaled
<i>Appearance models</i>	<p>Representative of final product</p> <p>Emotive</p> <p>Accurate</p> <p>Informative</p> <p>Representative of final colour, finish, materials & graphical intent</p> <p>Real scale or accurately scaled</p>
Media Type: Digital	Characteristics
<i>Presentation illustration</i>	<p>Semi-accurate</p> <p>Detailed</p> <p>Representative of form, finish, materials, colour & graphical intent</p> <p>Duplicable</p> <p>Editable</p> <p>Variable – single entity can be the basis for many variations without total re-creation</p>
<i>2D CAD – technical drawing</i>	<p>Tight</p> <p>Developmental</p> <p>Dimensionally accurate</p> <p>Specify finish, materials, tolerances & manufacturing notes</p> <p>Detailed</p> <p>Requires Interpretation</p> <p>Informative</p> <p>Non-emotive</p> <p>Realistic</p> <p>Inevitable inaccurate in transfer of 3D intent to 2D views</p> <p>Requires interpretation by whoever reading drawing</p>

<i>3D CAD – technical drawing*</i>	<p>Derived directly from 3D model, no room for human error in 3D – 2D translation</p> <p>Completely accurate 2D representation of 3D definition</p> <p>Specify finish, materials, tolerances & manufacturing notes</p> <p>Detailed</p> <p>Informative</p> <p>Non-emotive</p> <p>Realistic</p> <p>Consistent</p>
<i>Non-specification driven virtual model (3D CAD)</i>	<p>Non-constrained 3D</p> <p>Flexible</p> <p>Editable</p> <p>Duplicable</p> <p>Informative</p> <p>Explicit</p> <p>Detailed</p> <p>Cannot be used directly as manufacturing data</p> <p>Doesn't give an idea of scale</p> <p>Cannot touch</p>
<i>Specification driven virtual model (3D CAD)</i>	<p>Accurate 3D</p> <p>Engineering & manufacturing accuracy, e.g. draft angles etc.</p> <p>FEA applications – derive properties, e.g. densities, stresses, volumes etc.</p> <p>WYSIWYG (what you see is what you get)</p> <p>Explicit</p> <p>Precise</p> <p>Constrained</p> <p>Parametric</p>

	<p>Informative</p> <p>Detailed</p> <p>Editable</p> <p>Duplicable</p>
<i>Computer visualisation*</i>	<p>Needs 3D model as a basis</p> <p>Time consuming</p> <p>Representative</p> <p>Highly informative</p> <p>Glamorous</p> <p>Can be as realistic or non-realistic as required</p> <p>Duplicable</p> <p>Editable</p> <p>Infinitely variable</p> <p>Accurate representation of materials and finish</p>
<i>3D computer animation*</i>	<p>Time consuming</p> <p>Needs 3D model as basis</p> <p>Informative</p> <p>Glamorous</p> <p>Duplicable</p> <p>Can be as realistic or non-realistic as required</p> <p>Data heavy</p>
<i>Prototype*</i>	<p>Needs 3D model as basis</p> <p>Accurate physical representation of 3D virtual model</p> <p>Quick</p> <p>Mimics reality</p> <p>Duplicable</p> <p>Informative</p> <p>No 'fudging'</p>



4.5.7.5. The Final CCA Map

The characteristics of each form of media were then assessed for each incidence of communication within the individual case studies and the appropriate characteristic elements applied to each individual case study analysis map. The characteristics for each form of media within each discrete stage were then grouped for application to the more general Cross Case Analysis (CCA) map. A 'characteristics' column is added to the analysis to complete the 'final' CCA map. Although the design process stages have been replaced by the design actions, the final CCA map is still divided into a series of stages, this is to ensure that all the data required for the Heuristic Map for Digitally Integrated Design are represented. The complete final CCA map can be found on the CD, an example of it is shown in Fig. 41.

These 'media characteristics', derived through synthesis of the 'core use' data, will serve to form the basis for arguments with respect to the integration of 3D digital modelling media within the final heuristic map.

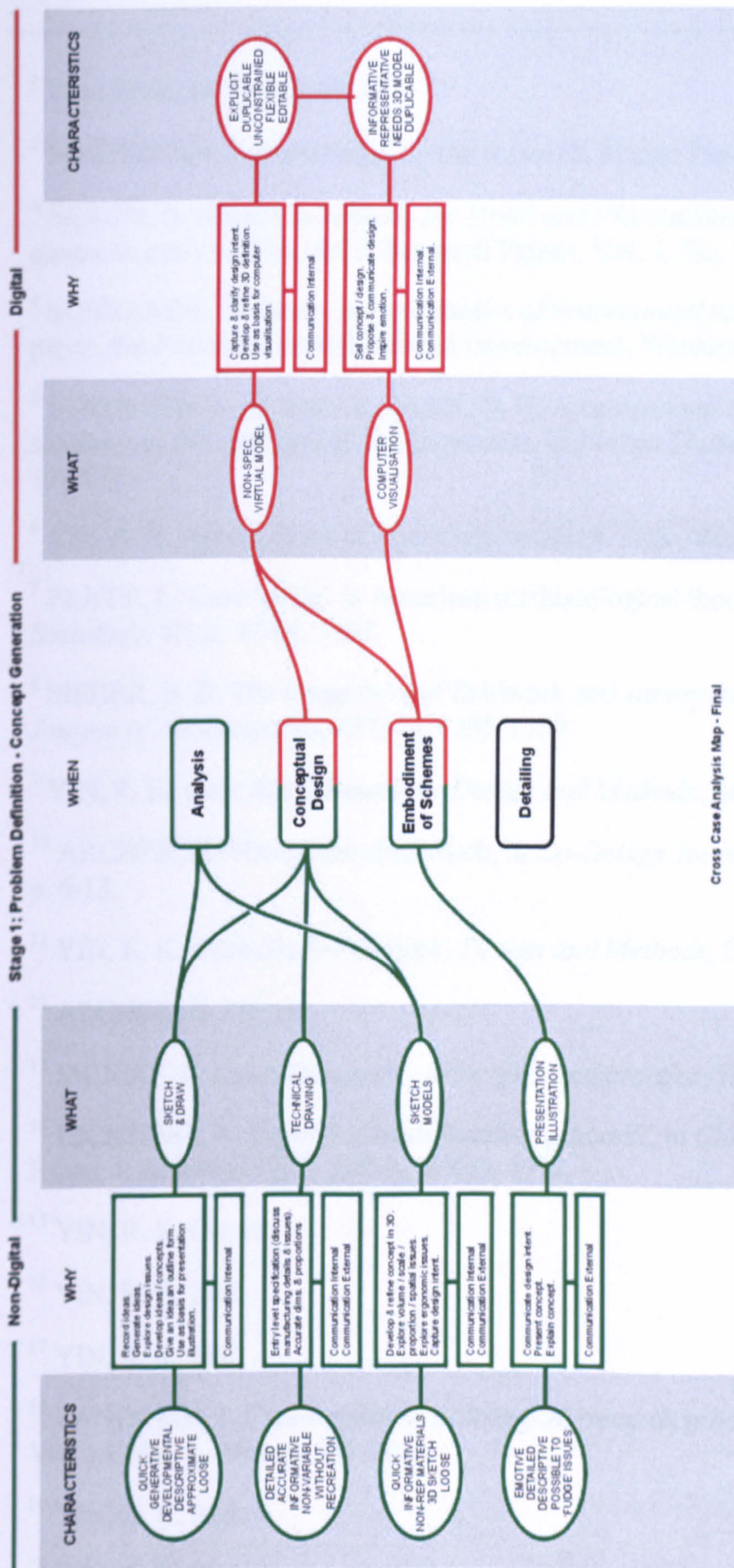

Fig. 41. Stage 1 of the final CCA map

-
- ¹ WALKER, D. Ibid. p. 29-33.
- ² McKERNAN, J. *Curriculum action research*, Kogan Page, London, 1996 (2nd Ed.).
- ³ SEAGO, A. *Research methods for Mphil and PhD students in art & design: contrasts and conflicts*. RCA Research Papers, Vol. 1, No. 3. 1994/95.
- ⁴ SCHRAMM, W. *Notes on case studies of instructional media projects*, working paper, the Academy for Educational Development, Washington DC, 1971.
- ⁵ STAUFFER, L. A., and ULLMAN, D. G. A comparison of the results of empirical studies into the mechanical design process, in *Design Studies*, Vol. 9, No. 2, 1988, p. 107-114.
- ⁶ YIN, R. K. *Applications of case study research*. Sage, Beverly Hills, CA, 1993.
- ⁷ PLATT, J. 'Case Study' in American methodological thought, in *Current Sociology*, 40, p. 17-48, 1992.
- ⁸ SIEBER, S. D. The integration of fieldwork and survey methods, in *American Journal of Sociology*, 78, 1973, p. 1335-1359.
- ⁹ YIN, R. K. *Case Study Research: Design and Methods*, Sage, 1994 (2nd Ed.), p. 4.
- ¹⁰ ARCHER, B. The nature of research, in *Co-Design Journal*, 01.02.03, 1995, p. 6-13.
- ¹¹ YIN, R. K. *Case Study Research: Design and Methods*, Sage, 1994 (2nd Ed.).
- ¹² ARCHER, B. Op. cit.
- ¹³ MCNIFF, J. *Action Research - principles and practice*, MacMillan, London, 1988.
- ¹⁴ HICKLING, A. Beyond a linear iterative process?, in *Changing Design*, (Eds.) B. Evans, J. A. Powell, R. J Talbot, Wiley, 1992.
- ¹⁵ YIN, R. K. Op. cit.
- ¹⁶ YIN, R. K. Ibid.
- ¹⁷ YIN, R. K. Ibid.
- ¹⁸ LANGRISH, J. Case studies as a biological research process, in *Design Studies*, Vol. 14, No. 4, 1993, p. 357-364.
- ¹⁹ YIN, R. K. Ibid.
- ²⁰ YIN, R. K. Ibid.
- ²¹ LANGRISH, J. Op. cit.

-
- ²² YIN, R. K. Op. cit., p. 45.
- ²³ YIN, R. K. Op. cit.
- ²⁴ YIN, R, K. Op. cit.
- ²⁵ YIN, R. K., BATEMAN, E., and MOORE, G. B. *Case studies and organizational innovation: Strengthening the connection*, Washington DC, COSMOS Corporation, 1983.
- ²⁶ YIN, R. K. Op. cit. p. 103-106.
- ²⁷ YIN, R. K. Op. cit.
- ²⁸ TROCHIM, W. Outcome pattern matching and program theory, in *Evaluation and Program Planning*, 12, 1989, p. 355-366.
- ²⁹ YIN, R. K. Op. cit.
- ³⁰ YIN, R. K. Ibid.
- ³¹ MILES, M. B. and HUBERMAN, A. M. *Analyzing qualitative data: a source book for new methods*, Sage, Beverly Hills, CA, 1984, p. 103.
- ³² TROCHIM, W. Op. cit.
- ³³ WARBURTON, N. *Digital Integration & Designer Tactics*. CADE Postgraduate Conference, Coventry University, March 26, 1996. WARBURTON, N. A Heuristic Model for Digitally Integrated Design, in *Co-Design Journal*, 07.08.09, 1996, p. 22-27.
- ³⁴ TEMPLE, S. Thought made visible – the value of sketching, in *Co-Design Journal*, 10.11.12, 1994.
- ³⁵ HICKLING, A. Op. cit.
- ³⁶ ARCHER, L. B. Systematic method for designers. In: N Cross (ed) *Developments in design methodology*, Wiley, Chichester, 1984.
- ³⁷ JONES, J. C. A method of systematic design. In: N Cross (ed) *Developments in Design Methodology*, Wiley, Chichester, 1984.
- ³⁸ CROSS, N. *Engineering Design Methods*, Wiley, Chichester, 1994 (2nd Ed.).
- ³⁹ FRENCH, M. J. *Conceptual design for engineers*, Design Council, London, 1985.
- ⁴⁰ HICKLING, A. Op cit.
- ⁴¹ FRENCH, M. J. Cited in Cross, N. *Engineering Design Methods*, Wiley, Chichester, 1994 (2nd Ed.), p. 20-22.

⁴² HICKLING, A. Op. cit.

⁴³ FRENCH, M. J. Op. cit. p. 22.

⁴⁴ FRENCH, M. J. Op. cit.

⁴⁵ HICKLING, A. Op. cit.

Chapter 5: The Heuristic Map

*“heuristic – adj. Allowing or assisting to discover
map – n. a diagrammatic representation of a route”*

The Concise Oxford Dictionary, eighth ed., 1990.

5.0 THE HEURISTIC MAP

5.1 Introduction

The heuristic map determines the tangible outcomes of this research programme. A *Heuristic Map for Digitally Integrated Design* is presented in the form of an interactive ‘site’ⁱ, published on the UNN website (for peer review purposes), as well as on the CD accompanying this thesis. Presenting the map in this way suggests a method by which the tangible and hopefully useful outcomes of this research programme can be disseminated to the wider design community. The map offers the results of an investigation into the use of 3D digital modelling media within the industrial design process, carried out through the execution and analysis of three case studies at the Centre for Industrial Design. It also accommodates reflections upon insights made during the researcher’s further employment at Random Product Design and currently as a Director of Alloy Total Product Design.



5.2 A Heuristic Map for Digitally Integrated Design

Part of the conclusions to this investigation: ‘*an investigation into the impact of 3D digital modelling media on industrial designers’ internal and external modes of communication*’, will consist of recommendations for how 3D digital modelling and its associated media might be incorporated into the everyday working practices of the industrial designer. There have been a number of key questions that the research programme has sought to clarify:

- How can industrial designers integrate 3D digital media into their design process?

ⁱ Site: see Glossary

- How can industrial designers use 3D digital media to communicate more effectively within their design process?
- When do industrial designers use 3D digital media to communicate within their design process?
- Why do industrial designers use 3D digital media to communicate within their design process?
- What does this tell us about the impact that 3D digital technologies are having on communication within and therefore the execution of design projects?

The central theme of this thesis is appropriate communication, with the premise that within the design process, communication is central to decision-making and therefore appropriate communication is central to effective decision-making.

3D digital media or any other media within the design process is used in order to communicate a thought, action or decision or finding related to the artefact or entity being designed and/or the process of its design. This is especially pertinent to a thesis focused on the issues and factors surrounding the appropriate use of such media within an industrial design context. The appropriate communication of the conclusions has, therefore, always been a key consideration of the thesis. So, what method is the most appropriate and what factors affect the appropriateness of the method?

5.2.1 A model or a map?

Throughout this programme there has been an objective to create some form of ‘tool’ or ‘technique’ which might assist the industrial designer’s understanding of the use or potential use of 3D digital modelling media within his or her practice.

Early in the research programme, references were made to a Heuristic ‘model’ for digitally integrated design. However this would suggest an outcome abstracted from the design process, a theoretical construct created from the findings of research

observation. The execution of the case studies enabled the construction of a hypothetical model, latterly referred to as a 'hypothetical integration map' (4.5.5). An improved understanding of the issues, through feedback from peers following presentation of this 'model' to others via papers and conferences¹, made it clear that what was being presented was not a model, it was not an abstract construct; what was being presented was much more analogous to a map.

The analogy of a map is appropriate for a number of reasons:

- Recording and analysing the case study data is a process of 'mapping' the activities, decisions and actions taken within the execution of each of the case study design projects.
- A map can illustrate the range of potential routes to a variety of destinations; similarly within a design project there are a range of strategies and tactics, which may be employed in order to meet design objectives.
- Maps can provide information on the types of obstacles and landmarks one might encounter when following a particular route. Similarly, when one is following a particular route through a design problem, a map may help the designer to see where the obstacles are, and finds ways around them, or recognise landmarks which may be helpful in understanding the design context.

The map analogy can therefore be seen as an appropriate technique by which information related to the use of 3D digital modelling media might be imparted successfully to industrial designers.

5.2.2 The Map: Objectives

The Heuristic Map for Digitally Integrated Design is the tangible outcome formed as a result of executing the case studies and is the basis upon which the conclusions to the thesis are drawn. The map is created by means of analysing the activities carried out during the execution of the case studies. The results of this analysis are

synthesised in order to generate the Heuristic Map as it is presented on the accompanying CD. The map provides an understanding of how 3D digital technologies might be used within the design process as well as providing a tool that designers can use to navigate through their own implementation & process.

Throughout the thesis there has been a recurring question: “*relative to the use of 3D digital technologies within the industrial design process, what do designers need to know?*”. The Heuristic Map for Digitally Integrated Design suggests a method by which part of that question might be answered. By abstracting the inherently chronological activities that a designer carries out into a number of design ‘actions’, the industrial designer can pursue a line of enquiry relative to that design action. All issues relative to that action should be revealed, without being tied down to a specific point in time. The objective of this would be to generate an understanding of the characteristics of the tools available and the potential issues surrounding their employment.

The Heuristic Map can therefore be seen as a medium for the synthesis of different modes of knowledge, derived from the case studies. The mapping process is used in order to provide understanding and tools for the designer working within industrial design consultancy practice. It is argued therefore, that the technique (for the integration of three dimensional digital modelling media into the industrial design process) is through the implementation of the map.

5.2.3 The Map: Key considerations

However much looping, iteration, spiralling or cyclical whirling² occurs within the design process all commercial design projects follow some form of timeline. The core data for the thesis were based on a series of commercial projects, which inherently have a strong chronological aspect to their process. Therefore, to ensure the rigour of the cross case analysis, the case study data retained its chronological accuracy. However, to generalise the data to industrial design practice required the removal of these chronological constraints.

The nature of a map is such that the reader can choose where to both start and end a journey, entering or leaving the map at any point. The same principles are applied to the heuristic map described here. The objective of the map is to provide information on the media types available within a specific design activity context. Once the media types have been identified, the map provides an insight into the characteristics of that medium and potential reasons for using the media type within the chosen context.

The map provides the information about the media type and its associated attributes. However these are only useful if the user of the map knows where they want to go. The user must therefore understand what type of design activity they are seeking to undertake and to whom they seek to communicate, in order to navigate to the destination. Navigation is achieved via the selection of design actions; *Analysis, Conceptual Design, Proposals and Detailing & Specification*, and communication types; *Communication Internal, Communication External and Communication Ex. External*.

5.2.4 Format

The format for the Heuristic Map is that of an interactive site, charting the characteristics and reasons for using forms of media as they are utilised within the design context. A number of reasons support the site approach as the most appropriate medium:

- The map can be placed on the World Wide Web (WWW)ⁱⁱ, enabling access to interested parties anywhere in the world. This could be for the purposes of peer review and/or dissemination to the design and research communities as a whole.
- The map can be constantly edited, improved and updated to keep it contemporary and up to date with new developments in research and technology.

[#] WWW: see Glossary

- The information presented by the map is complex and multi layered. The attempt to create the initial hypothetical map showed that a 2D approach was a clumsy and inadequate medium through which to present such information. Interactive in nature, the site approach provides a more appropriate, flexible medium through which a large amount of information can be both managed by the creator and presented to the reader or user.

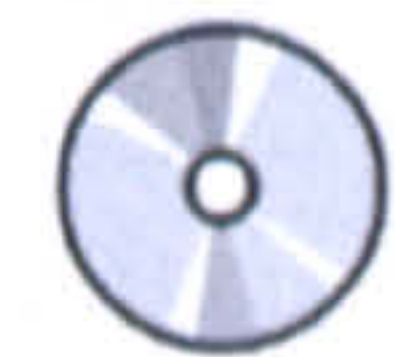

5.3 The Structure of the Map

The map is structured to be as simple as possible to navigate. Navigation choices are limited to that which the user needs to make a decision about at that specific point in time. It is recommended that this section be read in conjunction with the CD. The following diagrams illustrate the basic navigational structure of the map.



Step 1: Select the design activity you are seeking to carry out.

Following the introduction, the user is presented with a selection of four design actions: analysis, conceptual design, proposals and, detailing & specification.

The selection of a design action takes the user to the next screen.

Fig. 42. The first step in navigating the map is to select a design action

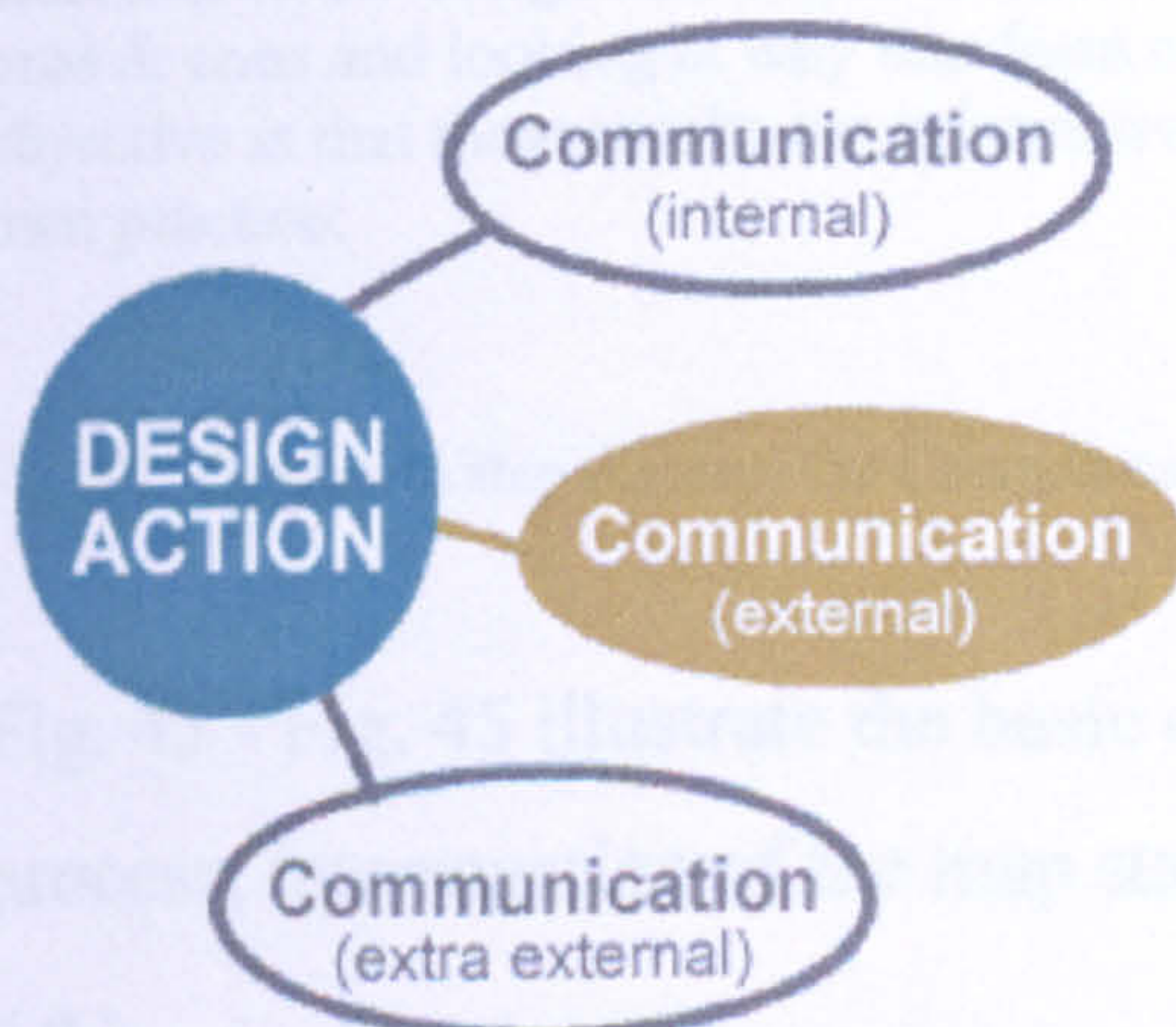

Step 2: Select who you are communicating to.

The user is presented with a selection of three communication options: communication internal, communication external and, communication extra external.

The selection of a communication type takes the user to the next screen.

Fig. 43. The second step is to select a communication type

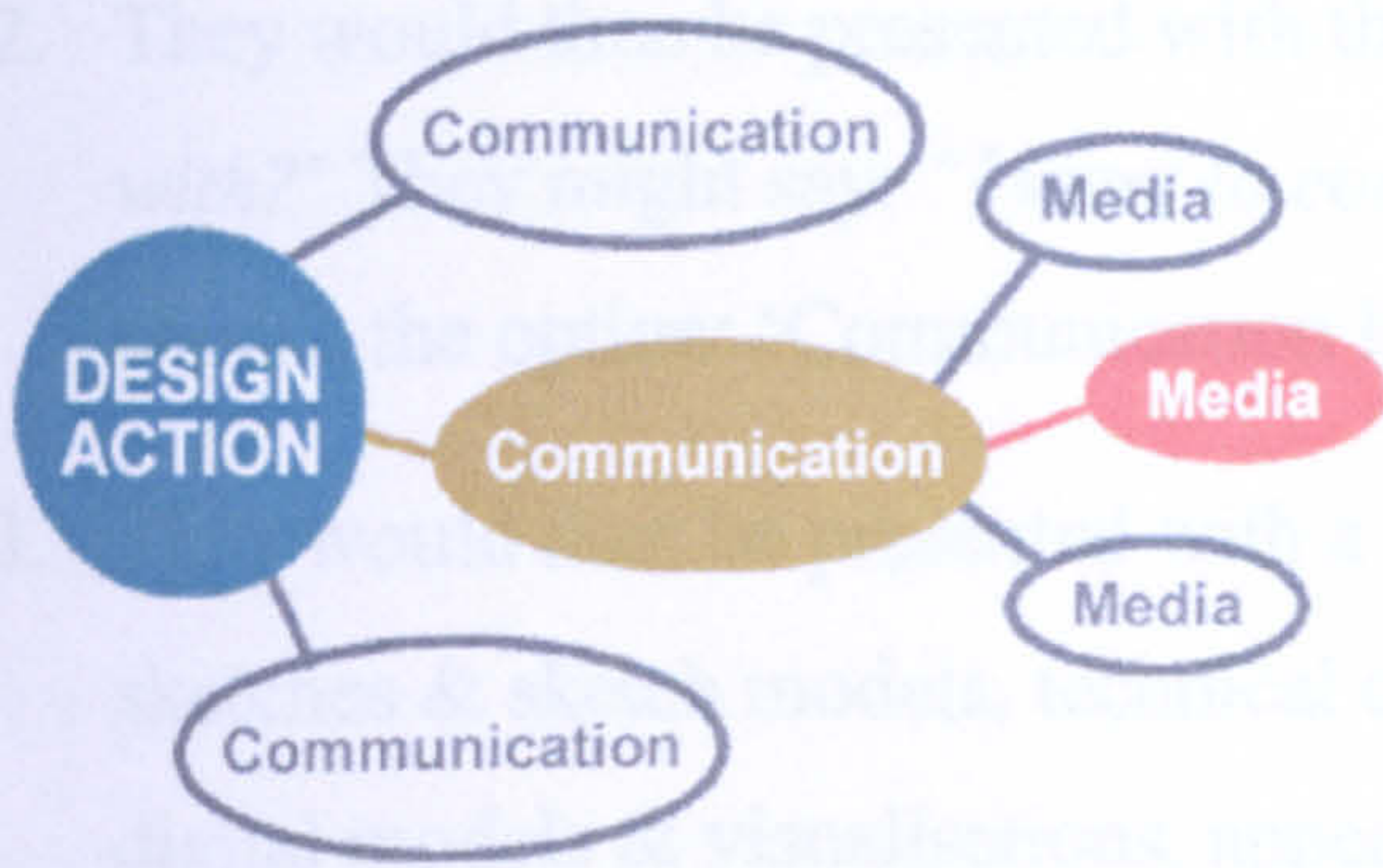

Step 3: Select a media type you wish to investigate

Media Types are split into four distinct categories:

- Non-Digital 2D Media*
- Non-Digital 3D Media*
- Digital 2D Media*
- Digital 3D Media*

Digital Media are shown in red, Non-Digital Media are shown in green.

Fig. 44. The third step is to select a media type available for that action and that communication type

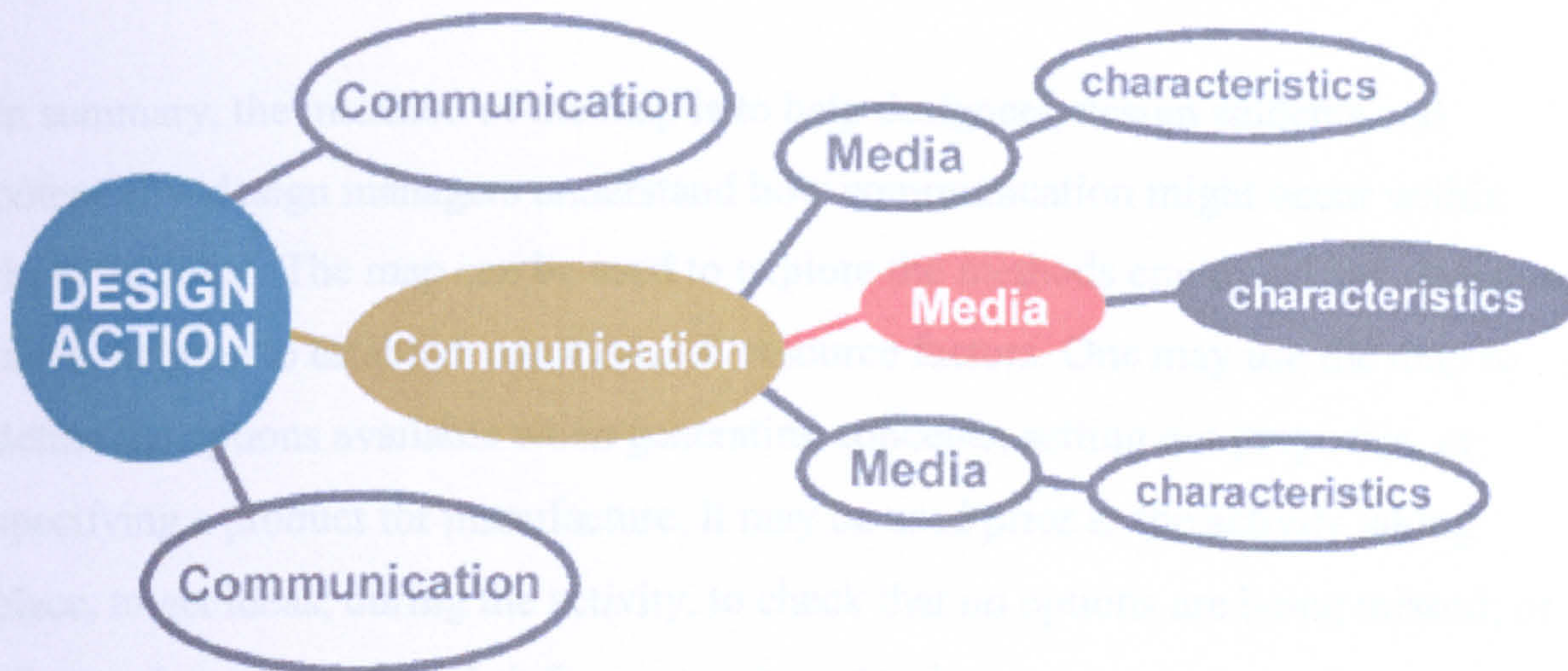

Step 4: Display the Characteristics and Use Summary

The characteristics & use summaries are the real meat of the map. The characteristics define what makes that media appropriate or inappropriate for use within the specific context of use defined by the selection of the design action and communication type. The use summary adds weight to this, defining pros & cons and looking at why that form of media might be used at that particular time. The objective is that these results are informative that others can use them to benchmark or inform their own practice.

Fig. 45. The fourth step displays the Characteristics and Use Summary (illustrated in Fig. 46)

Fig. 43 - Fig. 45 illustrate the basic core structure of the map. Stepping through the process, interrogation of the map starts with an identification of the design 'action', e.g.:

1. A designer might say: "I want to present my concepts". They would then choose the design action: 'Proposals'.

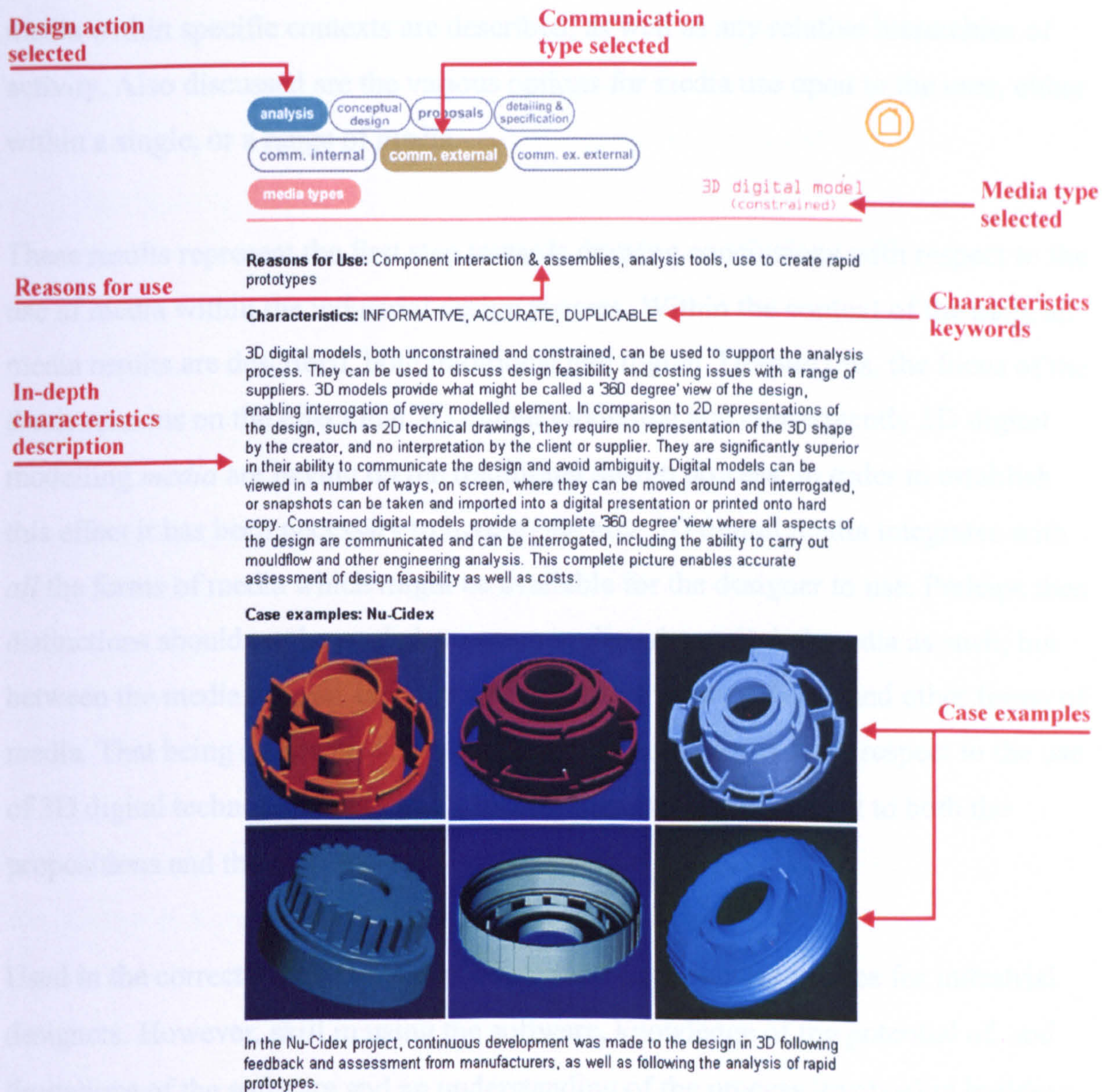

Fig. 46. An example of a Characteristics and Use Summary page within the Heuristic Map

The definitions as illustrated above are extensive and for reasons of length are not described here, the core findings are shown in detail within the context of the interactive map itself, and can be found on the accompanying CD.

These media descriptors define the pros and cons for using each form of media within the action context. The relationships between different forms of media are discussed in the characteristics description. The benefits of using certain forms of

2. They would then be presented with the query: *'Whom are you communicating with?'* They might say: *"I want to communicate to my client"*, they would then choose the option: 'Communication External'.
3. They would then be presented with a range of media options, these might include: sketches & sketch models, technical drawings & presentation illustrations, 3D digital models & visualisations, appearance models & prototypes.
4. The selection of one of these media types would result in the display of a use summary and characteristics associated with the media type.

In summary, the intention of the map is to help designers, design students and potentially, design managers understand how communication might occur within these 'actions'. The map can be used to explore the methods employed and decisions taken, helping to establish contextual & resource factors. One may use the map to define the options available when generating concepts, setting out proposals, or specifying a product for manufacture. It may be used prior to the activity taking place, to get ideas; during the activity, to check that no options are being missed; or afterwards, as part of a debriefing or 'post mortem' exercise.

5.3.1 The core results of the heuristic map.

Following the execution of the formative case studies (2.6.4) a set of propositions were made in which it was suggested that a number of factors might affect the integration of 3D models into the design process:

- **Integrity *versus* Flexibility**, i.e. the integrity of the construction path may affect the future flexibility of the model.
- **Interpretation *versus* Clarity of Presentation**, i.e. the mode or method of presentation may affect interpretation of form, finish, complexity and project progress.
- **Appropriate use of Model *versus* Design Development**, i.e. the decision to use computer modelling may affect the development of that design.

- **Clarity of Communication *versus* Decision Making, i.e.** decision making may be affected by the clarity of communication

These factors are very specific to the actual creation of 3D digital models, originally the main focus of the research study. A focus shift to the use of 3D digital media as a communication tool deemed it necessary to establish whether these factors had concurrence with practice and consequently any wider relevance to the use of 3D digital technologies as a facilitator for communication and decision-making.

Following the creation of the Hypothetical Integration Map a number of outline conclusions were drawn with respect to the strength and weaknesses of 3D digital technologies as used within the context of the design process. 3D Digital technologies were found to be strong in terms of:

- *Design Editing*
- *Design Validation*
- *Prototyping*
- *Specification*

These rely heavily on the strength of 3D digital technologies as a tool for communication, whether that communication is within, or without, the design team. They were also found to have a number of significant constraints, primarily:

- *Restrictions due to the skill base*
- *Investments in time*
- *Model integrity*
- *Lack of sensory feedback*

The tangible results of the map are represented in the form of a number of media descriptions, illustrated in Fig. 46. The information presented in these descriptions fall under three headings:

- *Reasons for use*
- *Characteristics*
- *Case examples*

‘Reasons for use’, are represented by a number of key phrases, which describe the use of that media within the context of the design action and the communication type being considered, e.g. the reasons for using a constrained 3D digital model during an analysis action and communicating externally might be; *Component interaction and assemblies, Analysis tools, Use to create rapid prototypes*; these reasons for use are derived directly from the cross case analysis map.

‘Characteristics’, are represented by a number of keywords, also taken directly from the cross case analysis map. These are the general attributes of that media which make it appropriate for use at that particular point in the process, e.g. the keywords of the characteristics of a 3D digital model during an analysis action and communicating externally might be; *Informative, Accurate, Duplicable*; and are followed by a fuller explanation of the characteristics of the media.

‘Case examples’, gives illustrations for the use of the media at the particular point in the process. Within this thesis, these case examples are taken only from the three case studies, ideally however, future iterations of the map would be broadened to accommodate case examples from a range of sources.

media within specific contexts are described, as well as any relative hierarchies of activity. Also discussed are the various options for media use open to the user, either within a single, or a range of media.

These results represent the first step towards drawing conclusions with respect to the use of media within the industrial design process. Within the context of the map, all media results are described, both traditional and digital. Despite this, the focus of the thesis remains on the effect that 3D digital modelling and consequently 3D digital modelling *media* are having on the traditional design process. In order to establish this effect it has been necessary to investigate how 3D digital media integrates with *all* the forms of media which might be available for the designer to use. Perhaps then distinctions should not be made between non-digital and digital media as such, but between the media derived as a result of the use of 3D modelling, and other forms of media. That being said, what wider conclusions can be drawn with respect to the use of 3D digital technologies as a tool for communication with respect to both the propositions and the map results?

Used in the correct way, 3D CAD can provide a core digital resource for industrial designers. However, skill in using the software, knowledge of the potential of, and limitations of the software and an understanding of the process involved in building digital models are essential. Such an understanding is not only essential in the direct management of the digital resource but in the management of that resource as an integral part of the design project.

3D CAD is a tool that allows designers to express their creativity; it allows the exploration of form and spatial awareness to a degree that may have been impossible by other means. It provides a level of accurate visual feedback invaluable to the essential communication processes contributing to the development of a design between the designer and themselves and the designer and their peers. It is a vital tool for the communication and understanding of 3D form.

3D CAD has given industrial designers more power over the process, accompanied by a stronger sense of responsibility but also a higher workload. Creating data that is to be used directly for tooling makes the designer more responsible for the end product, requiring them to be absolutely sure that the data is correct. It also gives them more work to do, as designers using 3D CAD for tooling have a greater involvement later in the process.

3D CAD enables the creation of a range of 3D Digital Media. 3D media provides a far richer form of communication than 2D media. Once a 3D model is created it can provide a range of universal deliverables that enable communication to all parties relevant to the process. These universal deliverables can take a range of forms, from viewing and interrogating a 3D model on screen in an informal manner, through to the creation of photo-realistic images of a product to be used to convince a client or other party as to the viability of the proposal, to providing accurate data ready for manufacturing direct to engineers or tool-makers for analysis or the production of tools. This range of universal deliverables is an invaluable addition to the arsenal of the modern industrial design practice.

All software has limits and not all 3D software can provide the whole gamut of capabilities summarised above, however if we look at 3D in terms of its 'potential' for communication, we can see that 3D digital media has significantly greater 'communication potential', than any of the traditional media or even 2D digital media. For the foreseeable future it can be seen that some traditional forms of communication such as sketching and sketch modelling remain essential, quick and useful tools ideal for matching the speed of the thinking processes of the industrial designer. Sketches are quick to create, the feedback that they give is short lived, they are used and discarded and the designer moves on, one might then say that they have a low 'communication potential'. On the other hand, although the time taken to create a 3D CAD model is much longer than the time taken to create a sketch, it is continually editable, modifiable and duplicable, and offers a wide range of

deliverables. It might then be said that the 'communication potential' of a 3D CAD model is very high.

In 1992, during the embryonic stages of this programme, there was significant concern that in ten years time 3D technologies would have changed so much that any study with that as its focus would be obsolete, this has not been the case, although there have undoubtedly been changes; the software has become more sophisticated, usable and refined, with more options than ever of which one to use. But in the researcher's experience, working within an integrated 3D CAD environment within three companies, the *fundamental* reasons for using it and the decisions regarding its use have not altered by any significant degree. There are always new technologies raising new challenges, but in essence the core strategies for the use of 3D CAD and its associated technologies appear to remain remarkably unchanged.

This may be partially explained by the fact that although 3D CAD is now effectively an industry standard within industrial design, tool making and manufacturing, there are still some industrial design consultancies that still do not have a 3D CAD resource. Further, many of those that do have it, are using unconstrained modellers such as Alias, which cannot be used to specify directly for manufacture, the use of 3D CAD is therefore ending at the creation of a pretty picture, rather than *directly* usable data.

5.3.2 Peer Review

The map was given an element of external assessment by undertaking an external review by the researcher's peers, both within the academic and commercial design worlds. The limitations of the map are acknowledged and expressed later in this chapter. Part of the objective of presenting the map as a site is to enable this peer review in order to establish a minimum level of objectivity. Concerns as to the potentially subjective nature of case study research material are well documented³; externalisation is necessary in order to build on the objectivity established through the use of the case study analysis techniques. The peer review was enabled via the

Internet, through placement of the map on the UNN website, subscribers to a number of industrial design discussion listsⁱⁱⁱ were invited to view and comment on the map. A short on line questionnaire was provided to formalise the feedback.

The website route was appropriate as the time pressures on the researcher are considerable (the demands of being a director of a design consultancy), leaving little time available to carry out peer review on an involved and personal level. With the researcher also an active design practitioner within a commercially driven design consultancy, it was recognised that there might be a significant confidentiality barrier in talking directly to designers from other consultancies about their process. It is believed that the ability to comment anonymously and remotely overcomes the majority of these confidentiality issues.

5.3.2.1. Qualifications

The peer review is intended only as a receptivity check for the map. The principal intention to determine a peer group response so that its basic validity might be determined and suggestions made as to its improvement and future development. The peer review and questionnaire were essentially a means of obtaining quick, informal feedback that would give a first impression of how these sort of findings might be viewed by the design profession.

The request for reviewers was made through three email discussion lists: IDForum, the Design Research Society Discussion List and the PhD-Design Discussion List. As respondents replied directly, it is impossible to tell from which of these lists the responses came. Some reviewers were also contacted directly, however, the short timescale did not allow time to follow-up reviewers who did not respond immediately.

ⁱⁱⁱ Discussion lists: see Glossary

5.3.2.2. Feedback

The review obtained 10 responses, which, when considering the time available, was a good response. The questionnaire was sent out and responded to via email.

There were some criticisms of the map, many of which have already been made by the researcher. There was a concern that perhaps the data needed to be a little more contemporary, and should include the more recent developments in 3D software, new media technologies and hybrid 2D/3D technologies such as Studio Paint (a digital sketching package). It is accepted that with more development the map could become a much more sophisticated and intuitive tool, perhaps incorporating hot links to new and emerging websites. There was also some criticism of the graphical representation, one respondent not understanding the different graphical representations for traditional and digital media; some respondents did not immediately find the help site. These are concerns that the researcher shares and are issues that could undoubtedly be resolved with further development.

The responders came from a good cross section of the design profession and included academics/researchers, practitioners and design managers, no students responded. Most respondents found the map relatively easy to navigate and all had positive comments to make regarding its contribution to design knowledge. All of the reviewers had some experience of using 3D CAD. Two of the respondents thought that the map had relevance to commercial design practice, but by far the overall consensus of opinion was that the map had very strong relevance to students or designers just starting out. It was felt that it provided a good basis for understanding design practice and why, when and where the various tools might be used. Three of the respondents suggested that they could see a use for the map directly as a teaching tool.

5.3.2.3. Findings

In all, the response to the map was very positive, it was generally viewed as a positive means by which to communicate the information and a valid way of

disseminating research. Although considered, the teaching aspect had not been a key part of the original intention but is a welcome result. If this research can help to understand the use of digital tools and presents a means by which such information can be presented, then this provides a platform for further investigation and development by others. More work would certainly need to be done to establish how to provide a tool that was of greater use to practicing designers.

Some suggested scenarios for use therefore might be:

- A student wanting to learn more about how the digitally integrated design process operates.
- A designer working within a new project context, e.g. working in an area they have no previous experience in.
- A designer has just learned how to use a 3D CAD tool and wants to see how it might be used.
- A designer wants to look at their process and validate it.
- A designer or design manager comes into contact with 3D CAD for the first time.

¹ WARBURTON, N. *Digital Integration & Designer Tactics*. CADE Postgraduate Conference, Coventry University, March 26, 1996. WARBURTON, N. A Heuristic Model for Digitally Integrated Design, in *Co-Design Journal*, 07.08.09, 1996, p. 22-27.

² HICKLING, A. Beyond a linear iterative process?, in *'Changing Design'*, (Eds.) B. Evans, J. A. Powell, R. J Talbot, Wiley, 1992.

³ WALKER, R. *Three good reasons for not doing case study research*. Paper presented at the annual meeting of the British Education Research Association at Crewe and Alsager College of Education, Cheshire, September 1981., & MILES, M. Qualitative data as an attractive nuisance: The problem of analysis, in *Administrative Science Quarterly*, 24, 590-601, cited in: STAKE, R. *The Art of Case Study Research*, Sage, 1995, p. 45.

Chapter 6: Conclusions

“I want us all to find better ways to engage in productive collaboration and enhance our design capability with new media by enabling the creative use of digital tools.”

Mark Von Wodtke, Design with Digital Tools, McGraw-Hill, 1999, p. xi.

6.0 CONCLUSIONS

6.1 Introduction

As the title: '*An investigation into the impact of 3D digital modelling media on industrial designers' internal and external modes of communication*', suggests, this thesis has studied the effect that the introduction of 3D digital modelling has had on the way industrial designers communicate. The inclusion of 3D digital modelling into the designer's toolset has enabled a whole range of new media to become available. This thesis investigates how these media have affected the way in which designers communicate, both internally within the design team, and externally to clients, suppliers and others. It has also looked at how it has affected the way others communicate externally to the designer, e.g. client to client peers, or client to potential marketplace.

The conclusions of the thesis essentially fall into three parts. The first part looks at the original research questions and objectives, and assesses how well they have been answered in terms of what the heuristic map tells us. The second part comprises of a reflection on the research process, before going on to discuss the contribution of such a process to the advancement of practice. Finally, the thesis will show how these elements of the study have made an original contribution to knowledge, with a clear statement as to that contribution. A postscript to this identifies the limitations of the map as well as the investigation as a whole and is followed by an identification of further work.

The aim of the research investigation was to:

- *Propose tactics for the integration of 3D digital media into the industrial design process.*

This had the associated objective:

- *Propose a model for the integration of 3D digital media into the potential development paths through the design process.*

The aim and objective were defined in order to answer the research questions:

- *How can industrial designers integrate 3D digital media into their design process?*
- *How can industrial designers use 3D digital media to communicate more effectively within their design process?*
- *When do industrial designers use 3D digital media to communicate within their design process?*
- *Why do industrial designers use 3D digital media to communicate within their design process?*
- *What does this tell us about the impact that 3D digital technologies are having on communication within the design process and therefore the execution of design projects?*

The completion of the case studies, their analysis and the subsequent synthesis to the heuristic map have sought to establish the answers to these questions, and are determined in the following section; *what does the map tell us?*

6.2 What does the map tell us?

It can be argued that the map satisfies the original research aim to, '*propose tactics for the integration of 3D digital media into the industrial design process*', in that the creation of the map itself represents the tactical approach to integrating 3D digital media with the industrial design process. It is through implementation of the map by designers that they will be able to determine the opportunities open to them in terms of using 3D digital technologies, seeing the advantages and disadvantages of their

use, as well as case examples. These tools give these designers the capability to determine their own tactics for application. Further, it can be seen that the creation of the map satisfies the associated objective to, *'propose a model for the integration of 3D digital media into the potential development paths through the design process'*.

'How can industrial designers integrate 3D digital media into their design process?': Successful integration of 3D digital media into the industrial design process requires an understanding of a broad range of factors, including the advantages and disadvantages of its use. The use of 3D digital media requires, by default, the initial creation of a 3D model. Once the commercial decision to employ 3D modelling has been made, the designer must understand all the issues raised by the propositions:

- *The integrity of the construction path may affect the future flexibility of the model.*
- *The mode or method of presentation may affect interpretation of form, finish, complexity and project progress.*
- *The decision to use computer modelling may affect the development of that design.*
- *Decision-making may be affected by the clarity of communication.*

How can industrial designers use 3D digital media to communicate more effectively within their design process?': The use of 3D modelling as a core element within the design process allows that 3D model to become a central design database, holding all the information regarding the configuration, component interaction and form definition of that design. The creation of a 3D model enables the design intent to be captured with complete accuracy, as early in the process as is deemed appropriate. However, the earlier in the process it is captured, the better the integrity of the model must be, as it will require modification as the design is developed. This central 3D database then allows the creation of a range of universal deliverables; these

deliverables are essentially the 3D digital media that can be created directly or indirectly from the 3D model. These media, identified in detail in the map, include: photo-realistic visualisation, 2D drawings and specifications, data for tooling, model making and rapid prototyping. These deliverables enable designers to communicate more effectively with a wide range of people, from a single data source. There is no recreation of data in order to communicate in a number of different ways to different recipients.

When do industrial designers use 3D digital media to communicate within their design process?: 3D digital media can be used throughout the industrial design process, although it is often more prevalent during the latter stages. The evidence presented by the map suggests that 3D modelling has a place within all stages. For example: it may be used very early to define the exact internal components of a products that the designer will then sketch around, that data may well then be the same data that is sent to the manufacturer at the specification stage.

Why do industrial designers use 3D digital media to communicate within their design process?: It is a powerful accurate medium through which to communicate the design intent. Often, the designer can clearly see in their mind's eye what they are seeking to achieve. For instance, sometimes the communication tools offered to us by sketches or sketch models do not provide the affordance necessary in order to adequately communicate our intentions. A sketch model made by hand from a drawing is dependent on the skill of the model maker in terms of its potential to communicate the design intent. It is also technically challenging to put accurate detail into such a model. However, if a sketch model is cut directly using CNC machining from a 3D data file, the model will remain completely accurate to the design intent, with the skill factor shifting to the designer's ability to build the model exactly as they want it in the virtual, rather than in the physical domain. These forms of media can then be used to communicate very powerfully both internally and externally. This 3D sketch model can be used initially by the designer to determine whether he/she and his/her colleagues are happy with the design. Following this, it

can be used as an accurate facsimile of the design to present to the client or perhaps to illustrate the form to other suppliers such as toolmakers.

What does this tell us about the impact that 3D digital technologies are having on communication within and therefore the execution of design projects?: The map tells us that 3D digital media can truly be integrated with the industrial design process and is much more than just an expensive add-on. Design projects are becoming more and more reliant on the use of 3D as it is the only sure way to maintain design intent throughout the process. It has increased our potential for communication enormously, but there are downsides. The introduction of 3D can suggest that the design is finished and complete, when in fact it may be far from this. The increased quality of communication can give a sense of security, and be very powerful. However, the use of 3D modelling has undoubtedly increased the burden of responsibility on the designer. Data being used directly for tooling may maintain the design intent, but it also means that the designer is responsible for getting that data right. Although the time taken to produce a model can be predicted, it is not as predictable as creating something by traditional means. There are many things that can go wrong, from software and hardware failures, through to errors due to a lack of designer skill. The use of 3D modelling can cause the designer to lose the 'big picture', so absorbed in creating the model and getting every detail right, there can be a loss of understanding regarding key issues, affecting the coherence of the design.

In summary, the main impact is that the designer is doing so much more; the designer is at the hub of the 3D design and communication space, acting as a vector for all the information concerning the core 3D database. Digital technologies and especially 3D digital modelling technologies represent the future for the industrial design profession, both for the act of and the communication of design. However it is only when they are used intelligently that they have power, and this power is relative to the role that a consultancy plays for an organisation or client. Some consultancies trade on the benefits to the client of a turnkey approach to product development, others, in a commanding position regarding creative design influence expect to arrive

at a design specification by a variety of means and often without the use of 3D CAD, hoping that their reputation will spur their client to accept their designs. Despite this, there is no doubt that these technologies have revolutionised the way we work, bearing out Rzevski's statement:

*"We are entering a new type of society, which means that designers will have to learn to communicate using digital technology, to design using digital technology, to obtain information, and market themselves using digital technology. There are a whole set of new skills to be learned, in order to be able to enjoy the opportunities that the information society offers."*¹

But, design doesn't depend on a formulaic or linear application of a set of digital modelling tools, the secret lies in a full and complete understanding of all the issues. In the exploration of techniques for the application of 3D technologies, it is believed that through the creation of the heuristic map, this research contributes to that understanding. Whether communicating to themselves or others, designers have always created images or models. They may be mental, physical or virtual, but all are tools to help them construct or communicate their concepts, using them to create, explore, understand and explain. What the designer faces today is a range of tools greater than ever before and they are beginning to find their feet. Designers are inherently flexible and experimental, and will make the digital tools fit the way they want to work, not the other way round.

6.3 Reflection on a practice based research programme

6.3.1 The methodological approach

Core to the methodological approach has been the experience of the researcher reflecting on practice in the commercial context. It is safe to say that there has been a considerable amount of post hoc. rationalisation of the methodology as an adapted action research method. However, much of the value of this research programme lies in its exploration of the use of action research methods in commercial industrial design practice. Although the researcher aspired to see ways in which reflective

practice could be drawn into the enquiry, commercial pressures meant that the reliance had to be on reflection on practice, rather than reflective practice within the true action research sense.

One of the features of taking this approach has been the personal involvement of the researcher as a design practitioner with the commercial design projects underpinning the core case study material. To allay any concerns as to the potentially subjective nature of this involvement, the methods for case study analysis were carefully considered in order to maintain as objective a stance as possible. Although the study cannot show a true practice diary, a pre-requisite of a true action research methodology, the reconstruction of the process was possible using personal and peer knowledge, and all data collected as part of being a participant in the process. In addition, the use of peer review helps to establish a level of contemporary relevance to the findings. The path of evolution of the research design and its relationship to Action Research in the context of hectic commercial case studies meant that the production of a practice diary to demonstrate the reflective practice element of the case studies was not possible.

On reflection, there are some compelling arguments as to why such a personal involvement has been of positive benefit to the research programme, and, why the use of reflection on practice has enabled the derivation of the findings presented in the thesis. There is no doubt that the result of the research would not have been the same if the researcher had not been personally & intimately involved in the case study process. The study would not have progressed the cause of integrated commercial design research, if a less involved approach had been adopted, or have enabled the same understanding or yielded the same set of findings. The arguments for personal involvement in the research subject can be made from a number of standpoints.

Design is an intimate and involved activity, where discussions on the design process frequently refer to the designer's intuition, i.e. that part of the design process that is

most difficult to measure or quantify. Although external controls are applied to the design process in the form of client reviews and so on, the process of designing is extremely fragmented, involving many activities all happening at once. Designers are constantly pulling the fragments together to see if they fit and make a coherent whole². It is only when a designer makes sense of these fragments and fits them together that the idea is externalised and made explicit. It is argued that if the researcher is observing only the explicit activities of the designer, then only one half of the picture is made explicit and therefore able to be observed. Being involved in the process enabled the researcher to see the process in its fragmented as well as complete form.

The definition of a methodological framework, which allowed the unhindered execution of commercial design projects, whilst enabling them to be the case studies in a research study was a key factor of the programme. Gray argues for a more integrated approach to practice-led research, research that is driven by and useful to practice:

“Research should not be seen as being in conflict with practitioners’ methods but an expansion of them. Perhaps separation is futile, as what we are trying to do is integrate and synthesise the best aspects of each into a critical dialogue, which needs two elements to create it: practice-led research is simultaneously generative and reflective.”³

Contrary to social scientists such as Yin⁴, this research argues for an approach that is participatory, it is argued that it is through active participation that we can truly see all aspects of the process and therefore make a more pertinent contribution to knowledge for practice.

Whilst the research process and associated methodologies do not fit within a well established tradition, there has been a concerted effort on the part of the researcher to determine as much methodological rigour as possible, whilst carrying out research within the context of commercial practice.

If the study were to be attempted again, in hindsight it would not be carried out in quite the same manner. A number of activities would be undertaken to ensure refinement of methodological technique and possibly create a greater rigour in the research process:

- Now that the utilisation of reflective practice methods for practice based art and design research projects has been debated and developed more throughout academia, it would be possible to more easily define the methodology for such a research project as this in advance, rather than evolving its application throughout the study including a process of post hoc. rationalisation.
- Stronger selection criteria would be applied to the choosing of case study projects. If projects conformed they would be studied until for some reason they no longer conformed, this lack of conformity would then be incorporated into the research findings.
- A more concurrent method for recording the reflective cycle within case study events would be attempted, possibly through the implementation of more effective project records.

6.3.2 The Value of Practice Based Research

The ultimate objective of research is to develop theories that will inform practice. Whilst the importance of purely academic design research is acknowledged, in the researcher's experience, the majority of research findings never even reach the practicing designer. Illustrated by recent and vocal debates amongst the design community⁵, despite movements towards a greater acceptance of practice-based research, there remains a significant tension between professional practice and academic research⁶. Practicing designers have little time to read research papers and in many cases cannot see the relevance of such research to their practice. Unlike professions such as law or medicine, designers are often dismissive of the potential importance of research to their profession and are often unaware of the rigours required to produce valid and useful research. Academics who do not undertake

commercial design practice or who have never done so will find it difficult to appreciate the commercial pressures faced by the practitioner. Research that might have great significance to the practicing designer may never escape the academic realm. This may be due to the form of presentation or a perhaps a lack of opportunities for more widespread dissemination.

This thesis argues the case for research that informs practice, it is believed that this is absolutely necessary to the development of the design profession. Practitioners and academics alike have a responsibility to understand and develop the role of research, and this thesis presents one view of a way in which this might be done.

6.3.3 Validity of the timeframe

This thesis has taken a long time to complete, approximately eight years. At the start the focus of the study on technology was seen to be a significant problem. The belief was that by the time the research was complete it would be out of date, and this was based on the assumption of the timeframe of a full time study. However, it can be seen from the researchers own experience, that many of the core questions remain valid, despite changes in technology.

On reflection, the long timeframe of the programme has actually been beneficial, as it has been able to establish a greater validity to the findings. Had the research been completed over a much shorter time frame, it may have been possible to dismiss the results as transient or completely software dependent. Digital technologies are not 'fly-by-night' fancies that designers will pick up today and drop tomorrow. The introduction of 3D computing has fundamentally changed the way in which designers work and a decade after their introduction, designers are still coming to terms with their integration with practice.

6.3.4 Trends in design research

Design research is still an infant compared to established disciplines within the research fields of science and the humanities, where methodological approaches and

the relationship between research & practice are firmly established and well understood. There is no doubt that design research activity has exploded in the past ten years but the focus of attention on methodology and the recurring subject of the relationship between research and practice in current design community debates⁷ illustrate that rather than having all the answers, more and more questions keep opening up.

There are some significant issues associated with being a practitioner-researcher, which may have an implication on the execution of a research programme. The following points are based on the personal experience of the researcher as a researcher/practitioner both within academia and consultancy practice and are specifically relevant to the execution of PhD research.

Commercial Constraints

The pace of commercial activity is such that in the majority of instances it will be difficult to find time to 'research' design projects as they are being carried out. Methodologies need to be developed which take account of this and create a research 'framework' which is sympathetic with project execution. Under standard employment conditions, time to attend conferences or carry out research activities that are not part of the commercial activities of the employing company is difficult to find, even sympathetic employers may find it difficult to justify non fee-paying activities. Most designers are committed individuals who work hours far in excess of contract; deadlines require a commitment to long hours with little 'free' time for writing research papers or theses. Out of the academic environment access to libraries and the basic tools of research can be problematic. Also, information regarding relevant events such as conferences and seminars will not be so apparent.

Attitude & Education

Design employers can have very varying attitudes to research. Carrying out research within a company with a negative attitude to research could present significant problems. Designers might have difficulty seeing the value of research or

understanding the rigours and demands of a research programme. It is the researcher's profound belief that within current methodological constructs, researching design and designing require quite different priorities, making it difficult for the researcher to make the switch from one mode of thinking to another, a problem exacerbated for designers with no experience of research. It is suggested that designers, at the very least, require training in keeping with students of other disciplines in research practices and techniques. Friedman argues that adequate research training is an essential driver for eventual success in design practice⁸.

Confidentiality

Designers are responsible to their clients for confidentiality. Many designers will be unwilling to talk about their processes to a designer from a company who they might be in competition with. They also may not be able to talk about specific projects until some considerable period following the projects completion.

The issues of appropriate methodologies, commercial constraints, attitudes, education and confidentiality are all absolutely core to the design research / design practice debate.

6.3.5 Contribution of the research process to the advancement of practice

The research programme has provided a valuable contribution to the advancement of practice in the following areas:

- In defining an approach for practice-led research, a method for the elicitation and analysis of case study data. Showing that it is possible to carry out research within practice, using commercial projects as case studies.
- In the definition of issues and problems related to practice-led research.
- In the presentation of research results in the form of an interactive map. The map represents a technique that designers can employ to find out more about the integration of 3D digital media, prior, during, or following implementation of 3D digital technologies.

- In the definition of a set of core findings relating to the characteristics and use of different media types within the context of commercially driven projects.
- In the acknowledgement that this research does not provide the answers to all the questions regarding the integration of 3D digital technologies or in methods for practice-led research or in the presentation of research findings to design practitioners. But that it does provide a platform upon which other designer/researchers might stand and see a better way forward for the execution and dissemination of research by and for practice.
- The dissemination of results via the Internet, ensure that the results are accessible by both the research and practice communities, as well as to academia for students of design.

6.4 Contribution to Knowledge

It can be seen from section 6.2, that the research questions have been answered and conclusions regarding the integration of 3D digital media into the industrial design process drawn. The contribution to knowledge is apparent in two distinct areas:

- A heuristic map for digitally integrated design represents the first contribution to knowledge. It provides an in depth summary of all the usage issues relative to four different aspects of design action: analysis, conceptual design, proposals and, detailing and specification, as well as three different types of communication: internal, external and extra external. Although only a first draft, the map is presented in such a way that makes it accessible to all readers, whether they are students, designers, researcher or educators.
- The second contribution to knowledge is apparent in the way that the research programme was carried out. Design research using practice as a resource is not uncommon, however, design research within the context of live commercial practice is. This programme has adapted a number of methodologies to define a method that enables the design process to be recorded free from the concern of

the research agenda interfering with the natural progress of the commercial design project.

The research programme has followed the enquiring process of practice-led empirical research into art and design⁹. The use of commercial case studies within research programmes is inherently problematic but it can provide insights into the little revealed world of commercial design practice. The main objective of this programme has been to utilise the real everyday practice of design and draw out the tacit knowledge and understanding that designers have in order to help other designers in the field. The map is intended as a reflection of this everyday activity, providing some guidance on the tactical application of digital technologies to the industrial design process.

6.5 Restrictions and limitations

6.5.1 Current trends in the use of 3D digital technologies

One of the most important developments since the investigative stage of this study was completed has been in the development of 3D modelling software. The software used in the case studies described in this thesis were Alias and Pro/Engineer, at the time these reflected the state of the art in what have been described here as 'constrained' and 'unconstrained' digital modellers.

Although Alias & Pro/Engineer are still widely available and widely used, they have developed significantly and there are now many more modellers available. These include software packages such as Unigraphicsⁱ, which enable the designer to mix the use of surfaces and solids as they are modelling, allowing a mixture of constrained or unconstrained modelling within the same software package. In these new packages the distinction between constrained and unconstrained becomes blurred as the designer's modelling objectives can be achieved within the context of

ⁱ Unigraphics: see Glossary

a single modelling environment. A significant quality of 3D modelling capability is now being offered within much cheaper software programmes such as Rhino3Dⁱⁱ. Add to this the fact that these software packages can run on much cheaper hardware platforms than ever before, and the access to 3D is now much more affordable than it was when the investigative phase of this study was underway.

The focus of the research investigation has always been on the ultimate use of the media generated as a consequence of creating a 3D model, rather than on the specific act of modelling. Therefore, although the processes to create this 3D model within new and developed software packages might be different, the general considerations for using its outputs may well be the same. The implications of this to the research are that the 3D digital model categories of ‘constrained’ and ‘unconstrained’ modelling are no longer contemporaneously accurate and were the map to be extended to include contemporary case studies, would have to be modified.

With the price of established technologies ever decreasing, CNC machines are becoming more commonplace and enable a kind of 3D ‘printing’, where the designer can evaluate their 3D virtual model by creating a physical facsimile. Further to this, there are many developments mainly through the increased use of digital presentation packages and the Internet for the purposes of communication; these comprise an area of study in their own right.

Other important developments within the researcher’s practice include the use of VRMLⁱⁱⁱ where 2D hand drawn or computer-generated renderings are texture mapped onto a 3D model, which can then be interacted with. Other developments include the combined use of 2D and 3D digital rendering techniques in order to create multiple colour options from a single 3D model, much more quickly than by rendering the 3D model to the desired colour within the 3D package itself. Other

ⁱⁱ Rhino3D: see Glossary

ⁱⁱⁱ VRML: see Glossary

commonly used techniques, especially in the automotive sector, involve the use of digital sketching tools, where 3D form is simulated, using sketches as a basis¹⁰. This is similar in intent to the VRML technique and means that the 3D model can be presented to the client much earlier in the development cycle, with much less investment in time, showing proposals for detail without actually having to create it^{iv}. Technologies such as VRML and Web 3D^v also allow the creation of interactive 3D simulations and the viewing of digital models concurrently across a number of remote sites. In addition, the 3D data models created within the researcher's practice are routinely used directly for engineering development and tooling, this is still not common practice within most design consultancies.

In general terms the use of digital technologies, whether it be multimedia presentations or the creation of 3D digital models, are becoming more and more prevalent throughout practice. It is now the norm that presentations to clients are made via the use of a digital projector, virtual models become physical, and that data are shipped around the world over the Internet¹¹. Such technologies add significantly to the designer's toolset, tools that enable designers to develop designs in a more effective and efficient way, with better communication enabling more effective decision making.

6.5.2 Limitations of the Heuristic Map

This thesis argues that the Heuristic Map for Digitally Integrated Design establishes a framework for helping designers understand how 3D digital technologies might be applied to the industrial design process. However, it is by no means finished and there are significant limitations to the map in its current form:

- The map has been created on the basis of work carried out within the Centre for Industrial Design between 1992 & 1996; the data collected are only specifically

^{iv} Such techniques are currently being employed by XPD (a design consultancy, part of the Xpress Engineering Group, based in Tyne & Wear) in conjunction with VirDev in the USA.

^v Web 3D: see Glossary

relevant to that period. Although it is argued that the findings still have significant contemporary relevance it is acknowledged that the addition of contemporary case studies to the data set would give the map greater credibility.

- The illustrations used in the map are taken only from the three main research case studies. Ideally, future incarnations of the map would include examples from different design consultancies and from all areas of design.
- Due to the timeframe of the period of investigation, the map does not cover all media forms that are now currently available, further research would be required to determine what these are and their associated characteristics.
- The map as it is presented here is essentially a first draft, which has been exposed to only limited peer review. A full evaluation would have to be undertaken to ensure that the map represented a broader view before the map could be presented as a usable and workable tool to the wider industrial design profession as a whole to use for teaching, practice, research or management activities.

6.5.3 Limitations of the Thesis

The thesis is restricted to the study of industrial design practice only. The uses of 3D computing and digital technology for other disciplines are not within its remit.

There is a school of thought, which defines a fourth dimension: *4D*¹², as referring to the dynamic, interactive & hypermedia forms of design. The 4D concept could be exemplified by, “*intelligent buildings, smart products and multimedia systems*”¹³. The concept of a fourth dimension can be seen as a further extension of the cross-disciplinary nature of the design profession¹⁴ and many of its embodiments are linked to the initial creation of a 3D data model. The relevance of the concept is acknowledged, but not studied within the confines of this thesis.

The case studies reflect only independent consultancy practice and do not extend to industrial design within the corporate environment. The cases cover three design

projects, all of which are within the medical field. Although the principal investigation is based on these three exemplar projects, they cover a broad base of design requirements and the study has drawn in general from many more projects. The thesis suggests that the results can be generalised to a broader range of industrial design practice, however it is accepted that there would undoubtedly be additional findings arising as a result of in depth study into different areas of industrial design.

The continuation of this study following the researcher's departure from the Centre for Industrial Design has had a major influence on the outcomes of the research. Following initial difficulties, it became apparent that the experience made a significant contribution to the value of the study. The study has therefore spanned professional practice in three different consultancies, the knowledge gained in each one adding to the knowledge and experience of the researcher. It is believed that this contributes to the validity of the findings.

6.6 Further Work

Recommended further work would centre mainly on the development of the heuristic map. The map as it stands is only a first draft of potentially how such a map might appear if it were to be developed for dissemination to the industrial design profession. In order to present the map as a truly useful tool for practice it would have to undergo significant amounts of further input and evaluation, the following development tasks are recommended:

1. The data presented by the current map should be compared with data from a range of contemporary case studies executed within a range of design environments. Data would need to be examined from a range of industrial design product types, i.e. consumer electronics, furniture, capital goods, nursery products, street furniture, sports goods, medical products etc. Incorporating a range of design environments, i.e. consultancy or corporate, across a range of technological competencies.

2. Agreement on terminologies and media descriptors between different design groups, i.e. making sure that terminology is commonly acceptable and jargon free.
 3. Evaluation by the research and design community as a whole, evaluation not only in terms of content (which would be done via comparison of the data with contemporary cases) but in terms of format and presentation media. A methodology for the evaluation procedure and data collection and integration would have to be devised.
-

¹ RZEVSKI, G. Views from a helicopter, in *Co-Design Journal*, 07.08.09, 1995, p. 6-11.

² CROSS, N. Styles of learning, designing and computing, in *Design Studies*, Vol. 6, No. 3, July 1985, p. 157-162.

³ GRAY, C. Inquiry through Practice: Developing Appropriate Research Strategies in Art & Design. *No Guru No Method*, International Conference on Art and Design Research, Helsinki, Finland, 4-6 September 1996. Proceedings, p. 82-95.

⁴ YIN, R, K. *Case Study Research – Design and Methods*, Sage, 1994, 2nd Ed.

⁵ DRS Email Discussion List. 2000

⁶ GRAY, C. Op. cit.

⁷ Conferences held in 2000 include the following: *Doctoral education in design: foundations for the future*, La Clusaz, France. 8-12 July 2000. *Research into Practice*, University of Hertfordshire, England, 7 July 2000.

⁸ FRIEDMAN, K. Posting on the DRS Discussion List (Notes on Rob's and Klaus's clarification to Ken's points), 31 May 2000, unpagged.

⁹ SEAGO, A. *Research methods for MPhil & PhD students in art and design: contrasts and conflicts*, RCA Research Papers, Vol. 1, No. 3, 1994/5.

¹⁰ SIODMOK, P & COOPER, A. *Advanced 3D CAD methodologies used in contemporary industrial design practice* at 'Hong Kong Productivity Council Conference', Hong Kong, March 2000.

¹¹ DESBARATS, G. *Data Exchange in 2000*. Paper presented at Solid Modelling 2000 Conference, March 8-9 2000, NEC, England.

¹² 4D dynamics: an international interdisciplinary conference on design and research methodologies for dynamic form. De Montfort University, England, September 21, 1995. *4D Dynamics*. Proceedings, A. Robertson (Ed). 1995.

¹³ ARCHER, B. *Keynote Address*, at 4D dynamics: an international interdisciplinary conference on design and research methodologies for dynamic form, De Montfort University, England, September 21, 1995. *4D Dynamics*. Proceedings, A. Robertson (Ed). 1995.

¹⁴ ARCHER, B. *Ibid*.

BIBLIOGRAPHY

- 4D dynamics: an international interdisciplinary conference on design and research methodologies for dynamic form. De Montfort University, England, September 21, 1995. *4D Dynamics*. Proceedings, A. Robertson (Ed). 1995.
- AKIN, O. An exploration of the design process, in *Design Methods & Theories*, 13 (3/4), 1979, p. 115-119.
- ALEXANDER, C. and POYNER, B. cited in Cross, N (Ed.) *Developments in Design Methodology*, Wiley, 1984, p. 100.
- ALEXANDER, C. *Notes on the synthesis of form*. Harvard University Press, 1964.
- ALEXANDER, C. *The determination of components for an Indian village* in Cross, N. (ed.) *Developments in Design Methodology*, Wiley, Chichester, 1984.
- ARCHER, B. A background to doctoral awards. International conference on doctoral education in design, La Clusaz, France, 8-12 July 2000. *Doctoral Education in Design: Foundations for the Future*. Proceedings, edited by D. Durling and K. Friedman. Staffordshire University Press, 2000, p. 257-260.
- ARCHER, B. *Design as an interdisciplinary domain*. Paper presented at DRS Council Meeting, University of Derby, 20th September 1996.
- ARCHER, B. *Keynote Address*, at 4D dynamics: an international interdisciplinary conference on design and research methodologies for dynamic form, De Montfort University, England, September 21, 1995. *4D Dynamics*. Proceedings, A. Robertson (Ed). 1995.
- ARCHER, B. *Systematic method for designers*. The Design Council, London, 1965.
- ARCHER, B. The Nature of Research, in *Co-Design Journal*, 01.02.03, 1995, p. 6-13.
- ARCHER, B. Whatever became of design methodology?, in *Design Studies*, 1 (1), 1979, p. 17-18.
- ARGYRIS, C. *Increasing leadership effectiveness*, Wiley, New York, 1976.
- BAKER, R. *Designing the Future*, Thames & Hudson, 1993.
- BRITISH STANDARD BS 7000. *Guide to managing product design*, BSI, London, 1989, p. 3.
- BROADBENT, G. The development of design methods, in *Design methods and theories*, 13 (1), 1979, p. 41-45.

- BRUCE, M. The design process and the 'crisis' in the UK information technology industry, in *Design Studies*, Vol. 6, No. 1, 1985, p. 34-40.
- BUNNEL, K. *Re: Presenting Making*, the integration of new technology into ceramic designer-maker practice, Ph. D. Thesis, Gray's School of Art, The Robert Gordon University, Aberdeen, 1998.
- CAD, Colour & Communication – Conference, University of Derby. September 20, 1996.
- CADE 97: 'Digital Creativity' – Conference, University of Derby. April 1997.
- CARDACI, K. cited in MCCULLAGH, K. 3D modelling in industrial design, in *Co-Design Journal*, 07.08.09, 1996.
- CLIPSON, C. Redesigning design: some critical dimensions for research, in *Co-Design Journal*. 01.02.03, 1995, p. 22-28.
- Computer Aided Industrial Design – Reflections & Insights – Conference, UNN, 1993.
- CONCISE OXFORD DICTIONARY 8th Ed. Fowler, H W & Fowler, FG (Eds)., Oxford University Press, 1990.
- CROSS, N. *Developments in Design Methodology*, Wiley, Chichester, 1984.
- CROSS, N. *Engineering Design Methods: strategies for product design*, 2nd Ed.. Wiley, Chichester, 1994.
- CROSS, N. Styles of learning, designing and computing, in *Design Studies*, Vol. 6, No. 3, July 1985, p. 157-162.
- DALEY, J. Design creativity and the understanding of objects, in *Design Studies*, 3 (3), 1982, p. 133-137.
- DARKE, J. The primary generator and the design process, in *Design Studies*, 1 (1), 1979, p. 36-44.
- DESBARATS, G. *Data Exchange in 2000*. Paper presented at Solid Modelling 2000 Conference, March 8-9 2000, NEC, England.
- Design of the Times – Conference, Staffordshire University. October 5, 1994.
- DORMER, P. *Design since 1945*, Thames & Hudson, 1993.
- DRURY, J. Computer Aided Design at Black & Decker, at *Product Design and 3D Computer Modelling* Conference, Sheffield City Polytechnic, April 7 1992.
- DURLING, D. Intuition in Design, in *Bulletin of 4th Asian Design Conference*. International Symposium on Design Science, Nagaoka, Japan, October 1999. ISBN 4-9980776-0-0 C3072.

DURLING, D. *On Category mistakes*. Design Research Society email discussion list. 26th April 2000.

DURLING, D. Review of CD of Ph.D. thesis by BUNNEL, K, Presenting Making, posted on DRS discussion list, 12 May 2000.

DURLING, D., CROSS, N. & JOHNSON, J. CAI with Style. In: *Proceedings of SEED 96* (Conference on sharing experience in engineering design), 26-27 June, University of Bristol.

FERGUSON, E. *Engineering and the minds eye*. MIT Press, Cambridge, 1994, p. 23.

FRAYLING, C. *Research in Art and Design*, RCA Research Papers, Vol. 1, No. 1, 1993/94.

FRENCH, M. J. *Conceptual design for engineers*, Design Council, London, 1985.

FRIEDMAN, K. Posting on the DRS Discussion List (Notes on Rob's and Klaus's clarification to Ken's points), 31 May 2000, unpagged.

GRAY, C. Inquiry through Practice: Developing Appropriate Research Strategies in Art & Design. *No Guru No Method*, International Conference on Art and Design Research, Helsinki, Finland, 4-6 September 1996. Proceedings, p. 82-95.

HALSEY, A. H. *Educational priority*, V1, HMSO, 1972.

HERTZ, K. A coherent description of the process of design, in *Design Studies*, Vol. 13, No 4, 1992. p. 393-410.

HICKLING, A. Beyond a linear iterative process?, in '*Changing Design*', (Eds.) B. Evans, J. A. Powell, R. J Talbot, Wiley, 1992.

HILLIER, W., MUSGROVE, J. and SULLIVAN, P. 'Knowledge and design', in Mitchell, W. J. (ed.) *Environmental Design: Research and Practice*, University of California, 1972.

HOLLINS, B. The management of concurrent engineering and total design, in *Co-Design Journal*, 04.05.06, 1995, p. 22-27.

HOLNESS, A. Current PhD programme at UNN, entitled *The analysis of design methods by a comparative study of award-winning industrial architecture since 1970*.

HUGHES, C. & CUNNINGHAM, L. Design creativity – with a mouse? In *Co-Design Journal*, 07.08.09, 1996, p. 86-88.

HUIISH, P. Simultaneous engineering with respect to direct CAD-based Simulation Analyses Models, at *Virtual Representations for Design and Manufacture Symposium*, Coventry University, December 16, 1992, p. B3.

HUNDAL, M. S. Recent computer related design in the USA, in *Design Studies*, Vol. 12, No. 4, October 1991.

Information Technology & Design: New Perspectives – Conference, University of Central England. February 16, 1993.

JOHNSON, A. L. & THORNTON, A. C. Towards real CAD, in *Design Studies*, Vol. 12. No. 4. October 1991.

JONES, J. C. A method of systematic design in Cross, N. (ed.) *Developments in Design Methodology*, Wiley, 1984.

JONES, T & FEARIS, P. Computer integrated design within product design consultancy, in *Co-Design Journal*, 07.08.09, 1996, p. 80-85.

KUHN, T. *The structure of scientific revolutions*. University of Chicago Press, 1962.

LAING, L. W. W. Book Review of, Kennedy, L. E: 'CAD: drawing, design and data management', The Architectural Press, London, 1986, in *Design Studies*, Vol. 9, No. 1, January 1988.

LANGRISH, J. Case studies as a biological research process, in *Design Studies*, Vol. 14, No. 4, 1993, p. 357-364.

LAWSON, B. Cognitive strategies in architectural design, in *Ergonomics*, 22 (1), 1979, p. 59-68.

LAWSON, B. *How Designers Think*, Butterworth Architecture, 2nd Ed. June 1991.

LEVIN, P. H. Decision making in urban design, in *Building Research Station Note*, EN 51/66, 1966.

LEWIN, K. cited in McNiff, J. *Action Research – Principles & Practice*. MacMillan, London, 1988.

LEWIN, KEMMIS, ELLIOT & EBBUTT, cited in McNiff, J. *Action Research – Principles & Practice*. MacMillan, London, 1988.

LLOYD, M. The culture of connectedness, in *Co-Design Journal*, 07.08.09, 1995, p. 12-14.

LUCKMAN, J. An approach to the management of design, in *Operational Research Quarterly*, 18 (4), 1967, p. 345-358.

MAIER, C. All together now, in *Design*, April 1994, p. 30-33.

MARCH, L. J. *The logic of design*. In: N Cross (ed) *Developments in design methodology*, Wiley, Chichester, 1984

MARRIS, P., and REIN, M. *Dilemmas of social reform: poverty and community action in the United States*, Routledge, 2nd Ed., 1972.

MAVER, T. W. Social impacts of computer-aided architectural design, in *Design Studies*, Vol. 7, No. 4, October 1996, p. 178.

MAVER, T. W. The future of CAAD: *Can we get there from here?* Keynote address at ACADIA 96, Tucson, USA, 1996.

McCULLAGH, K. 3D computer modelling in industrial design. in *Co-Design Journal*, 07.08.09, 1996, p. 28-35.

McCULLAGH, K. *Investigating the factors which influence the strategy of integrating three dimensional computer aided design techniques within industrial design consultancy practice*. PhD Transfer Document. UNN, September 1993.

MCKERNAN, J. *Curriculum Action Research*. Kogan Page, London, 2nd Ed., 1996.

McNIFF, J. *Action Research – Principles & Practice*. MacMillan, London, 1988.

MILES, M. B. and HUBERMAN, A. M. *Analyzing qualitative data: a source book for new methods*, Sage, Beverly Hills, CA, 1984, p. 103.

MORTIMER, J. and HARTLEY, J. *Simultaneous Engineering: An executive guide*. DTI, London, 1991.

MURANKA, T. & ROOTES, N. *Doing a Dyson*, Dyson Appliances Ltd. Malmesbury, 1996. ISBN: 0 9528935 0 9.

MYERS, B. A. A Brief History of Human Computer Interaction Technology, in *ACM Interactions*. Vol. 5, no. 2, March 1998, p. 44-54.

NACHMAIS, D., and NACHMAIS, C. *Research methods in the social sciences*. New York: St Martin. 1992.

OSTERMAN, K. and KOTTKAMP, R. *Reflective practice for educators: improving schooling through professional development*. Corwin Press, 1993.

PAHL, G. AND BEITZ, W. *Engineering Design*, Design Council, London, 1984.

PEDGLEY, O. F. *Industrial designers' attention to materials and manufacturing processes: analyses at macroscopic and microscopic levels*, PhD thesis. Loughborough University, Loughborough, 1999.

PLATT, J. 'Case Study' in American methodological thought, in *Current Sociology*, 40, p. 17-48, 1992.

POPPER, K. *Conjectures and Refutations: The Growth of Scientific Knowledge*. Harper & Row, New York, 1965.

POPPER, KUHN and LAKATOS. cited in Cross, N (ed.) *Developments in Design Methodology*, Wiley, Chichester, 1984. p. 238.

Product Design and 3D Computer Modelling - Conference, Sheffield City Polytechnic, April 7, 1992.

PRYCE-JONES, D. Conceptual Design using 3D computer modelling, at *Product Design and 3D Computer Modelling Conference*. Sheffield City Polytechnic, April 7, 1992.

PRYCE-JONES, D. Interfacing Industrial Designers with CAD, at *Information Technology & Design: New Perspectives Conference*, University of Central England, February 16, 1993.

PURCELL, P. Computer environments for design and designers, in *Design Studies*, Vol. 9, No. 3, 1988, p. 144-49.

PURCELL, P. *The Electronic Design Studio*, MIT Press, Editors Purcell, P (w/ MITCHELL, WM. & MCCULLOGH, M.), Cambridge Mass. & London, 1990.

RAMSDEN, P. *Learning to teach in higher education*. Routledge 1992.

REICH, Y. Annotated bibliography on research methodologies, in *Artificial Intelligence for Engineering Design, Analysis & Manufacturing*, 8, 1994, p. 355-366.

REICH, Y. Layered models of research methodologies, in *Artificial Intelligence for Engineering Design, Analysis & Manufacturing*, 8, 1994, p. 263-274. [Adapted from Smith, C. N. and Dainty, P. (eds.) *The management research handbook*, Routledge, London, 1991. and Reason, P. and Rowan, J. (eds.) *Human enquiry: a sourcebook of new paradigm research*, Wiley, New York, 1981.]

RITTEL, H. and WEBBER, M. *Planning problems are wicked problems*, in Cross, N. (ed.) *Developments in Design Methodology*, Wiley, Chichester, 1984.

RITTEL, H. Second generation design methods, in *The DMG 5th Anniversary Report: Occasional Paper*, No. 1, 1972, p. 5-10.

RUST, C. et al. *The management of information technology in the professional practice of three dimensional design*. Sheffield Hallam University, ISBN 0863393748, 1993.

RUST, C. Out of the hothouse?, in *Co-Design Journal*, 07.08.09, 1996, p. 16-21.

RZEVSKI, G. Views from a helicopter, in *Co-Design Journal*, 07.08.09, 1995, p. 6-11.

SCHON, D. *Educating the Reflective Practitioner*, Jossey Bass, 1991.

SCHRAMM, W. *Notes on case studies of instructional media projects*, working paper, the Academy for Educational Development, Washington DC, 1971.

SCRIVENER, S. Towards the operationalisation of design research as reflection in and on action and practice. International conference on doctoral education in design, La Clusaz, France, 8-12 July 2000. *Doctoral Education in Design: Foundations for the Future*. Proceedings, edited by D. Durling and K. Friedman. Staffordshire University Press, 2000, p. 387-394.

- SCRIVENER, S. A. R & CLARKE, S. M. *Sketching in collaborative design in Interacting with Virtual Environments*, Wiley, 1994.
- SEAGO, A. *Research methods for MPhil & PhD students in art and design: contrasts and conflicts*, RCA Research Papers, Vol. 1, No. 3, 1994/5.
- SHICKLE, M. A new way to think about product development at *Networking Design*, Design for Industry Course Conference, UNN, March 21, 1996.
- SIEBER, S. D. The integration of fieldwork and survey methods, in *American Journal of Sociology*, 78, 1973, p. 1335-1359.
- SIMON, H. The structure of ill structured problems, in *Artificial Intelligence*, 4, 1973, p. 181-200.
- SIODMOK, P & COOPER, A. *Advanced 3D CAD methodologies used in contemporary industrial design practice* at 'Hong Kong Productivity Council Conference', Hong Kong, March 2000.
- STAKE, R, E. *The Art of Case Study Research*, Sage, 1995.
- STAUFFER, L. A., and ULLMAN, D. G. A comparison of the results of empirical studies into the mechanical design process, in *Design Studies*, Vol. 9, No. 2, 1988, p. 107-114.
- SUNTHARALINGHAM, P. Alias and the Design Process, at *Information Technology & Design: New Perspectives* Conference, University of Central England, February 16, 1993.
- TEMPLE, S. Thought made visible - the value of sketching, in *Co-Design Journal*, 10.11.12, 1994, p. 16-25.
- THOMAS, J. and CARROLL, J. The psychological study of design, in *Design Studies*, 1 (1), 1979, p. 5-11.
- TOVEY, M. & DEKKER, K. CAD & Virtual Representation for Industrial Design, at *Virtual Representations for Design and Manufacture* Symposium, Coventry University, December 16, 1992.
- TOVEY, M. Drawing and CAD in industrial design, in *Design Studies*, Vol. 10, No. 1, 1989. p. 24-39.
- TOVEY, M. Form Creation Techniques for Automotive CAD, in *Design Studies*, Vol. 15. No. 1, 1994. p. 85-114.
- TOVEY, M. Intuitive & Objective Processes in automotive design. in *Design Studies*, Vol. 13 No.1, 1992. p. 23-41.
- TROCHIM, W. Outcome pattern matching and program theory, in *Evaluation and Program Planning*, 12, 1989, p. 355-366.

VAN DIJK, C. G. C. New insights in computer aided conceptual design, in *Design Studies*, Vol. 16, No 1, 1995. p. 62-80.

Virtual Representations for Design and Manufacture - Symposium, Coventry University. December 16, 1992.

WALKER, D et al. Editorial Notes, in *Co-Design Journal*. 07.08.09, 1995, p. i-iv.

WALKER, R. *Three good reasons for not doing case study research*. Paper presented at the annual meeting of the British Education Research Association at Crewe and Alsager College of Education, Cheshire, September 1981., & MILES, M. Qualitative data as an attractive nuisance: The problem of analysis, in *Administrative Science Quarterly*, 24, 590-601, cited in: STAKE, R. *The Art of Case Study Research*, Sage, 1995, p. 45.

WARBURTON, N. *Digital Integration & Designer Tactics*. CADE Postgraduate Conference, Coventry University, March 26, 1996. WARBURTON, N. A Heuristic Model for Digitally Integrated Design, in *Co-Design Journal*, 07.08.09, 1996, p. 22-27.

WHITEHEAD, J. Creating a living educational theory from questions of the kind, 'how do I improve my practice?', in *Cambridge Journal of Education*, Vol. 19, No.1, 1989.

YIN, R, K. *Case Study Research – Design and Methods*, Sage, 2nd Ed., 1994.

YIN, R. K. *Applications of case study research*. Sage, Beverly Hills, CA, 1993.

YIN, R. K., BATEMAN, E., and MOORE, G. B. *Case studies and organizational innovation: Strengthening the connection*, Washington DC, COSMOS Corporation, 1983.

YOUNG, R. A. *Developments in the theory and practice of reflective design practice*, in *Useful and Critical*, International Conference on Art and Design, Helsinki, Finland, 1999.

GLOSSARY

3D Go: 3D modelling and animation package.

Adobe Illustrator™. Electronic illustration software.

Adobe Photoshop™. Photo & image manipulation software.

Adobe Premier™. Moving image compilation and editing software.

Alias: Now known as Alias/Wavefront. A surface modelling and photo realistic rendering package.

CAD: Computer Aided Design. The act of design, directly assisted by the use of a computer.

CAD/CAM: Computer Aided Design and Manufacture, using computers to facilitate direct links between design and tooling and manufacturing facilities.

CAID: Computer Aided Industrial Design. As above, but specific to the practice of Industrial Design.

CDRS: 3D solid modelling package, developed by Evans & Sutherland.

CNC: Computer Numerically Controlled.

Discussion Lists: email based forums for the exchange of views and ideas.

Euclid: Solid modeller developed by Matra Datavision.

HTML: Hypertext Mark-up Language – a source code which defines the layout of text and graphics on web pages.

I-DEAS: 3D solid modelling package developed by SDRC (Structural Dynamics Research Corporation).

I-Design: 3D solid modelling package developed by Intergraph.

Macromedia Director™. Multimedia authoring software.

Multi-Axis Machining: The machining of a model or tool directly from computer data, using machining heads which can cut in a number of axis.

NT: Microsoft workstation operating system.

Pro/Engineer: Leading solid modeller developed by Parametric Technologies.

Rapid Prototyping: The creation of 3D models & prototypes, using data generated from a 3D computer model.

Rhino3D: A 3D modelling tool (solids & surfaces) based on Non-Uniform Rational B-Splines (NURBS).

Site: This refers to an html document which can be viewed either remotely via the world wide web (WWW) or directly using a WWW browser.

SLA: Stereo Lithographic Apparatus. A rapid prototyping technique whereby a 3D model is created by curing liquid resin with a laser.

SLS: Selective Laser Sintering. A rapid prototyping technique whereby a 3D model is created by sintering plastic powder with a laser.

Solid Designer: 3D modelling package.

Stereo lithography: The process of using SLA as above.

Unigraphics: 3D surface and solid modelling package developed by EDS.

UNIX: Shareware workstation operating system.

VRML: Virtual Reality Mark-up Language – a file format for the viewing of three dimensional images.

Web 3D: The ability to view 3D images interactively on the internet.

Workstation: In recent years the boundaries between PCs and Workstations have become ever more blurred. However it might be classified as a hardware platform which exceeds the requirements of a computer for domestic use. The is typically characterised by fast/dual processing, large amounts of RAM (in excess of 250MB), specialised graphics cards and large amounts of hard disk storage (in excess of 1GB).

WWW: World wide web.

APPENDICES

to the document

The Impact of Three Dimensional Digital Modelling Media on the Modes of Communication used by Industrial Designers

NINA CHRISTINE WARBURTON





A thesis submitted in partial fulfilment
of the requirements of the
University of Northumbria at Newcastle
for the degree of











DOCTOR OF PHILOSOPHY

School of Design
University of Northumbria at Newcastle

November 2001

TABLE OF CONTENTS

Contents	i
List of figures.....	iv
1.0 FORMATIVE RESEARCH	2
1.1 Learning / Teaching Process	2
1.2 Learning Process	2
1.2.1 Learning Process Worksheets	3
1.2.2 Learning Process Images	6
1.2.3 Diagram Cards	9
1.3 Teaching Process	17
1.3.1 Teaching Process Worksheets	17
1.4 Formative Case Studies	19
1.4.1 Formative Case Study 1: Seaward Electronics 	19
1.4.2 Formative Case Study 2: Thwaites Breweries 	21
2.0 CASE STUDIES & CASE STUDY ANALYSIS	24
2.1 Media types 	24
2.2 Case Study 1: Bi-Liquid Mixing System	25
2.2.1 Documentary Evidence	25
2.2.1.1. Index 	25
2.2.2 Project Summary	26

2.2.2.1. Pre-Design Stage		27
2.2.2.2. Concept Generation Stage		28
2.2.2.3. Design Development Stage		30
2.2.2.4. Specification Stage		32
2.2.2.5. Troubleshooting Stage		35
2.2.3 Process Summary		37
2.3 Case Study 2. Soulagil		38
2.3.1 Documentary Evidence		38
2.3.1.1. Index		38
2.3.2 Project Summary		38
2.3.2.1. Pre-Design Stage		40
2.3.2.2. Concept Generation Stage		41
2.3.2.3. Design Development Stage		42
2.3.2.4. Specification Stage		44
2.3.3 Process Summary		47
2.4 Case Study 3: Medis		47
2.4.1 Documentary Evidence		47
2.4.1.1. Index		48
2.4.2 Project Summary		48
2.4.2.1. Pre-Design Stage		50
2.4.2.2. Concept Generation Stage		51
2.4.2.3. Design Development Stage		53

2.4.2.4. Specification Stage		55
2.4.3 Process Summary		57
2.5 Peer Review		59
2.5.1 Questionnaire		59
2.5.2 Questionnaire responses		60
2.6 Distribution Maps		67
3.0 PUBLISHED MATERIAL		72
3.1 A Heuristic Model for Digitally Integrated Design		72
3.2 Digital Integration & Designer Tactics		84

LIST OF FIGURES

<i>Number</i>	<i>Page</i>
Fig. 1. Example of a learning process worksheet.	4
Fig. 2. Example of a learning process worksheet	5
Fig. 3. Wire-frame view of teasmade base	6
Fig. 4. Wire-frame view of main body, storage containers and tea brewer	7
Fig. 5. Wire-frame view of teapot	7
Fig. 6. Shaded view of teapot	8
Fig. 7. The final model. Wire-frame view (left) and photo-realistic render (right).....	8
Fig. 8. Introduction card	9
Fig. 9. Explaining the software work space.....	9
Fig. 10. Explaining how to open the software	10
Fig. 11. Explaining the different elements of the modelling window.....	10
Fig. 12. Explaining various ways of moving and viewing the model.....	11
Fig. 13. Introducing the concept of curves.....	11
Fig. 14. Illustrating that curves and lines are a combined entity.....	12
Fig. 15. Making curves and lines active and inactive.....	12
Fig. 16. Manipulating the curve/line using control points.....	13
Fig. 17. Using the mouse to manipulate curves/lines	13
Fig. 18. Rotating and scaling curves/lines	14
Fig. 19. Introducing the concept that the curve/line is the starting point for most surfaces	14
Fig. 20. Revolving the curve/line to make a surface	15
Fig. 21. Building a surface up over two curves/lines	15
Fig. 22. Building a surface up over multiple curves/lines	16
Fig. 23. Extruding a curve/line to make a surface	16
Fig. 24. An example of a teaching process worksheet	18

Fig. 25. Table illustrating the breakdown of, and abbreviations for, media types used in the case study analysis	24
Fig. 26. Bi-Liquid Mixing System: Case Study Index	26
Fig. 27. Final mouldings for Bi-Liquid Mixing System.....	27
Fig. 28. Sketches from the brainstorming session	28
Fig. 29. Left & Middle: Boards from Initial Concept Presentation. Right: Computer Visualisation from Initial Concept Presentation	29
Fig. 30. Presentation Illustration explaining the two ‘Design Development A’ concepts ...	30
Fig. 31. Computer Visualisation showing left: the favoured concept and right: the principle of the concept.....	30
Fig. 32. Preliminary 2D drawings for toolmakers and moulders	31
Fig. 33. Revised Concept: ‘Design Development B’	31
Fig. 34. Stills from the animation illustrating ‘Design Development C’	32
Fig. 35. Polyurethane casting taken from SLA master.....	33
Fig. 36. First issue technical drawings: created directly from 3D modelling data	34
Fig. 37. Computer Visualisation of proposed handle	34
Fig. 38. Left: SLS rapid prototype parts. Middle & right: Off tool plastics.	36
Fig. 39. Stills from animation produced for the world affiliates meeting.....	36
Fig. 40. Computer Visualisation of the final design proposal.....	40
Fig. 41. Worksheets from initial brainstorming session.....	41
Fig. 42. Initial Concept Sketches and GA’s.....	42
Fig. 43. Boards from Initial Concept Presentation	42
Fig. 44. Concept regeneration through the use of sketches.....	43
Fig. 45. Concept regeneration through the use of GA’s.....	43
Fig. 46. Phase 1 presentation boards	43
Fig. 47. Appearance models	44
Fig. 48. Computer Visualisations (left: without label. Right: with label).....	44
Fig. 49. Concept development. Left: AutoCAD drawing. Right: Presentation Illustration.....	45
Fig. 50. Concept development. Left: Computer Visualisation. Right: Appearance Model.....	45

Fig. 51. Further concept development. Left: Sketches and right: Hand drawn GA	46
Fig. 52. Further concept development. Left: 2D AutoCAD drawings and right: Computer Visualisation.....	46
Fig. 53. Final specification drawings for case and actuator	46
Fig. 54. Existing unit (left) and right: Medis unit.....	50
Fig. 55. Left: Kintore Health Centre. Right: Inverurie Health Centre	52
Fig. 56. Left: Contextual Model of Inverurie Health Centre Middle: Full size configuration rigs. Right: Initial configuration sketches.....	52
Fig. 57. Presentation boards for initial presentation	53
Fig. 58. Left: development drawing of asymmetric concept. Middle: Scale model. Right: Full size test rig.	53
Fig. 59. Left: Full size sketch model. Middle: Full size appearance model. Right: Internal components in 3D.....	54
Fig. 60. Left: 3D concepts. Middle: The concepts in-situ. Right: Materials and finishes....	54
Fig. 61. Left: Working out details using sketches. Right: 3D view of the finished design.....	55
Fig. 62. Left: 3D view of the finished design. Right: 2D drawings from the 3D data	56
Fig. 63. Proposals for the Medis logo	56
Fig. 64. Left: Proposal for the Medis logo. Right: The final logo.....	56
Fig. 65. Building the prototype	57
Fig. 66. Installing the prototype	57
Fig. 67. Questionnaire for Heuristic Map peer review feedback	59
Fig. 68. Distribution map cross-referencing reasons for use with media types. Digital media are shown by red, traditional by green.	68
Fig. 69. Distribution map illustrating the relationship between communication and media types.....	69
Fig. 70. Distribution map illustrating the relationship between the media types and timeline attributes.....	70
Fig. 71. Hand rendering of 'Soulagil' Concept	76
Fig. 72. Final computer visualisation.....	76
Fig. 73. Initial sketches of Medis concept	77

Fig. 74. Final Medis prototype	77
Fig. 75. Drawing of initial Bi-Liquid Mixing System concept	78
Fig. 76. Still from Bi-Liquid Mixing System animation.....	78
Fig. 77. Integration model	80
Fig. 78. White models of ‘Soulagil’ Concept	87
Fig. 79. Final computer visualisation.....	87
Fig. 80. Full scale model of Medis concept.....	88
Fig. 81. Final Medis prototype	88
Fig. 82. Computer visualisation of Bi-Liquid Mixing System concept.....	89
Fig. 83. Still from Bi-Liquid Mixing System animation.....	89
Fig. 84. Integration Map.....	92

Appendix 1: Formative Research

1.0 FORMATIVE RESEARCH

1.1 Learning / Teaching Process

In order to become familiar with one of the pieces of software (Alias) to be used as part of the research programme, the researcher undertook a process of learning the software, immediately followed by teaching it to another. The objective of this process was one of linear reinforcement. The process was documented via a series of worksheets; the learning process resulted in the production of a set of what were called 'diagram cards'. A series of cards which tried to summarise the key concepts of the software and present them to the student in a more user friendly and useful manner than they were presented in the software manual.

1.2 Learning Process

This section concentrates on the learning of Alias Studio, the initial 3D modelling research software. The learning process was carried out through the building of a project model, this was based on the principle that it is more appropriate to learn 'on the job', as designers learn by doing, rather than being taught out of context. The learning project chosen was the 'samovar' teasmade, which had comprised part of my undergraduate degree submission. It was appropriate as a learning project as it had already been designed, a model had already been built and it had range of form and component interaction requirements. Worksheets were utilised to provide continual documentation of the process.

'Samovar' combines a number of components ranging from highly geometric to more complex, free form curvature. This combination made the product ideal as a learning model as the more simple geometries could be quickly modelled, building understanding and confidence with tangible results. The initial learning sessions were fully supervised, but it soon became apparent that the intensity of supervision was too high; learning was being achieved by rote. The approach was modified to become

more investigative, with discussion of the modelling problem before a number of routes were attempted to try to solve it, which appeared to result in a more effective understanding of the process.

The learning process progressed very well, but the modelling process was not always smooth with some modelling problems generating vigorous debate. Stumbling blocks occurred with certain geometries, which on first impressions appeared 'made' for Alias. This led to a modification of the modelling activity, where tactics were worked through using sketches and drawings instead of working directly onto the screen from a technical drawing or an existing model. Working out the geometry on paper before attempting to model it proved to be highly effective. After approximately sixty hours the wire-frame was complete and the documented learning process at an end, the model ready for rendering and presentation.

1.2.1 Learning Process Worksheets

This section contains a few examples of the worksheets employed as part of the learning process. They illustrate of the range of approaches used and how the documentation changed over the period of learning.

Alias - Learning Process - Progress Worksheets

Session 1-2
 Date: 7/3/93 Time Started: 11:30 Time Finished: 6pm
 Project: TETRAHED
 Reference Information: TechDex + Model.
 Start Point: Flat Base
 End Point: Flat Base - much smoother
 Goal for the Session: Base

Progress Notes

I have come to the model from after the extreme frustrations of the past few sessions. I have decided that the only way to solve the problems with the base that I have, i.e. the dark patch on the trapet stand is to delete the other and draw it again from scratch. →

An OK session. There are still a lot of things to overcome with the base but at least I feel that I am making some progress now, whereas before I was just very very frustrated.

Thinking as it former however, I decide not to delete the whole thing and start from scratch, but to duplicate a profile curve and draw over the top.

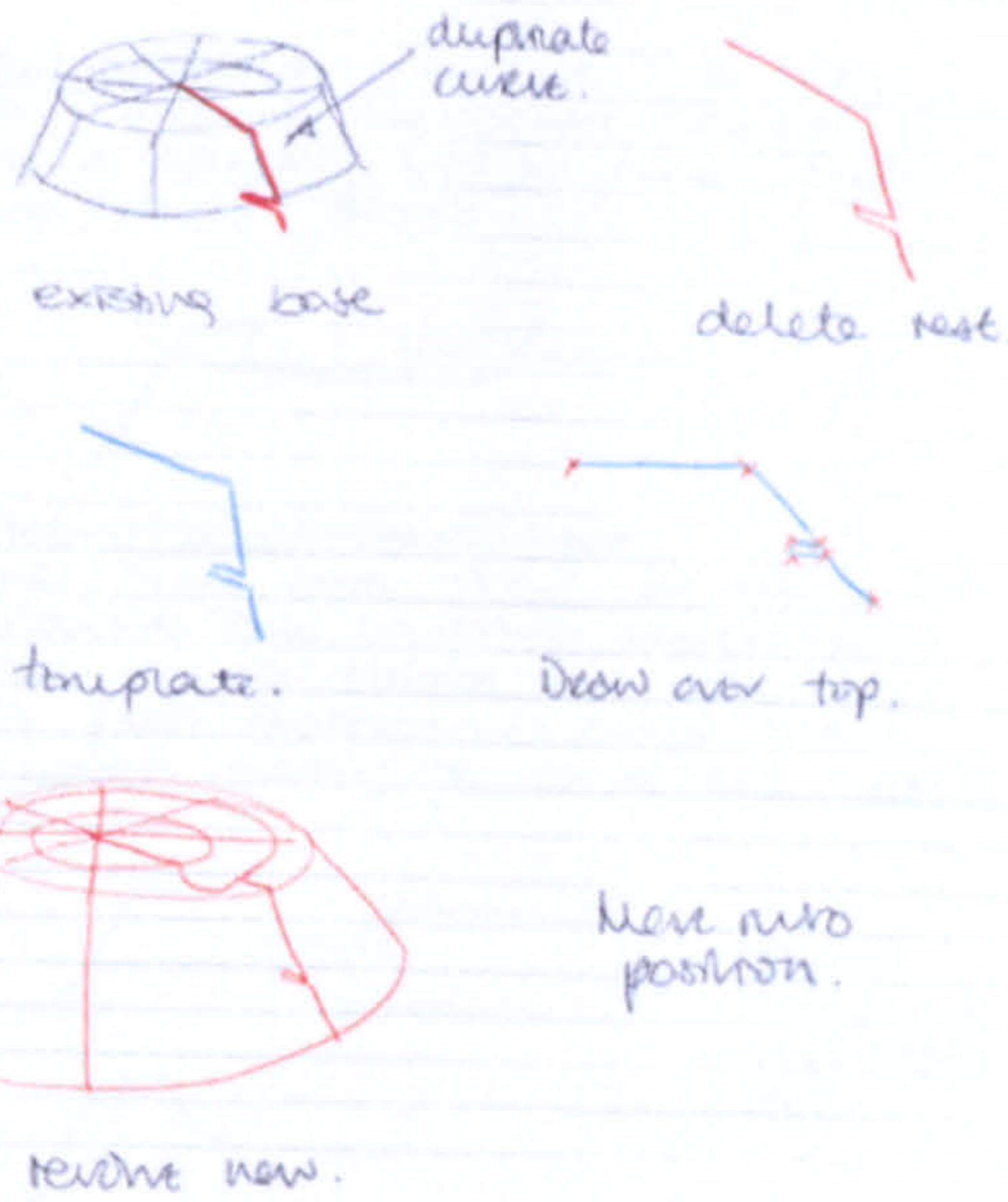

By a process of scaling, moving and duplicating curves to check accurately the position of components I was able to get the trapet stand part to the correct position.

The next problem was to correct the apparent lack of surface at the inner curve of the body component.



I duplicated the top curve, copied it and moved the copy down - then patched between.

and also to change the angle at the top near pinholes to correspond with the body component.



This was done using rotate.

I then made surfaces on top of the top + mill pinholes - in order to complete this aspect of the base.



They looked like this.



First I duplicated the inner curve.



I then created a separate curve to link the two holes.

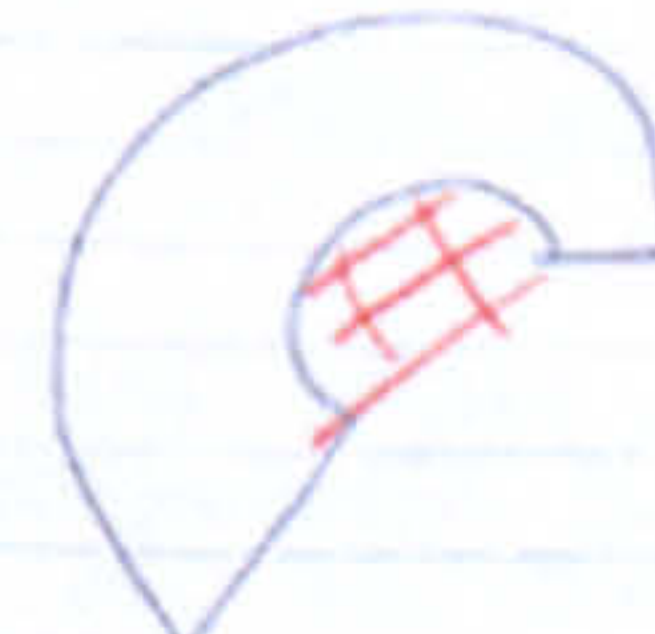

Then patched between.

Fig. 1. Example of a learning process worksheet.

Date 31/3/93 Time Started 10:30 Time Finished 12:30
 Project TEASMMIDE 1:30 3:30

Reference Information: MODEL + TECH DEG.

Start Point: Rinet base.

Goal: Base recess + buttons

Final Point: Base recess.

Progress Notes:

The first task is to redo the recess at the top edge of the base.

I initially tried this by making another few and comparing a team. However, because of the tangencies involved ~~to~~ I could not manage it without leaving a sort of 'ridge' behind. So, how to do it?

Eventually managed the base recess. This has highlighted some important worries about the system being unable to cope with tangency & therefore possibly determining design?

We tried to drop the ws into the correct positions to create the recess but underestimated just how difficult this would be. It was nearly impossible when we decided to forget this approach.

New approach: To use the trim but extend the trim shape so it came back and under the trapet stand.

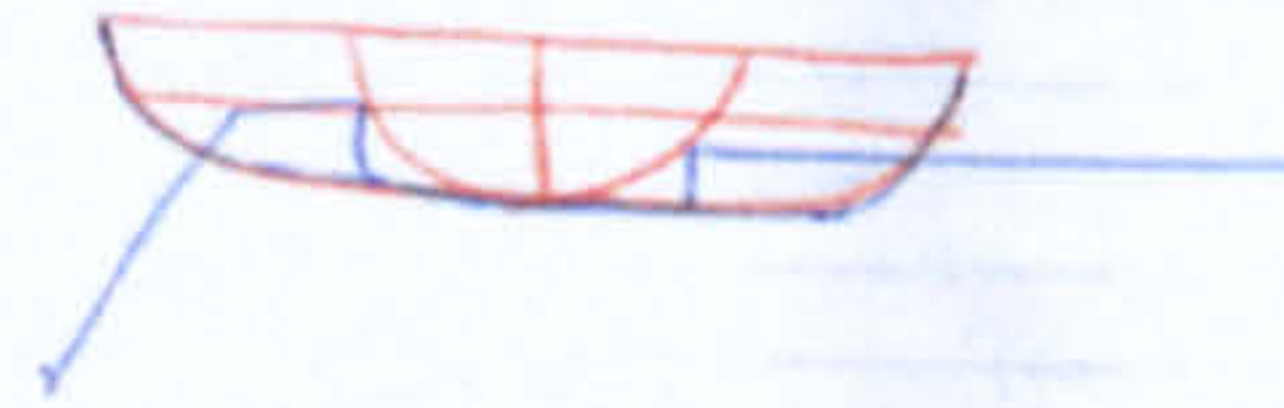

The trapet stand bit. The trim can then be executed leaving the lipping underneath the trapet stand bit which is first detached and then moved back to cap the lipping off.



This shape would then be used to trim the plinth away.

Problem ① - How to create this shape?



Draw prim circle in front elev. detach to a quarter shape

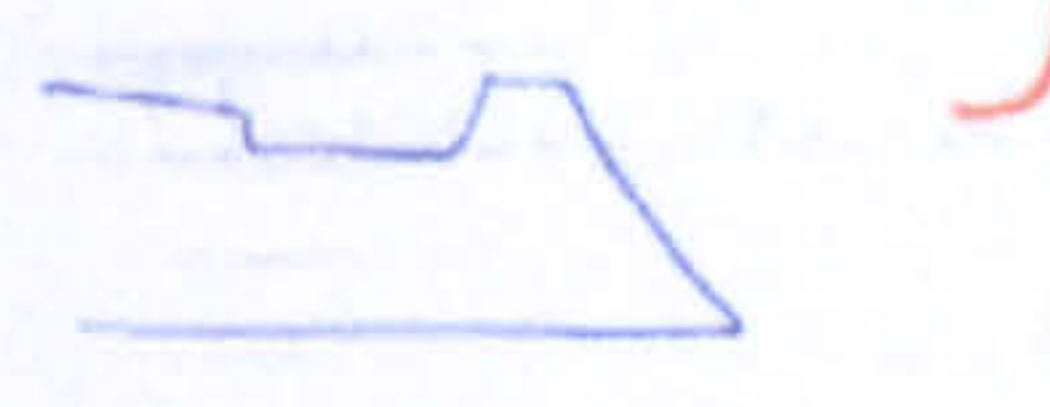

Rotate around

Umm maybe not. What about ...



Draw a new curve between the two quarter circles. Attach using connect.

Copy and scale inwards.

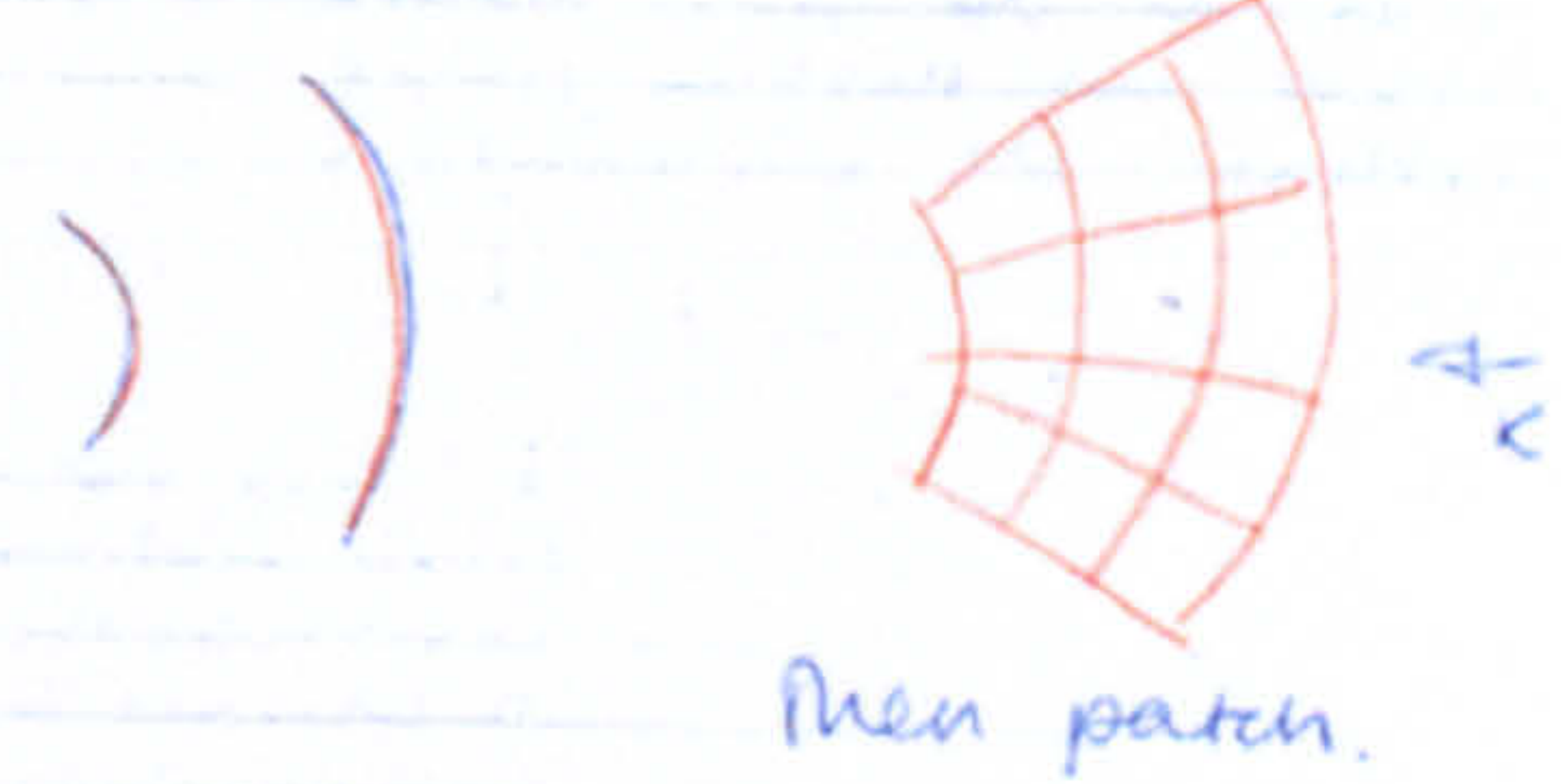

Then patch.

If looking from the right window there was a considerable amount of blank going on in the surface

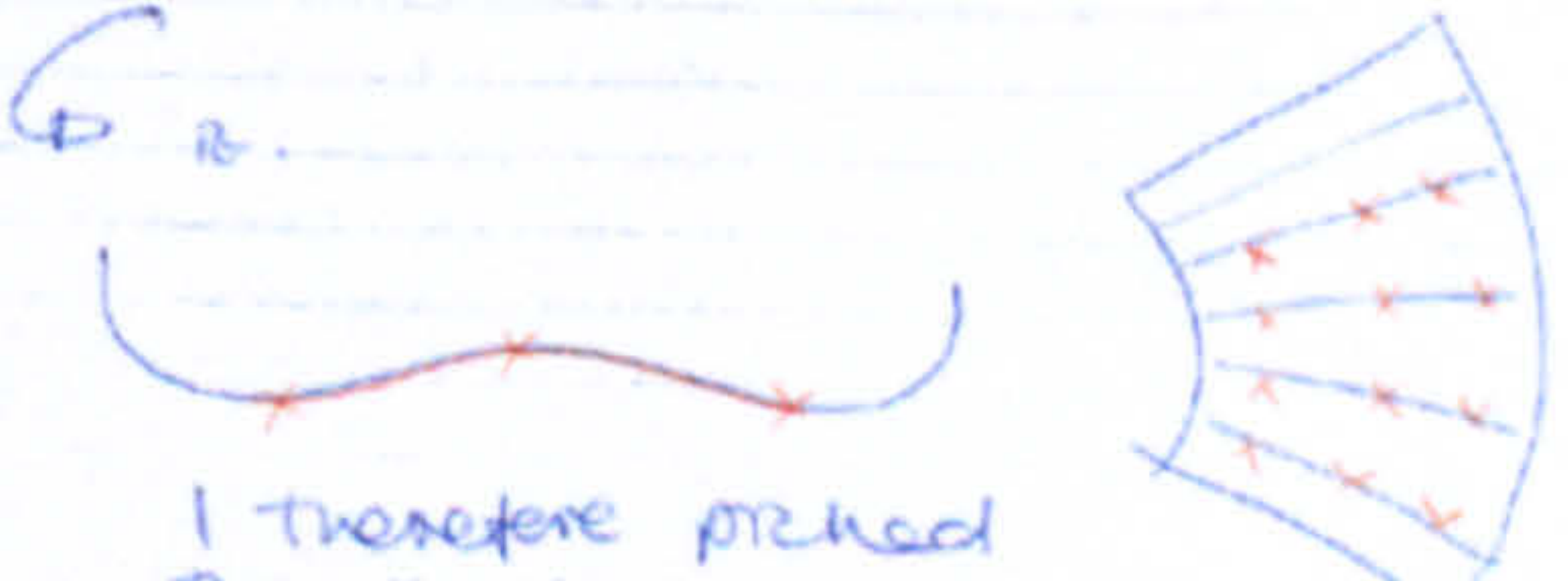

I therefore picked the offenders from the top inwards

Fig. 2. Example of a learning process worksheet

1.2.2 Learning Process Images

The following images are a selective representation of relevant aspects of the learning process, marking significant points of interest or progress within the project.

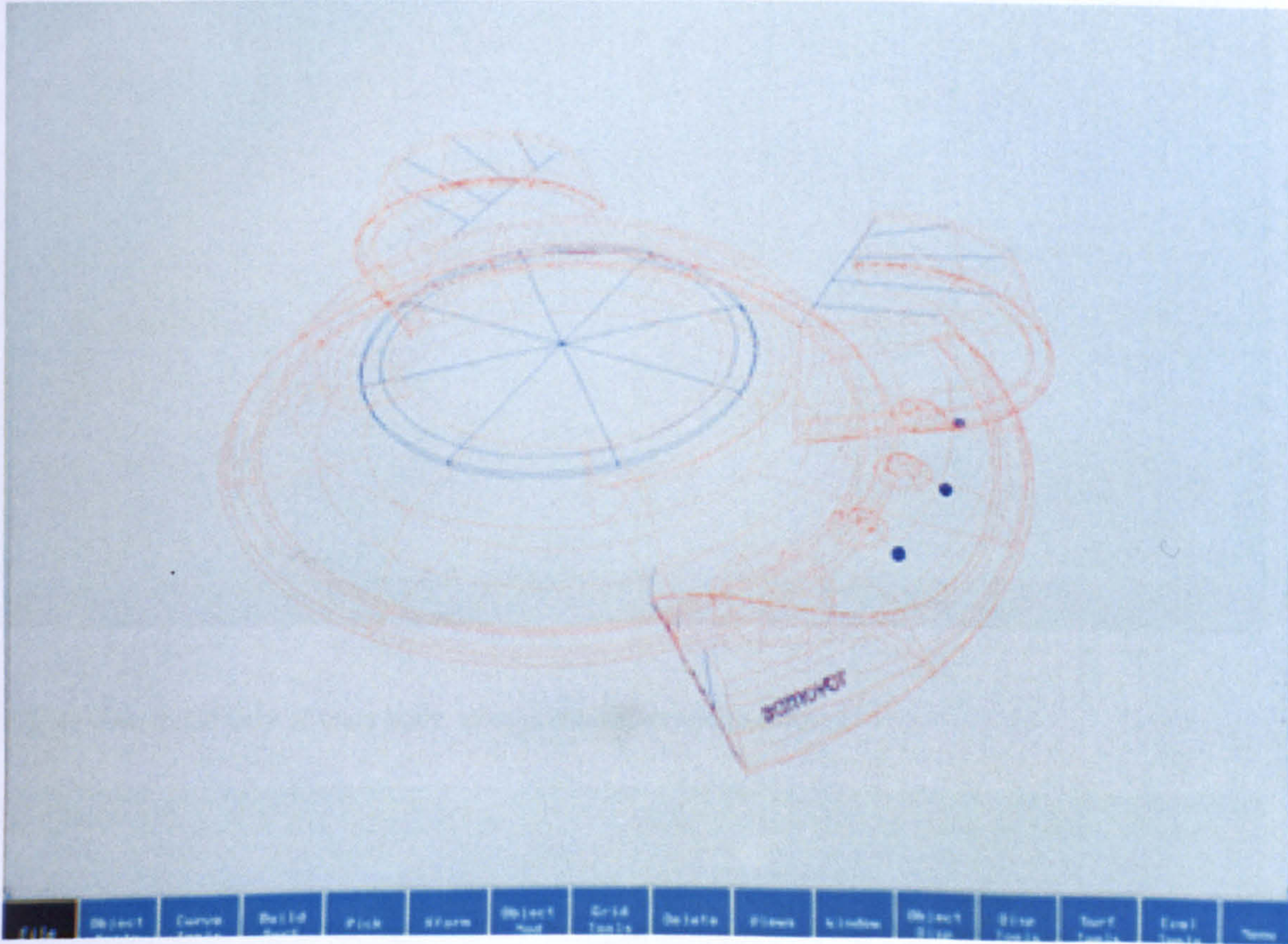

Fig. 3. Wire-frame view of teasmade base

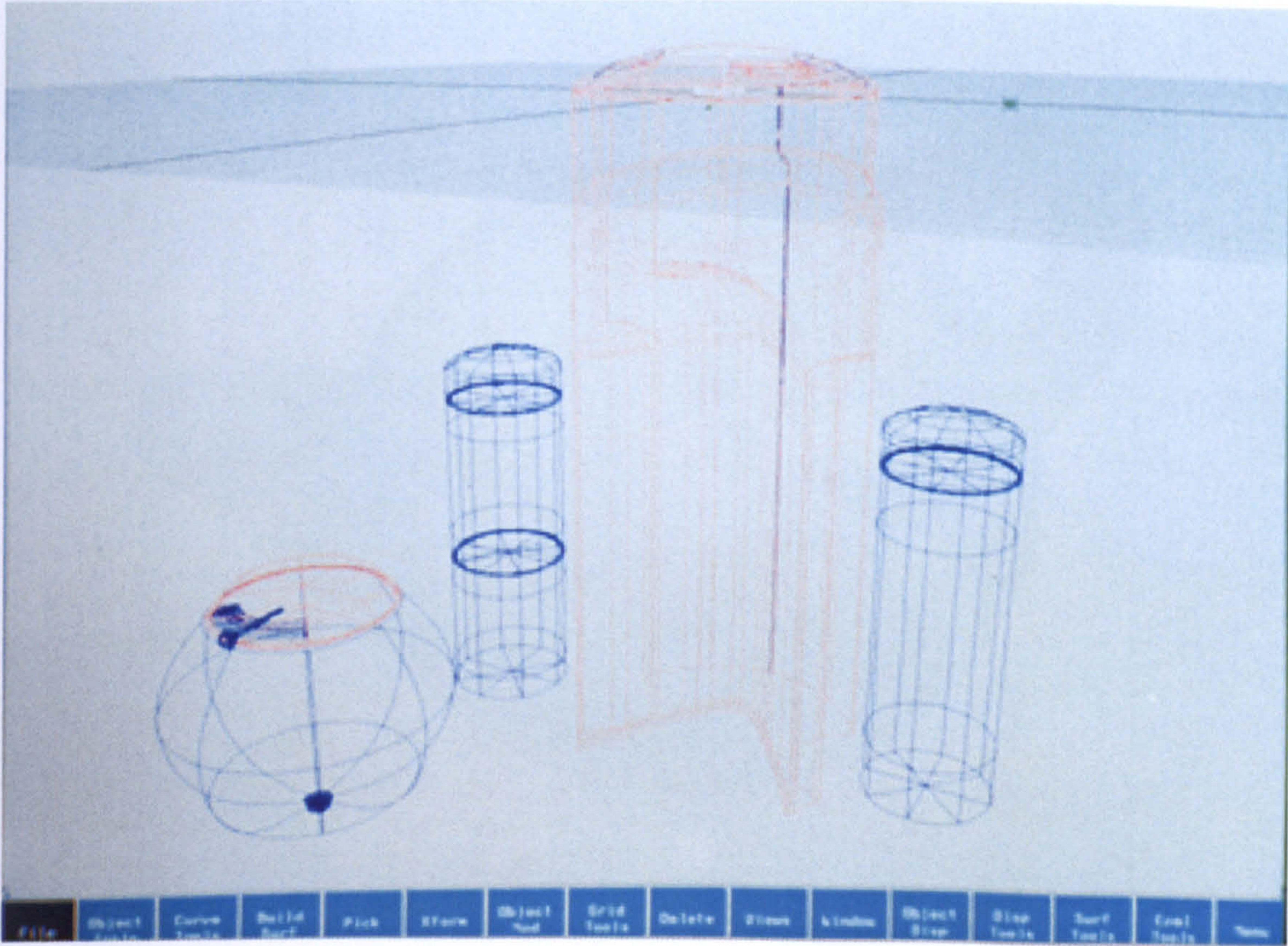

Fig. 4. Wire-frame view of main body, storage containers and tea brewer

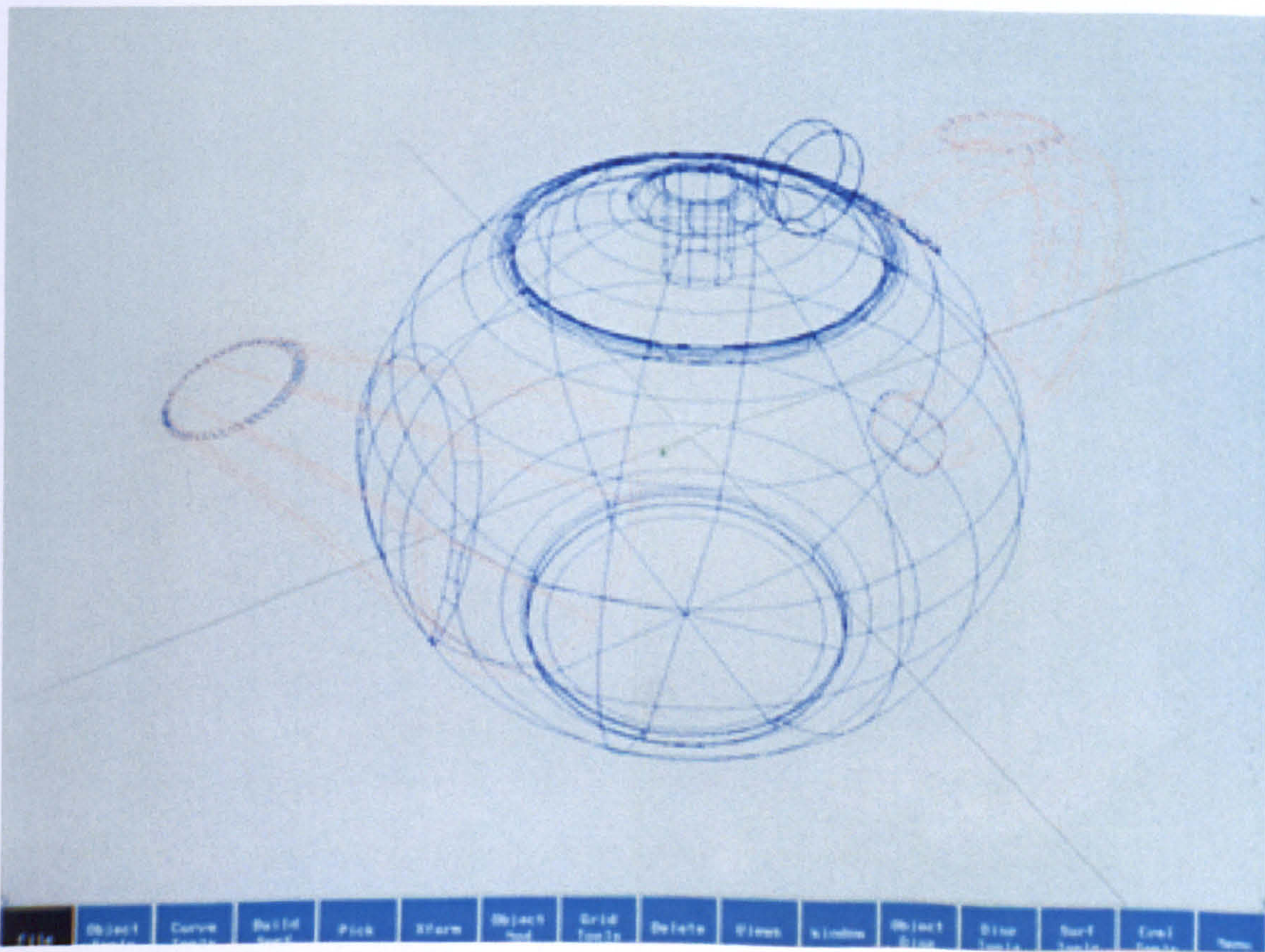

Fig. 5. Wire-frame view of teapot



Fig. 6. Shaded view of teapot

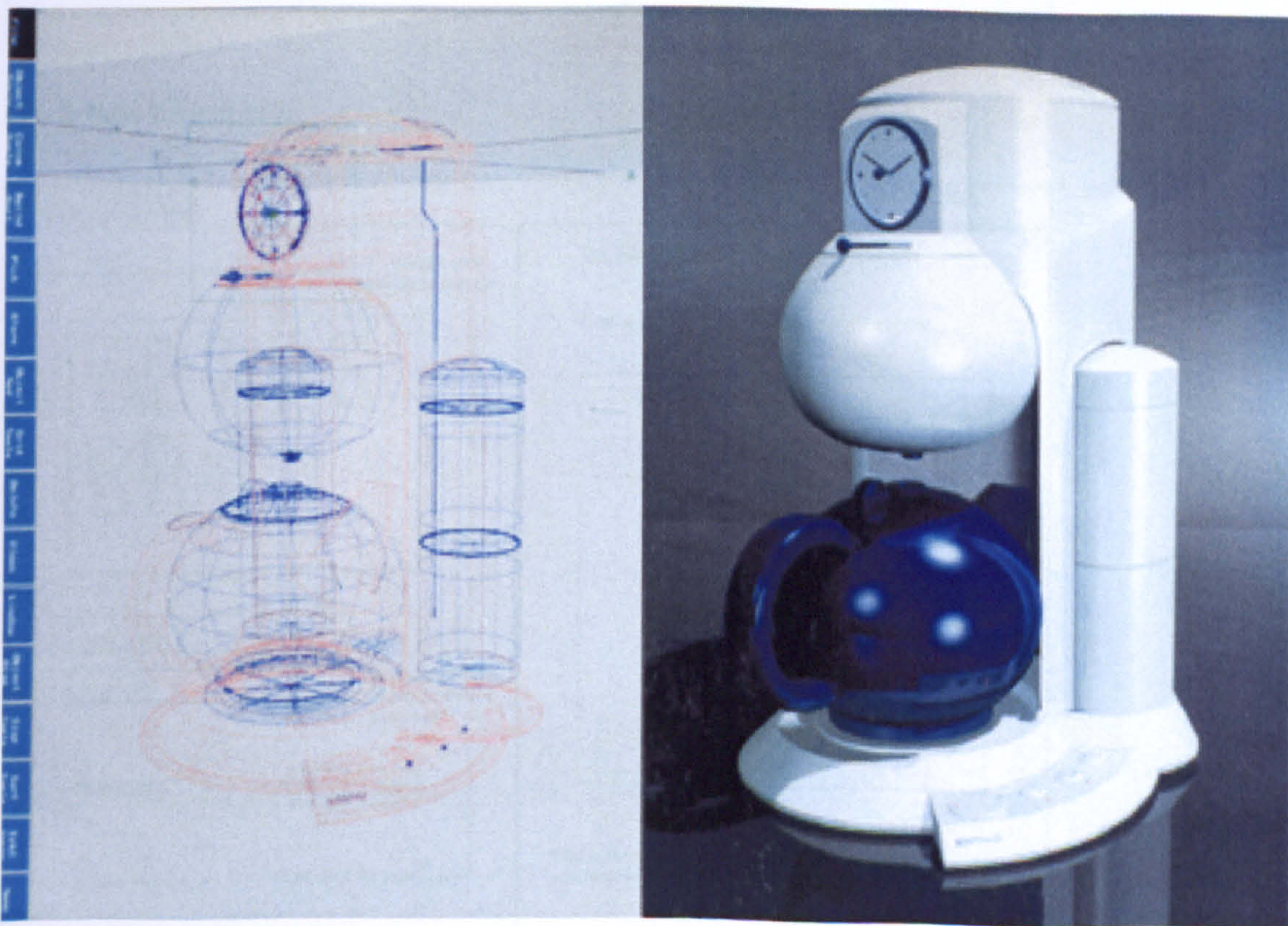

Fig. 7. The final model. Wire-frame view (left) and photo-realistic render (right)

1.2.3 Diagram Cards

This series of cards are an attempt to illustrate the key concepts of the software in order that they might assist a student in learning the software. They were used to both familiarise the student with the concepts before learning and also as a quick reference during learning.

INTRODUCTION	<p style="text-align: right; margin: 0;">1. WHAT IS 3D SURFACE MODELLING?</p> <p>As a designer you are already familiar with modelling using clay, wood or foam. With virtual modelling, you will work on curves and surfaces with modelling tools in a simulated 3D environment to create 3D models.</p> <p>Imagine that you are working with wire.</p> <p>First you place wires that determine the basic shape of the object - by adding more wires the result is a wire mesh that represents the shape. You then cover the wires with a skin of whatever colour and/or material you require. Finally you set up your lights and take a picture.</p> <p>This is essentially how a 3D surface modeller works.</p> <p>These cards are designed to be utilised in conjunction with the teaching of Alias. They are not designed to replace a tutor, but to prompt you in the three basic areas defined as.</p> <ul style="list-style-type: none"> • Getting In • Moving Around • Modelling <p>They should help to generate an understanding of the geography of the system. The principle behind them is that they are visual in nature as a sort of quick reference system, rather than binding the student with words and descriptive text - like this!</p> <p>All functions on Alias are controlled by a combination of the mouse and the keyboard - but primarily the mouse.</p> <ul style="list-style-type: none"> • A single click with the left key on any icon will activate it and make it usable - Active Icon - Yellow • A double click is used to open folders and access further parts of the system, ie. the Alias programme itself <p>The various buttons on the mouse control the movements of the cursor, this is extremely useful when you start modelling</p> <ul style="list-style-type: none"> • LEFT KEY - ALL FUNCTIONS / ALL DIRECTIONS • MIDDLE KEY - HORIZONTAL MOVEMENT • RIGHT KEY - VERTICAL MOVEMENT
---------------------	--

Fig. 8. Introduction card

GETTING IN	<p style="text-align: right; margin: 0;">2. NEW MODEL</p>
-------------------	--

1 Single click on research

3 Enter password using keyboard then enter

2 Single click on login

PERSONAL

login help

The Screen will go blank for a few seconds

Then a window called workspace will appear

This is the window from which you access the programme, edit files and move them around.

Fig. 9. Explaining the software work space

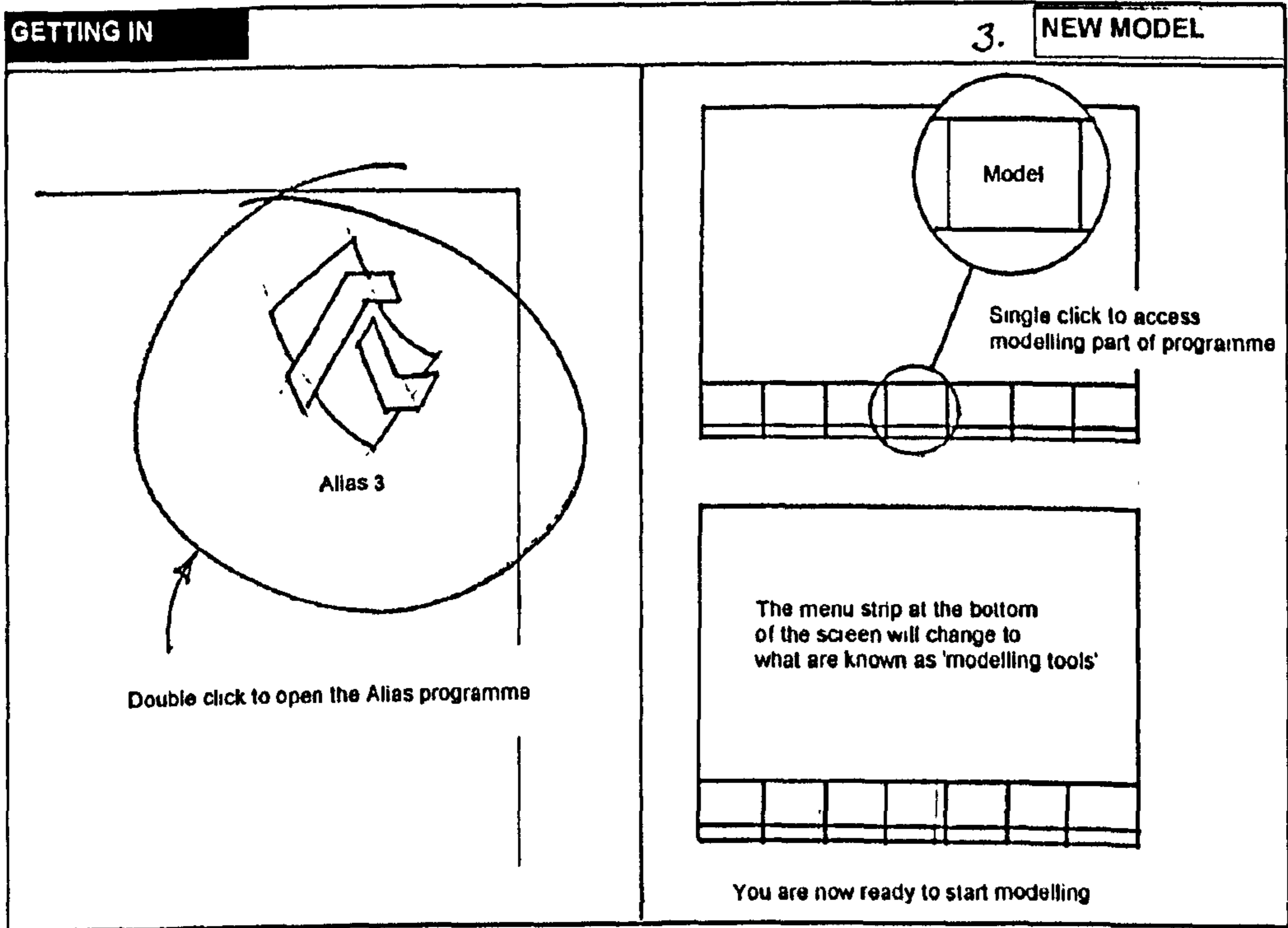

Fig. 10. Explaining how to open the software

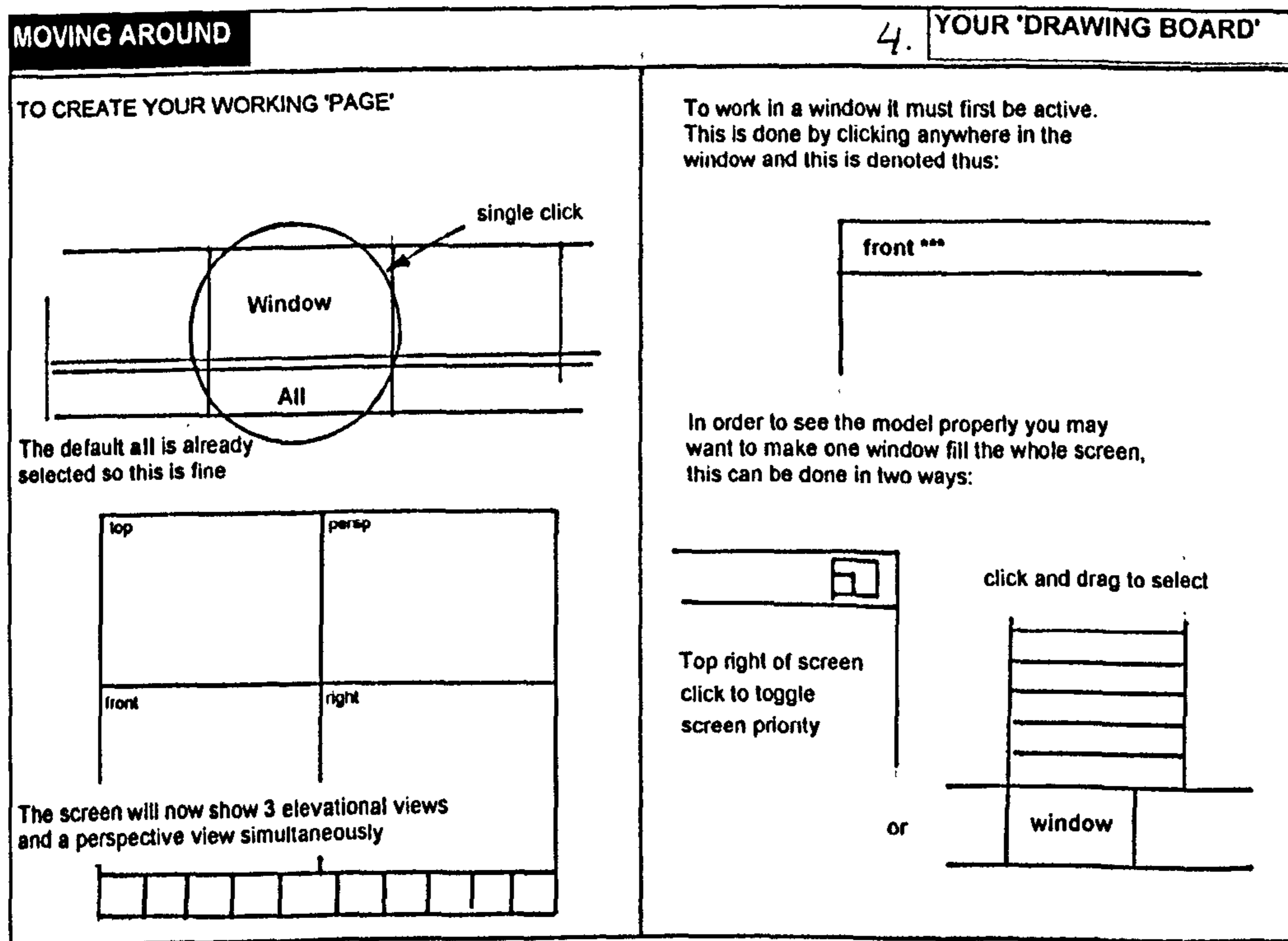
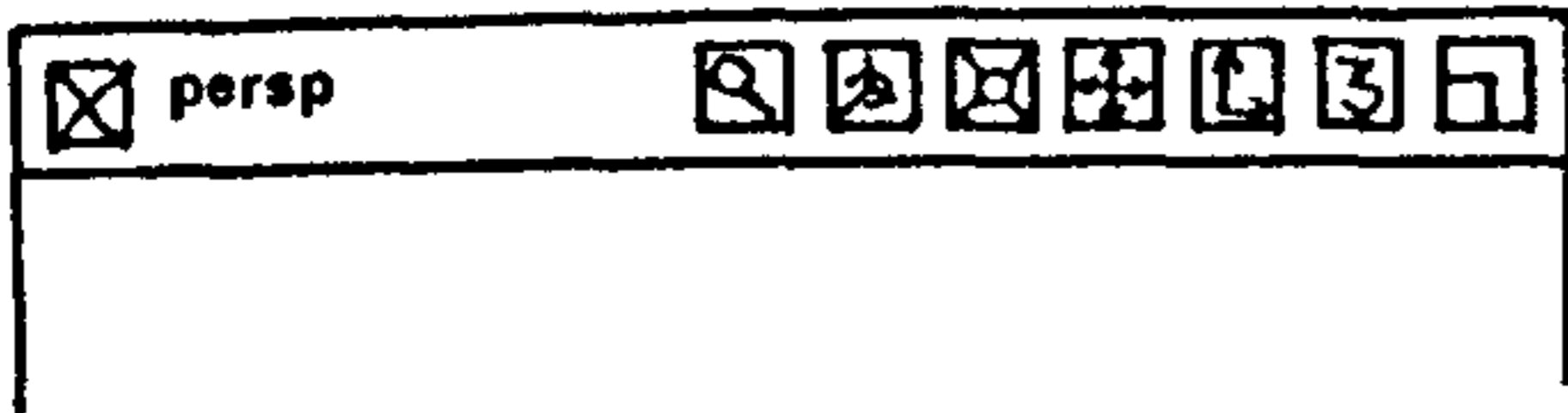

Fig. 11. Explaining the different elements of the modelling window

MOVING AROUND

5. 'VIEWING' YOUR MODEL



Apart from changing screen priority there are a number of ways of manipulating your view in order to view your model better. The most useful of these are tumble, dolly and track. They can be accessed from the icon bar (above) or the menu command line under views.

Tumble (can only be used in perspective window)

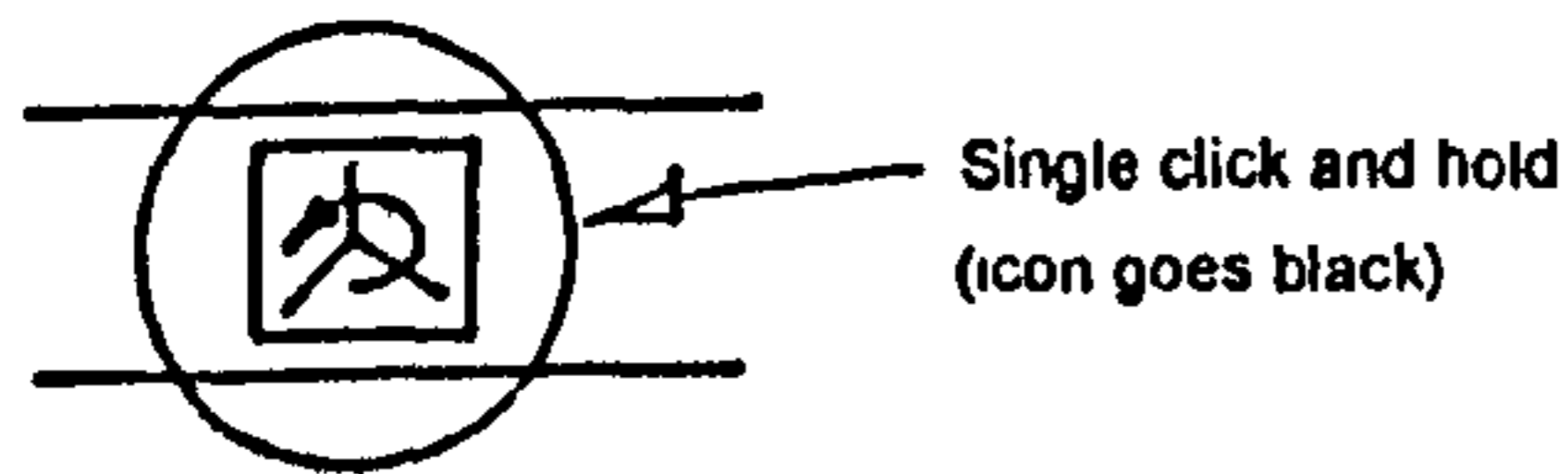

Move mouse left, right, up and down, view tumbles and when you are happy with the view, release the mouse button to confirm. Remember to try this using the horizontal and vertical priority mouse keys

Dolly, imagine that you are on a camera dolly - zooming in and out of the model

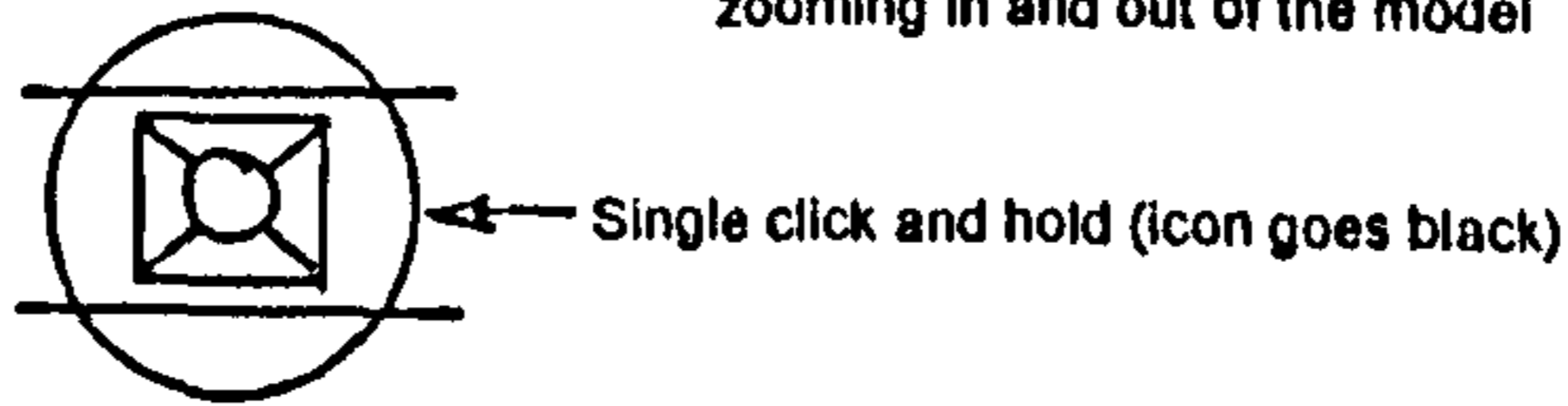

Move mouse left slightly and you will move away from the model at a steady rate, this is known as dollying out. Move the mouse constantly to the left and you will dolly out at an accelerated rate. Move the mouse to the right and you will move closer to the model, this is known as dollying in.

Track, moves the view across or up and down the screen.



In response to up, down, left and right mouse movement, the view shifts or tracks to follow the mouse. Remember you can constrain your tracking to vertical or horizontal only movement by using the right or middle mouse keys.

HELP - If at any time you lose control simply select views - reset and click in the modelling window

Fig. 12. Explaining various ways of moving and viewing the model

MODELLING

6. DRAWING A LINE

THE CONCEPT

Modelling with Alias starts by plotting a series of points these are known as *control vertices* or *cv's*

When you arrange a series of cv's its like plotting points on a graph, first you plot the points then Alias joins them in a smooth curve

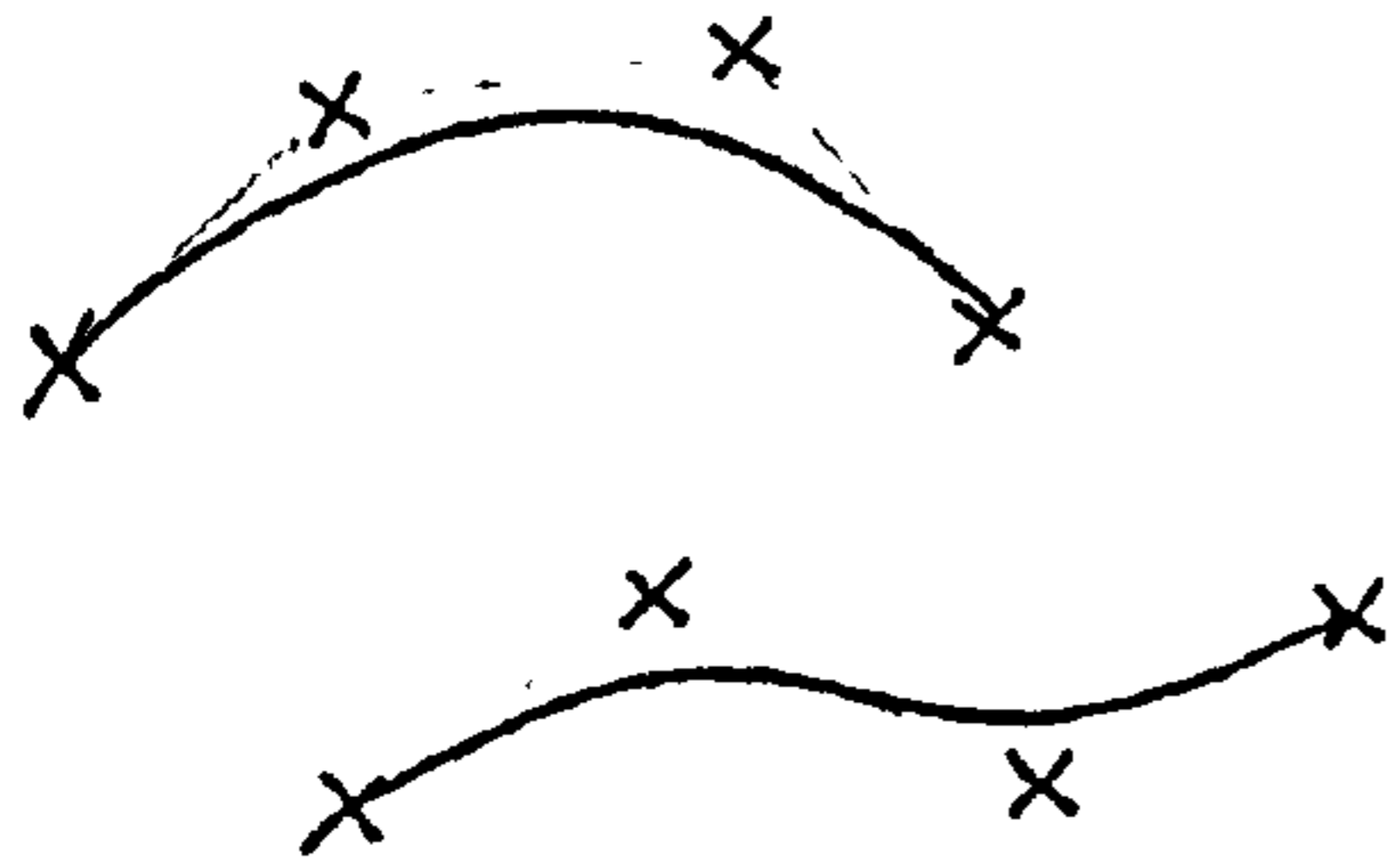

In Alias, all lines whether straight or curved, are known as curves.

TO DRAW A CURVE

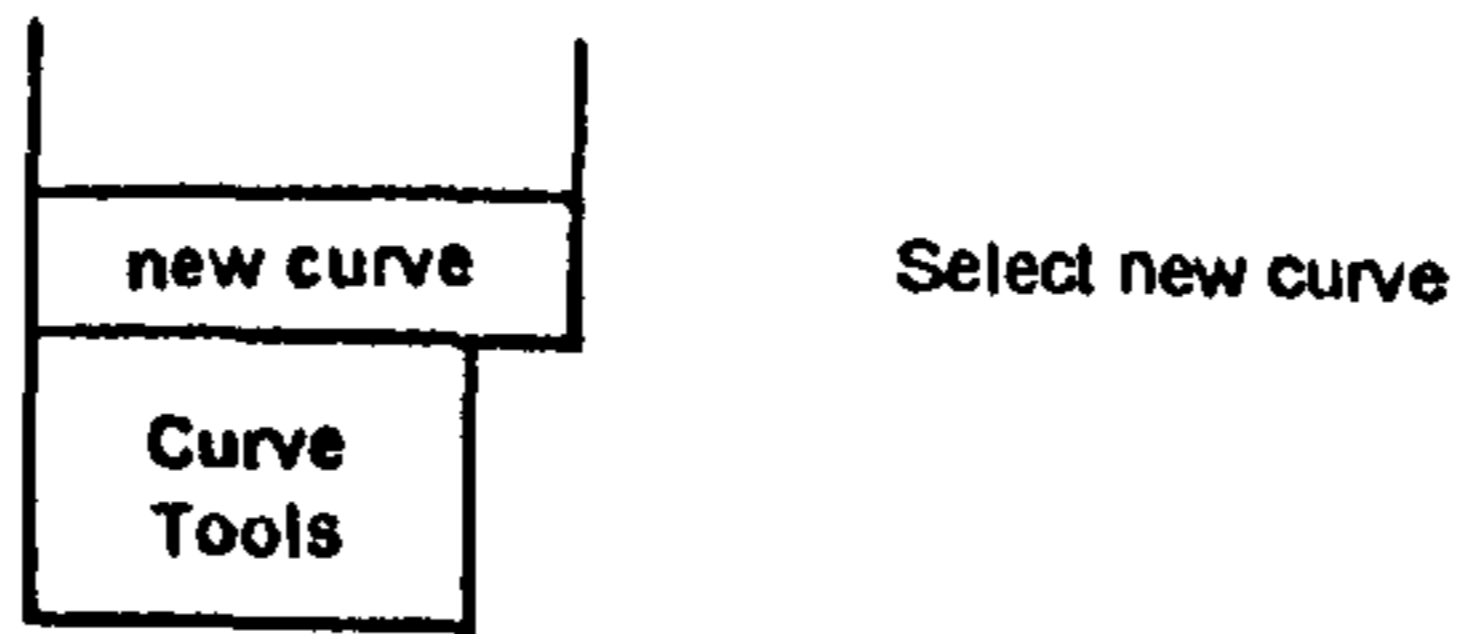

Then use the mouse to click in the modelling window and lay down a series of cv's. A smooth line is automatically drawn between the points with each cv exerting an influence on the curvature of the line

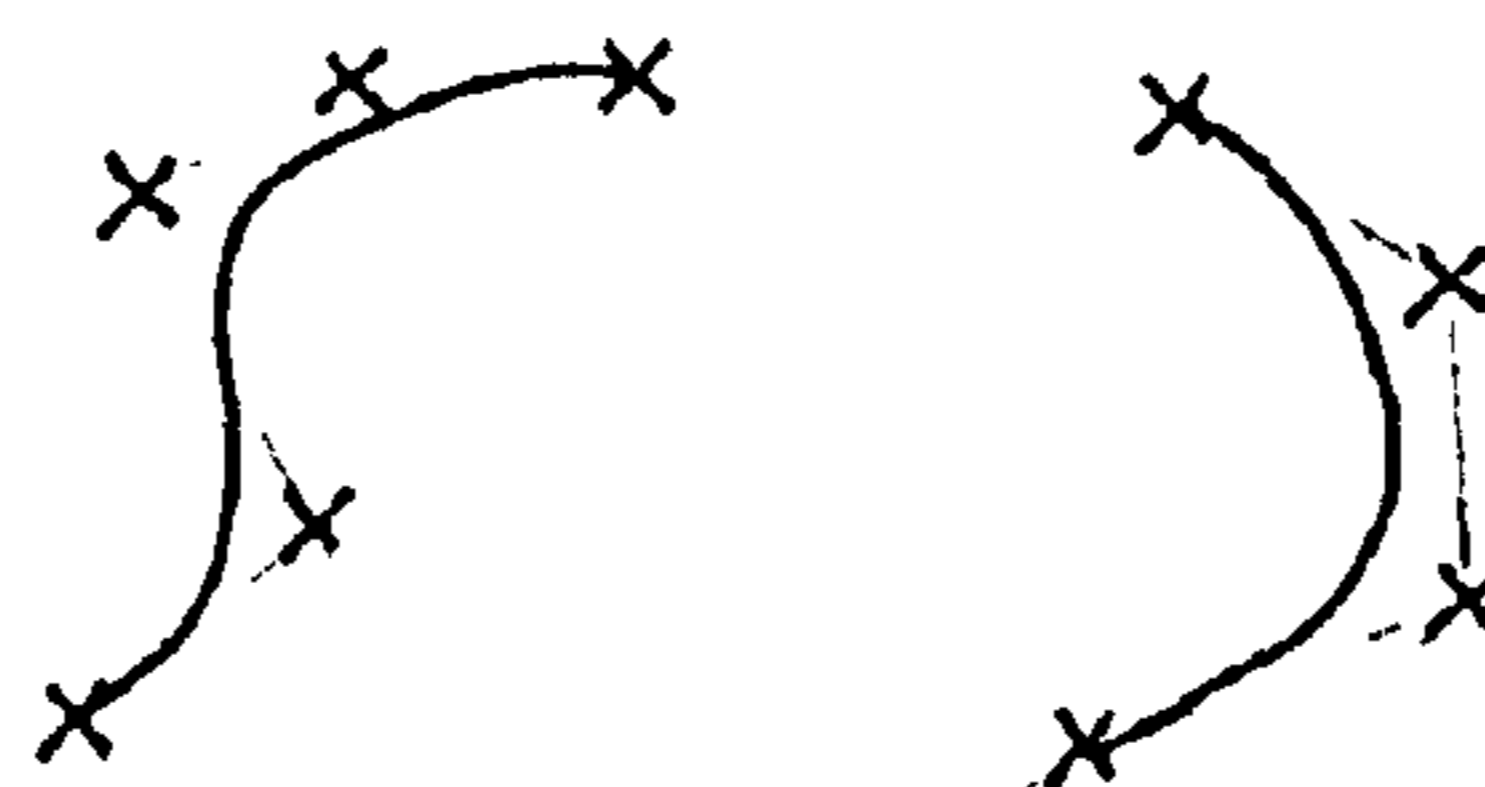

Only the beginning and end cv's automatically connect to the end of the line

Each curve must contain a minimum of 4 cv's

Fig. 13. Introducing the concept of curves



<p>MODELLING</p>	9.	<p>MANIPULATING THE LINE</p>						
<p>WHAT IF YOU WANT SHARP CORNERS ON THE LINE?</p> <p>The nature of splines are that they draw a smooth line between, but not running through points, there are ways of changing this, but the simplest for the moment is by using a tool called multiplicity</p> <p>This adds cv's on top of the existing ones picked therefore increasing the magnetism of the cv set</p> <p>The multiplicity settings are from 1 - 3</p> <p>1 - one cv, normal magnetism 2 - two cv's, more pull towards cv 3 - three cv's, hard corner at cv</p>		 						
	<table border="1" style="margin-left: auto; margin-right: auto;"> <tr> <td colspan="2" style="text-align: center;">MULTIPLICITY</td> <td style="text-align: center;">?_</td> </tr> <tr> <td style="text-align: center;">SAVE</td> <td style="text-align: center;">EXIT</td> <td style="text-align: center;">GO</td> </tr> </table>	MULTIPLICITY		?_	SAVE	EXIT	GO	<p>click on field to enter or change settings</p>
MULTIPLICITY		?_						
SAVE	EXIT	GO						
								

Fig. 16. Manipulating the curve/line using control points

<p>MODELLING</p>	10.	<p>MANIPULATING THE LINE</p>
<p>Things can only be manipulated when they are active so the pick command is constantly in use</p> <p>This is where you will start to use the X-form (transform) commands such as move, scale, rotate etc.</p> <p>MOVING A CV</p> 	<p>MOVING AN OBJECT</p> 	 
<p>Go to</p> 		<p>Click and hold and move</p>
<p>Click and hold anywhere in the window (not on the model) with the mouse and move it around - the cv will move and the curve will adjust to follow the pull of the cv</p>	<p>Remember to make use of the directional mouse keys</p>	

Fig. 17. Using the mouse to manipulate curves/lines

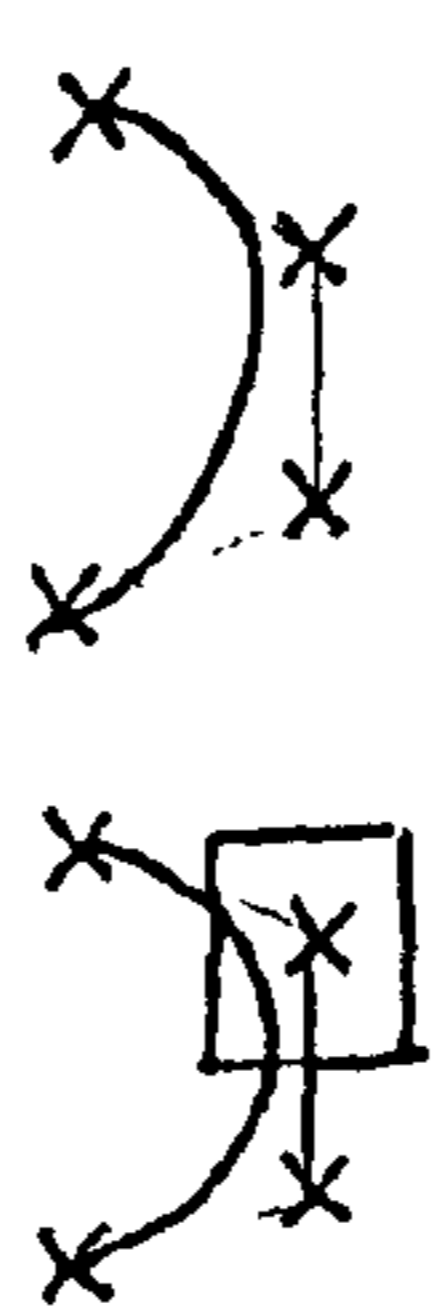
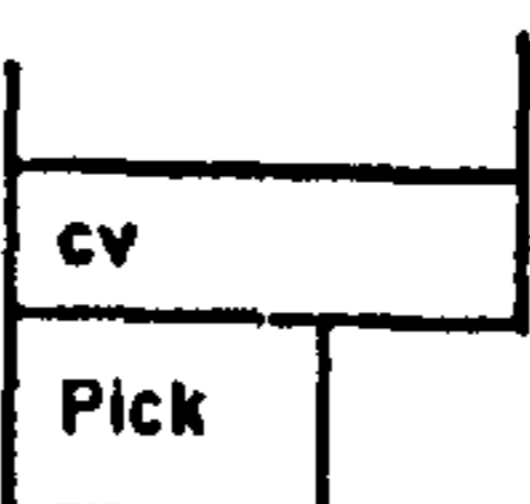
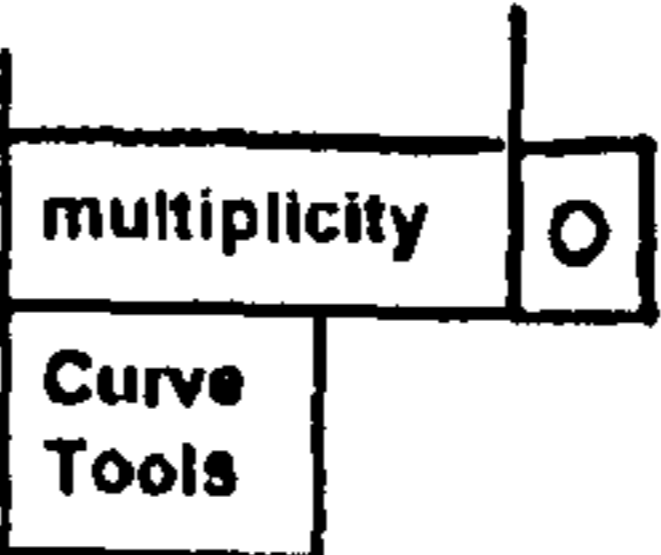
DRAWING A STRAIGHT LINE



Highlight grid in the right hand section of the menu bar

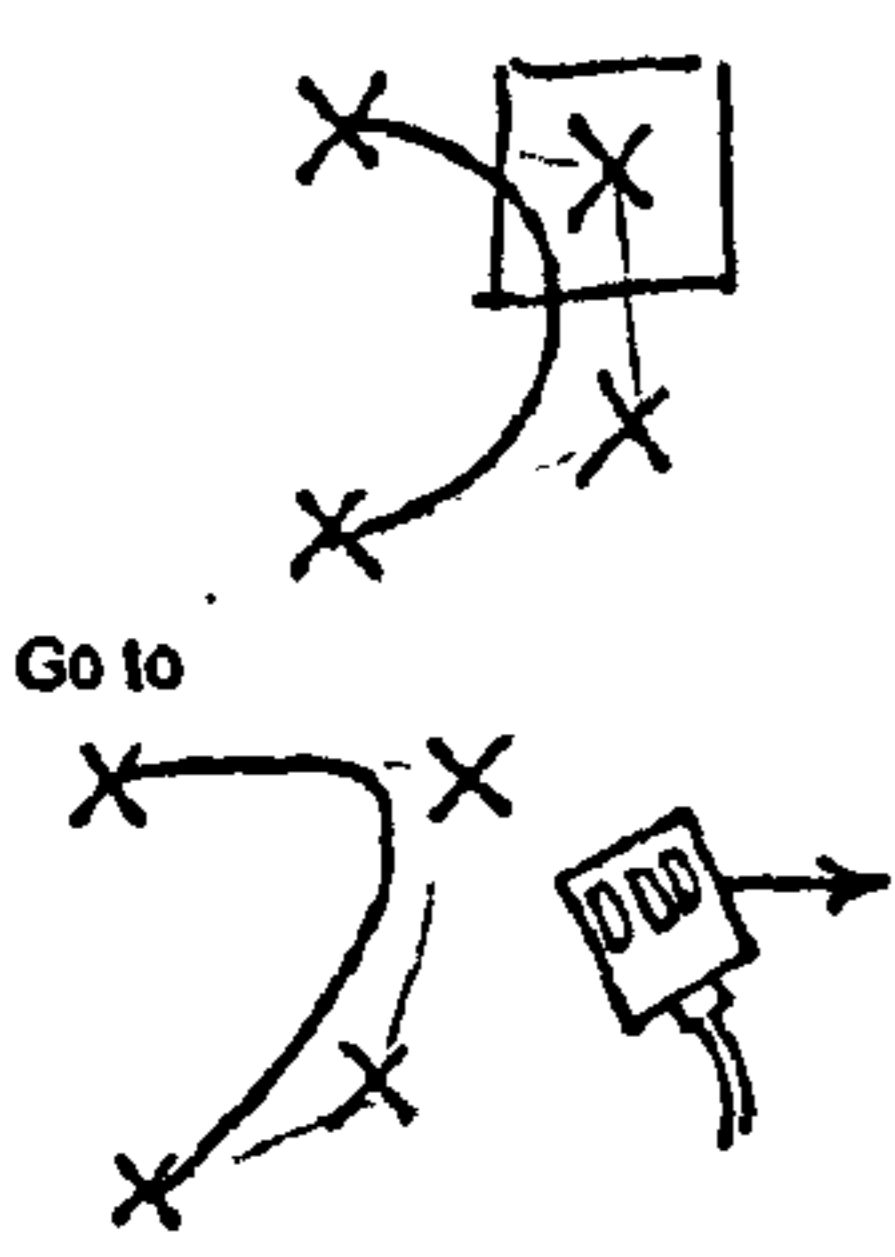
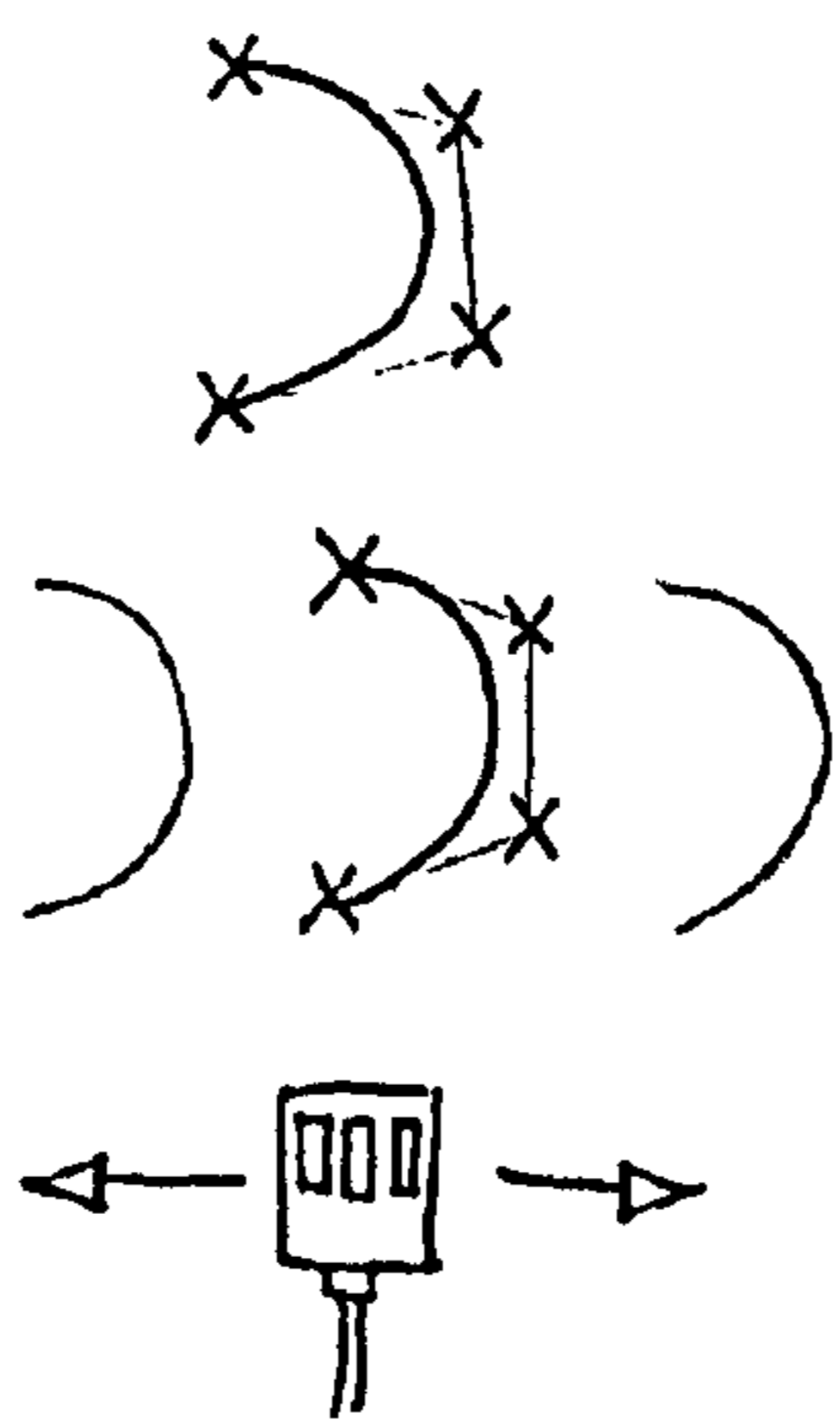
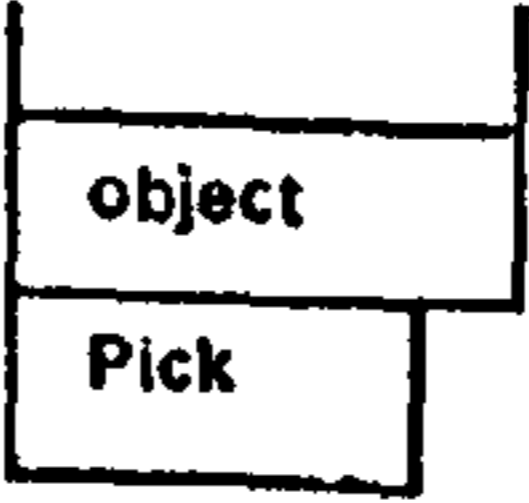
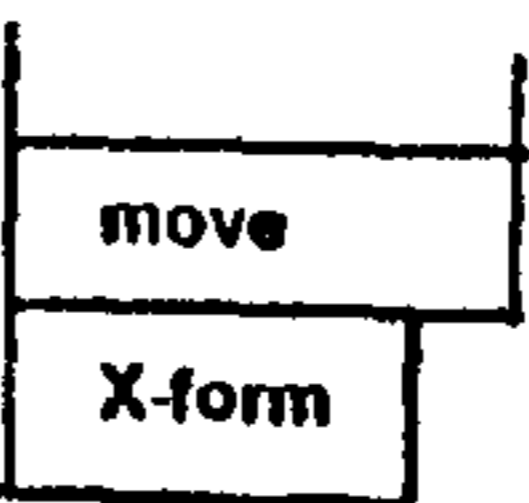
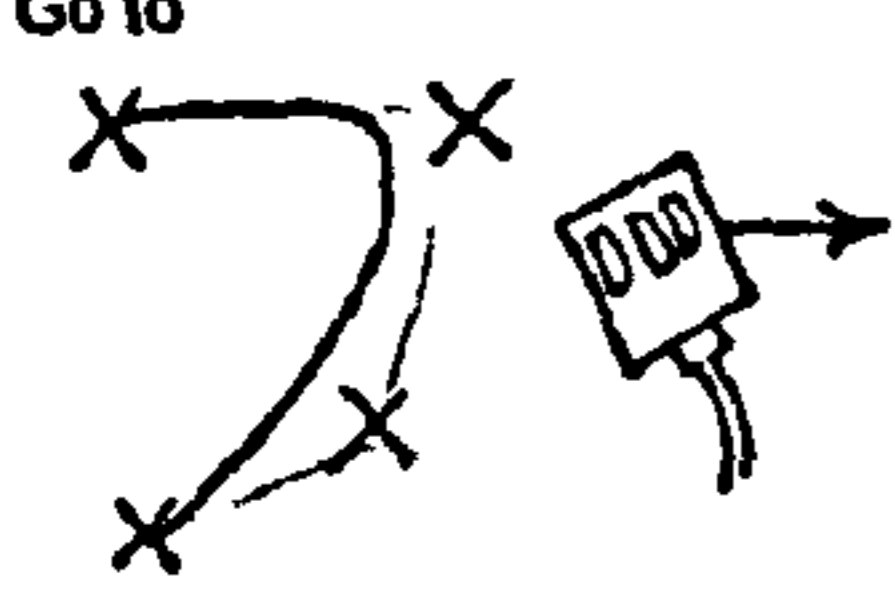
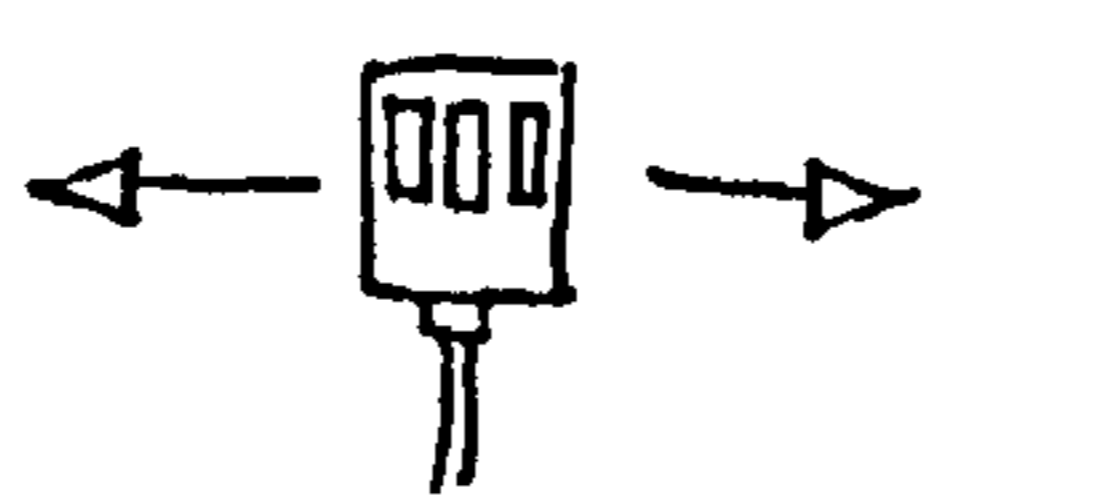
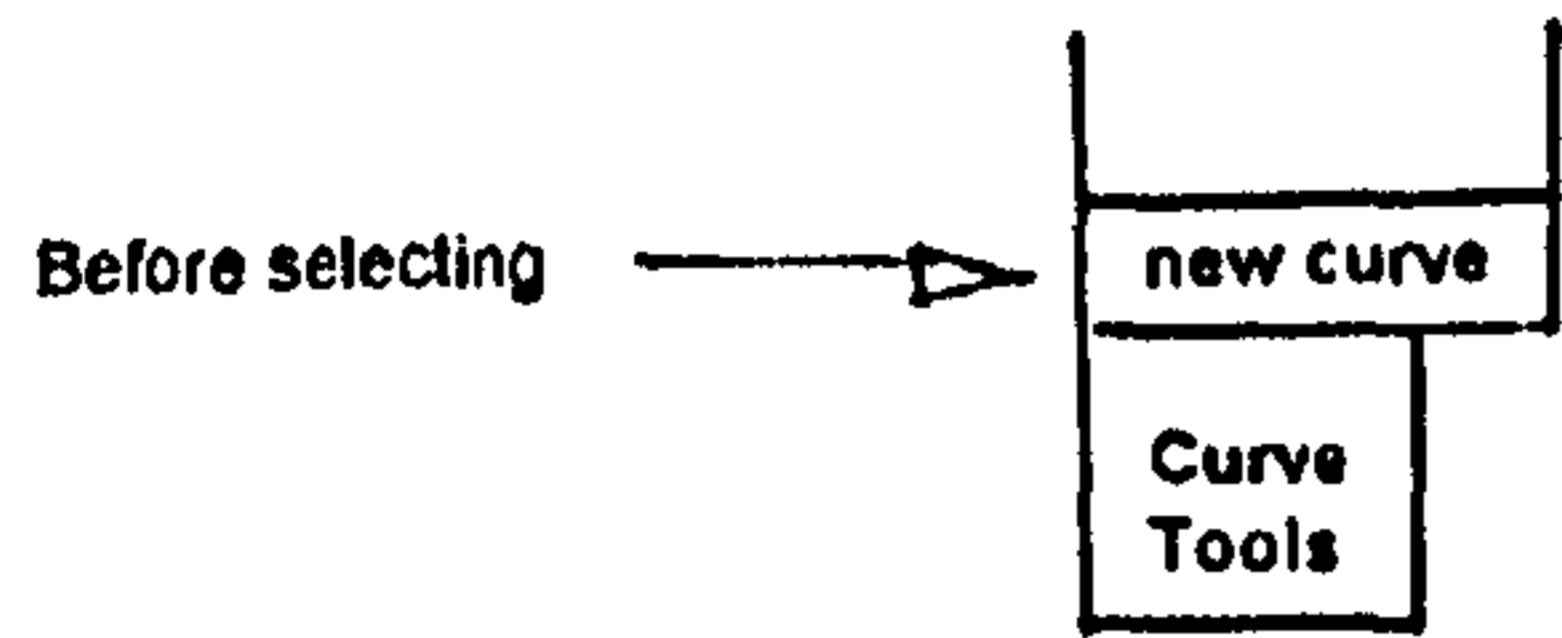
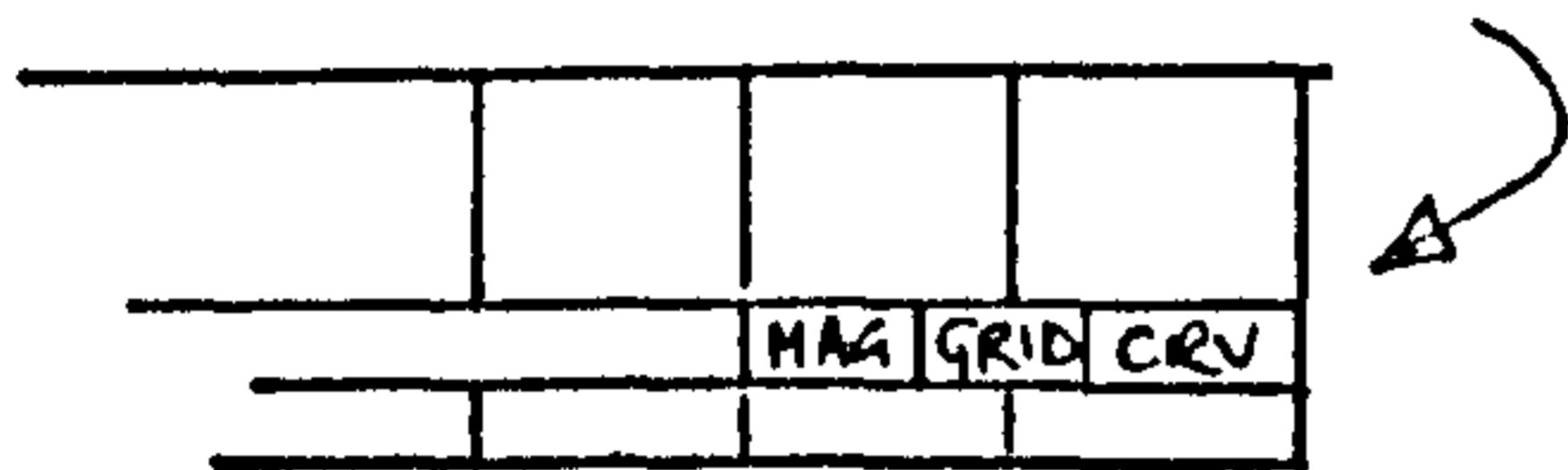

When you lay down the cv's now they will snap to the nearest grid point to the cursor when the mouse is clicked

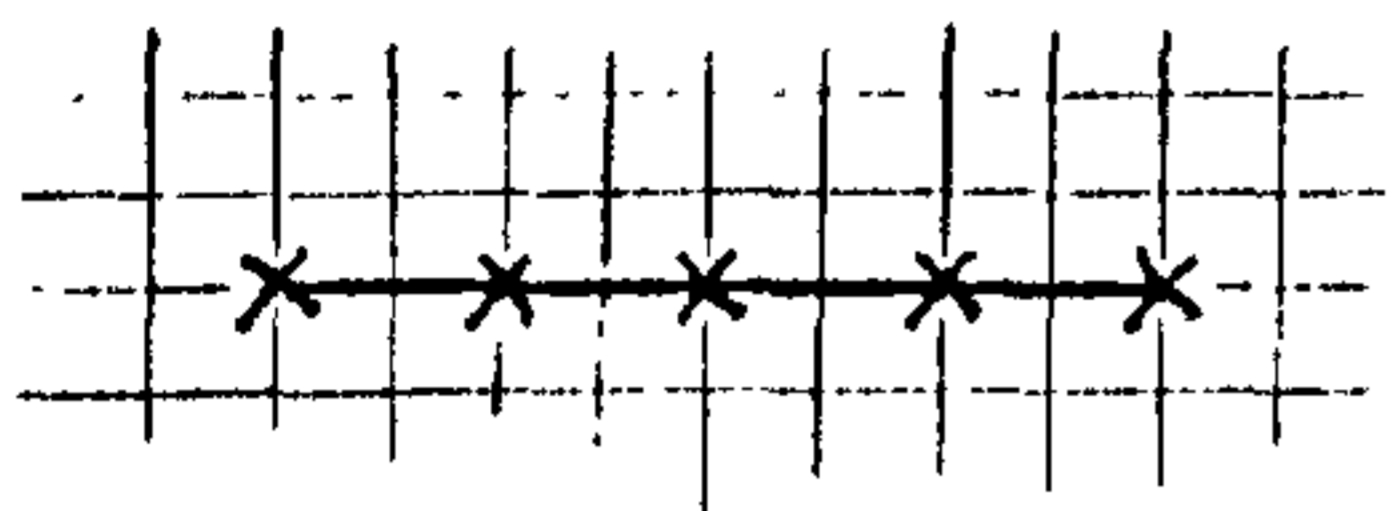

Drawing a curve is the starting point for all models

The grid can be toggled on and off whilst the curve is under construction, if for example you want the start and end cv's on grid points but none of the others, or you can use it to combine straight lines with curved

ie:

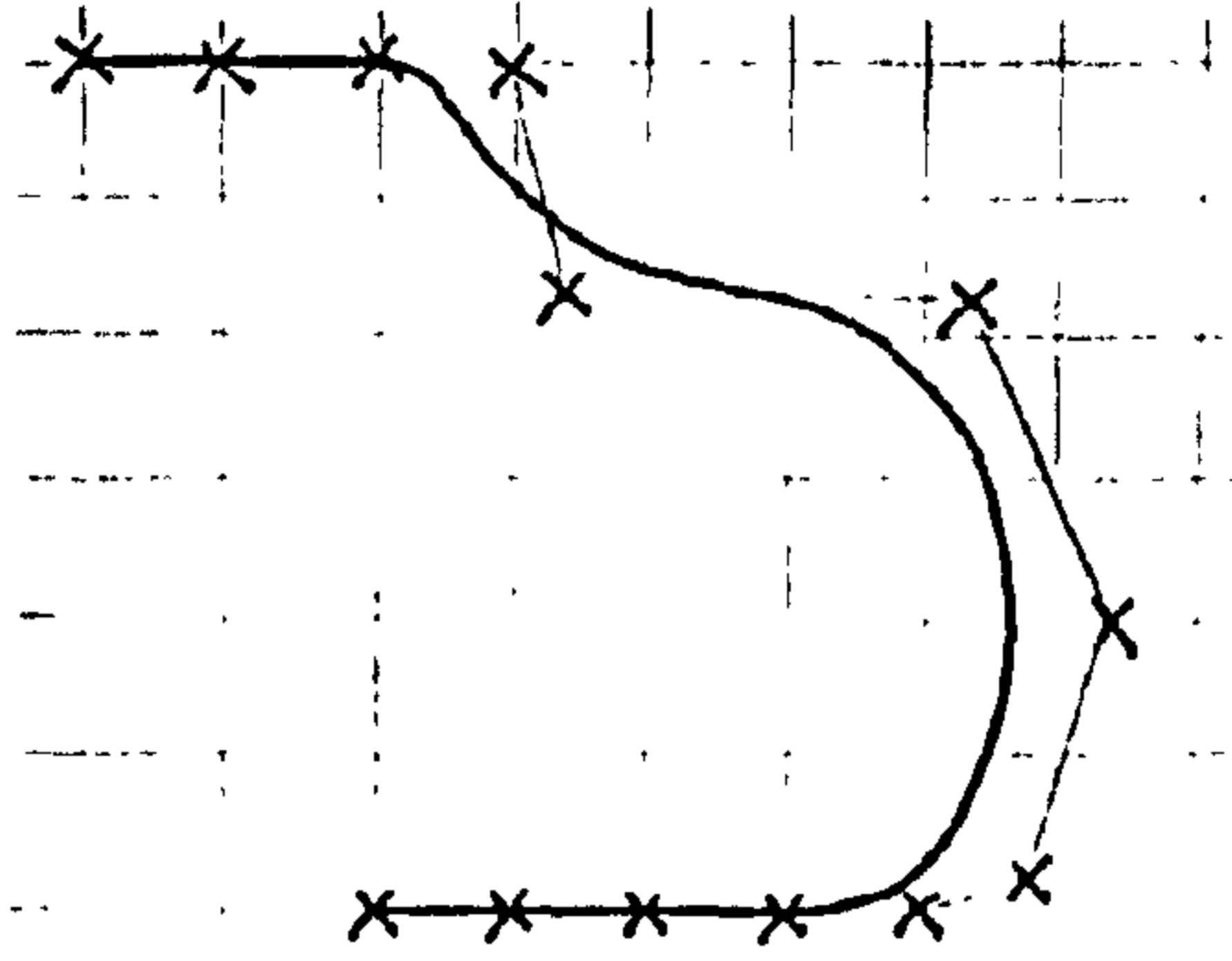
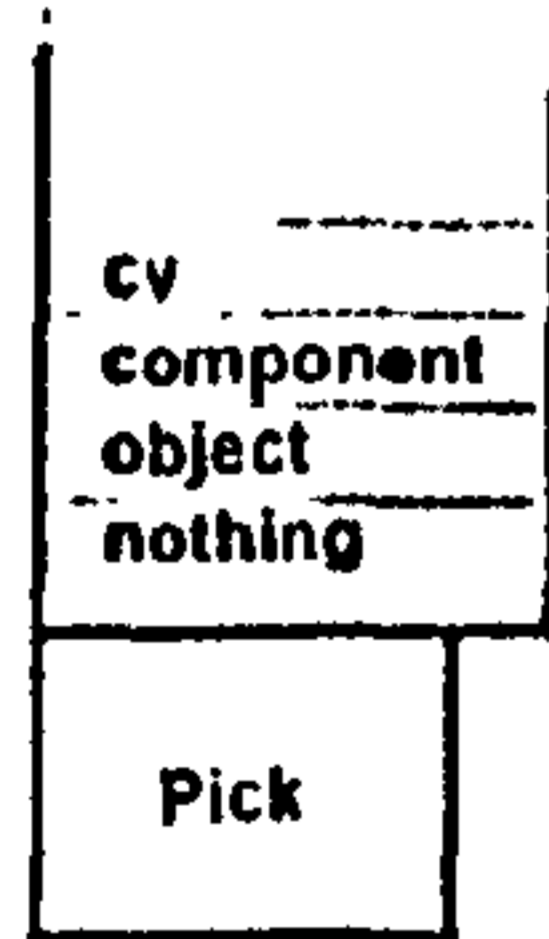

Fig. 14. Illustrating that curves and lines are a combined entity

PICKING

Once a curve has been drawn it can be manipulated in a number of ways to achieve the desired profile

The pick command is used to select individual cv's or objects in order to manipulate them, an object cannot be manipulated unless it has been selected



Once you have laid down the desired number of cv's for your curve, or finished manipulating your curve go to pick - nothing. This deactivates any cv's/objects and confirms the curve in preparation for another command

To pick a cv - click on the cv or drag a box over it

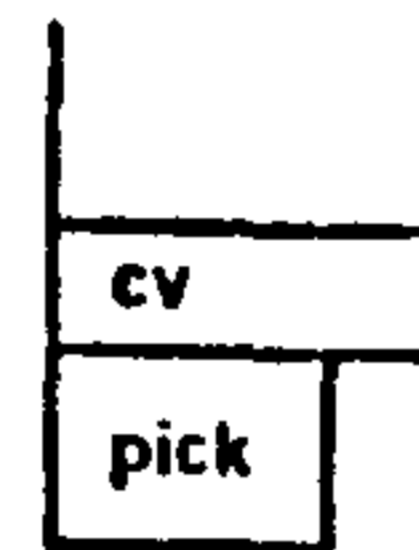

To pick an object - click anywhere on the object or drag a box over any part of it

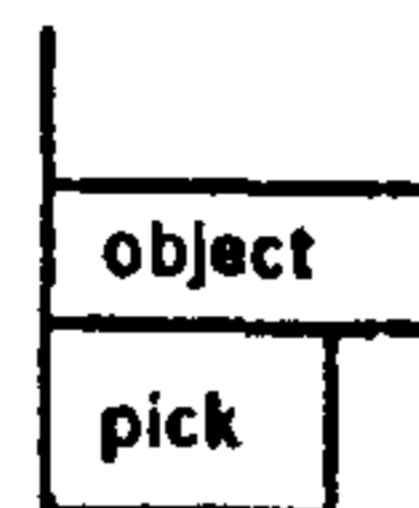

Picking on an active object deactivates it

Active objects - White
Inactive objects - Blue

Active cv's - Yellow
Inactive cv's - Red

To confirm

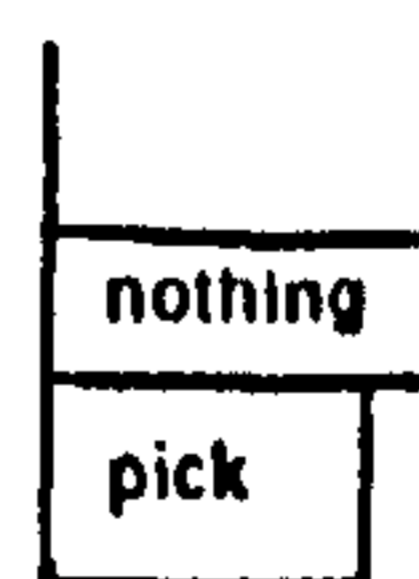

Fig. 15. Making curves and lines active and inactive

ROTATING AN OBJECT

The object will rotate around the green pivot point which will appear when the object is selected, by using the mouse (click and hold) or typing in values relative to the xyz axis on the command line

SCALING AN OBJECT

Move the cursor to bottom left to make the object smaller - Top right to make it larger, or type in absolute values on the command line.

Right mouse key will scale the object only in the vertical axis

Middle mouse key will scale the object only in the horiz. axis

Fig. 18. Rotating and scaling curves/lines

THE IMPORTANCE OF THE CURVE

Getting the original profile curve correct and understanding how that can be achieved is of critical importance within Alias.

Once this profile curve has been created you are ready to embark upon the next step - Building a Surface.

There are four basic ways of building a surface from the creation of a profile:

- Revolve the profile curve around an axis
- Patch between two profile curves
- Skin over numerous profile curves
- Extrude a profile curve along a designated path

From these basics all Alias models begin

You can also create models or parts of models using primitives. Alias has: spheres, cubes, planes, cylinders and cones - by combining, transforming or cutting these objects, you can create more complex objects.

Fig. 19. Introducing the concept that the curve/line is the starting point for most surfaces

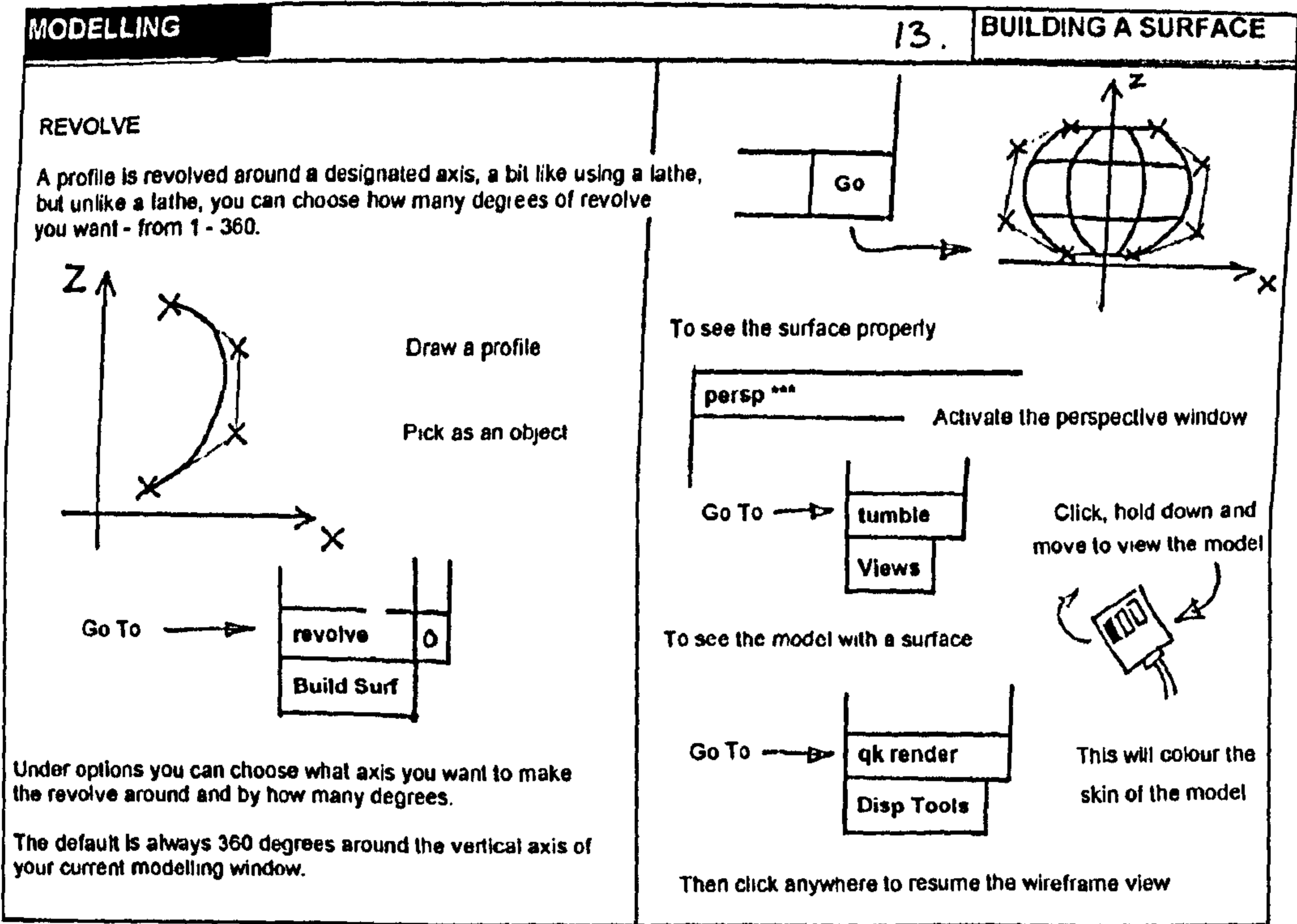

Fig. 20. Revolving the curve/line to make a surface

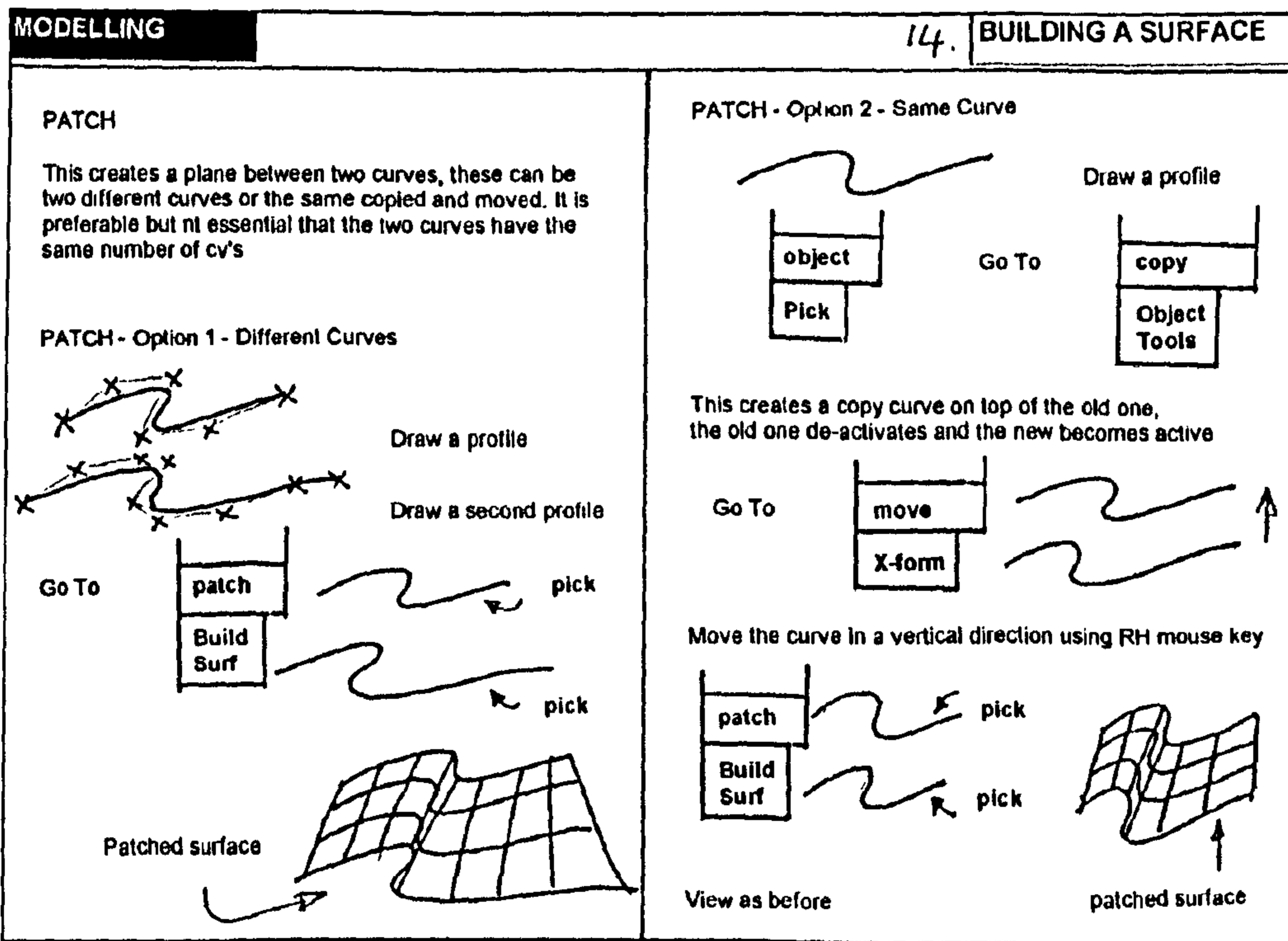

Fig. 21. Building a surface up over two curves/lines

SKIN
This is similar to patch but can use multiple profiles to create a convoluted curve

Draw a curve

Draw another two, or copy original to create three separate profiles

Go To skin
Build Surf

select each curve (in a similar place)

pick **pick**

Go

A skin is created

This surface can be viewed in the normal way

Try scaling copied profiles to achieve more complex forms

Fig. 22. Building a surface up over multiple curves/lines

EXTRUDE
This is similar to building a length of tube, where you can control both the profile and the path you wish it to follow.

Draw a profile in the front window

Draw desired path in the top window

Go To extrude
Build Surf

In top window

Select the profile

pick Go

Select the path

pick

An extruded surface is created

View using tumble in the perspective window

Fig. 23. Extruding a curve/line to make a surface

1.3 Teaching Process

The principal method underpinning the teaching process is based on reinforcing the learning of the system by teaching it to someone else. The subject for this is a Design for Industry lecturer, chosen carefully as being technologically inexperienced, but experienced in the realisation of 3D form. The process is documented in a similar way to the learning process, except that the teacher is the one documenting it, rather than the subject. The teaching process was designed to try and teach effectively, without confusing the tutee with technical details, the structure followed five stages: system awareness, pre-modelling discussions, construction, presentation, and assessment.

Reasonable progress had been made using as a teaching project a small hand held camera. Due to demands on time however, it was decided that this was too complex to be completed, and following many delays, the project was eventually suspended. However, despite these problems, some interesting findings were made. As an experienced industrial designer, the tutee had no problems understanding the geometry he was seeking to create. However due to his inexperience with computers, the majority of problems were procedure based, remembering where things are and the hierarchy of commands.

1.3.1 Teaching Process Worksheets

This section contains a few examples of the worksheets employed as part of the teaching process. The objective of the teaching process was to reinforce the learning process by teaching the software to another member of staff.

Alias - Teaching Process - Progress Worksheets

Date: 28/5/93 Time Started 10:15 Time Finished 12:45
 Project: CAMERA

Reference Information: ACTUAL PRODUCT.

Start Point: CLGAN STREET / AWARENESS DONE.

Goal for the Session: LENS COVER / POSS BUTTON(S)

End Point:

Progress Notes

With small prompts remembered most of entry procedure - most problem with right at start remembering when things to check as to access programme. With encouragement from me remembered how to set up windows + draw a curve. Started by going through drawing a curve and manipulating it. recap + revision session. through key refs.

Session Conclusions / student / teacher comment

Did OK today - kept forgetting procedural things but I know that these will come in time. Need to get the index cards sorted out, in order so that I can learn him to work things out for himself as this is vital in order to learn.

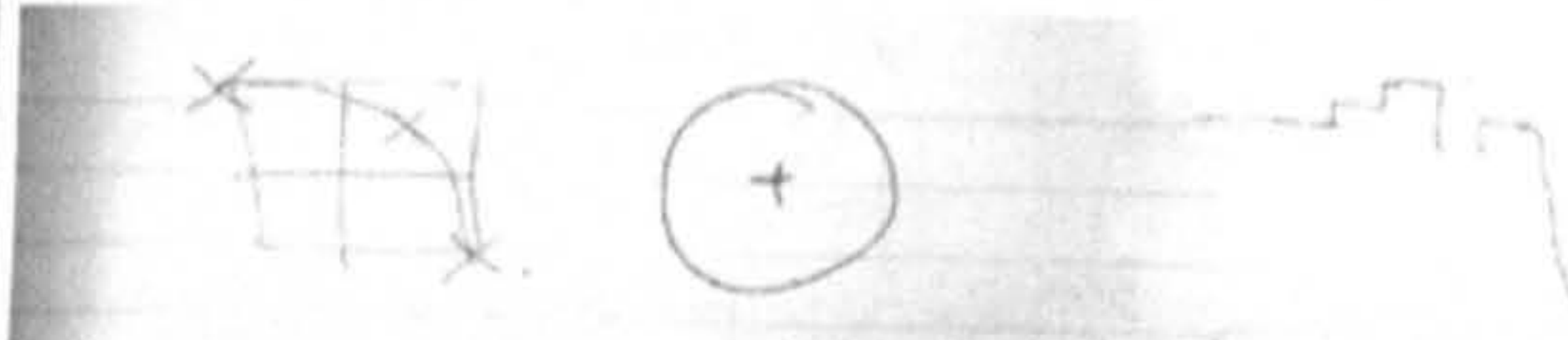

captured, moved point + scaled to achieve inner wall.



moved points to correct position then attached for full profile



Now need to revolve to create full lens housing - deleted profile.

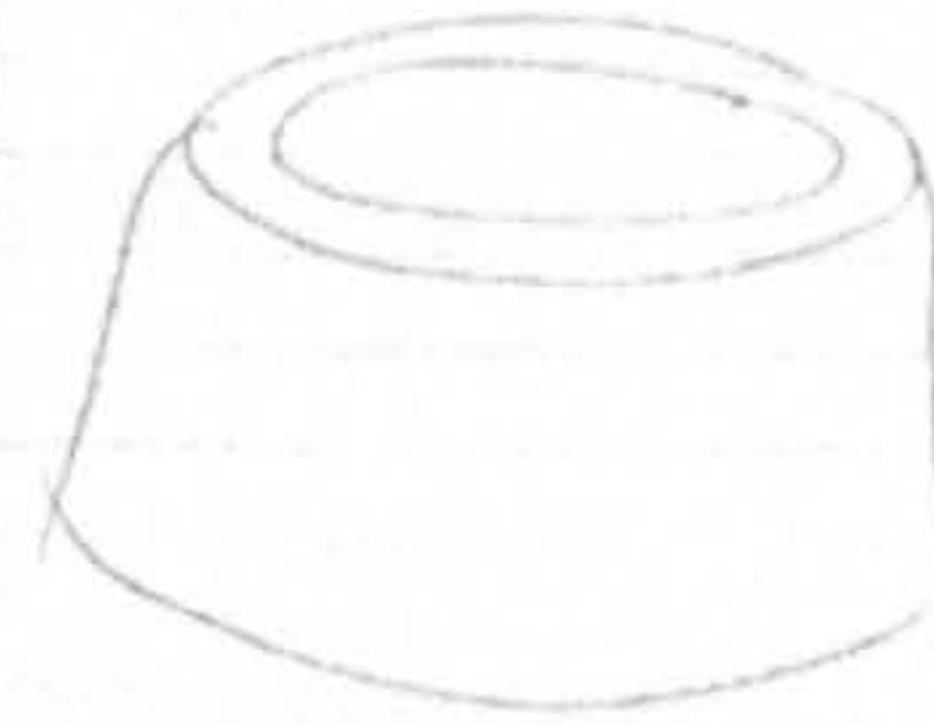

housing created went to render to set colour + finish.



Set colour to black, phong and moved lights till happy with rendered image.

lens cover

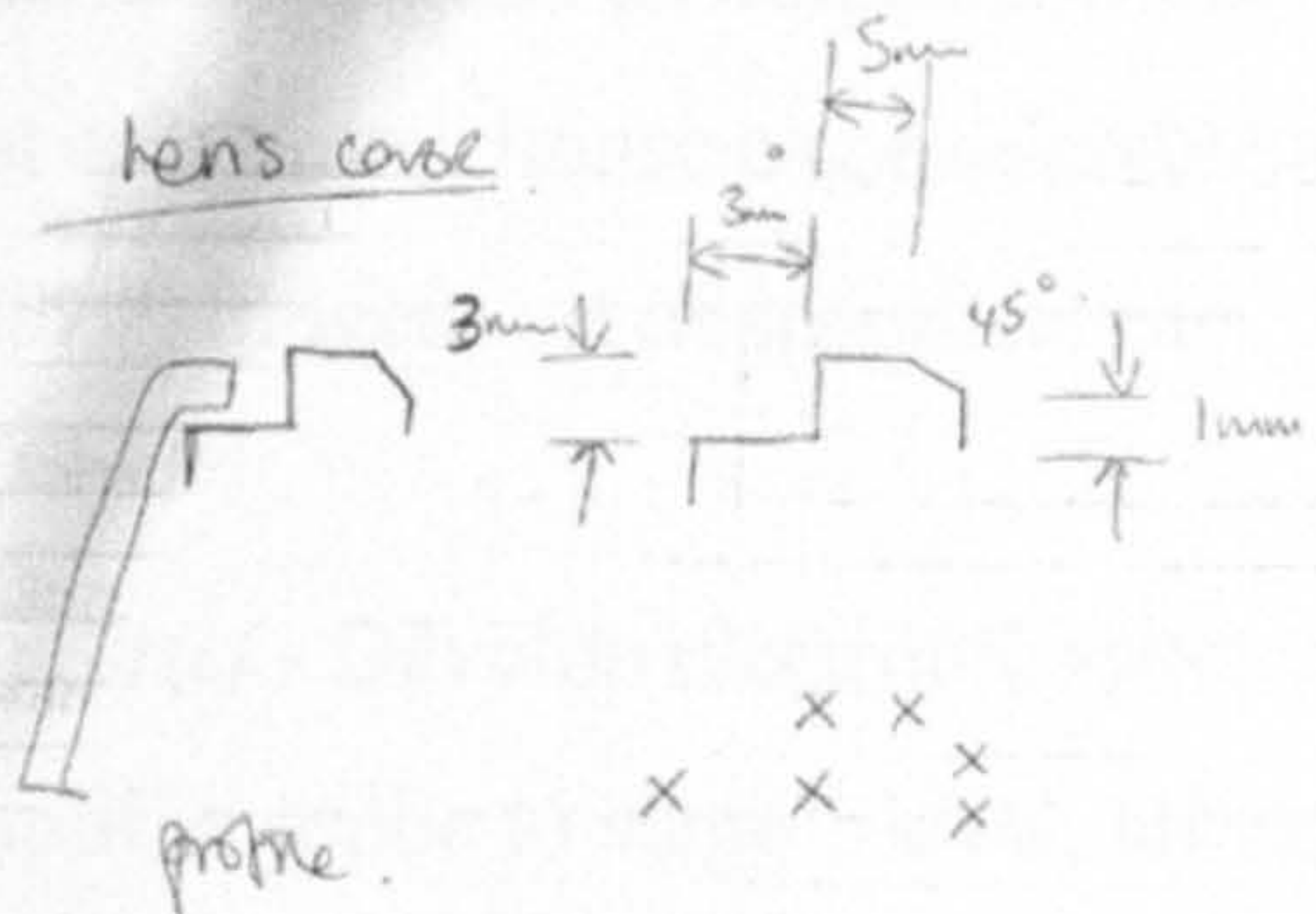

changed multiplicity and reduced to get profile. Managed this OK without help. Had not deleted original profile - this will take some time to get into head!!

Shutter

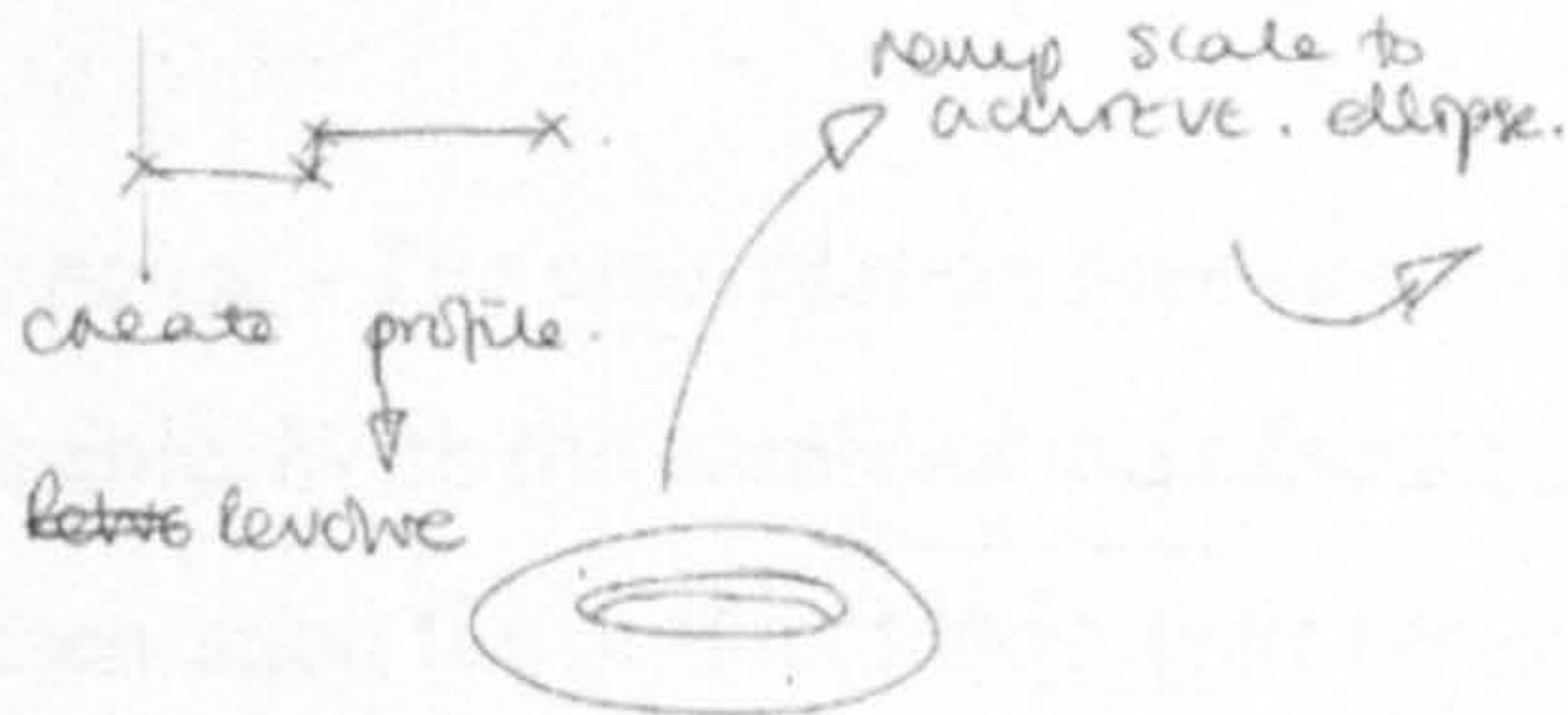

onto multiplicity. Also went through snap to grid + went thru map.

Start with lens housing. (set grid). Draw profile. Measure housing.

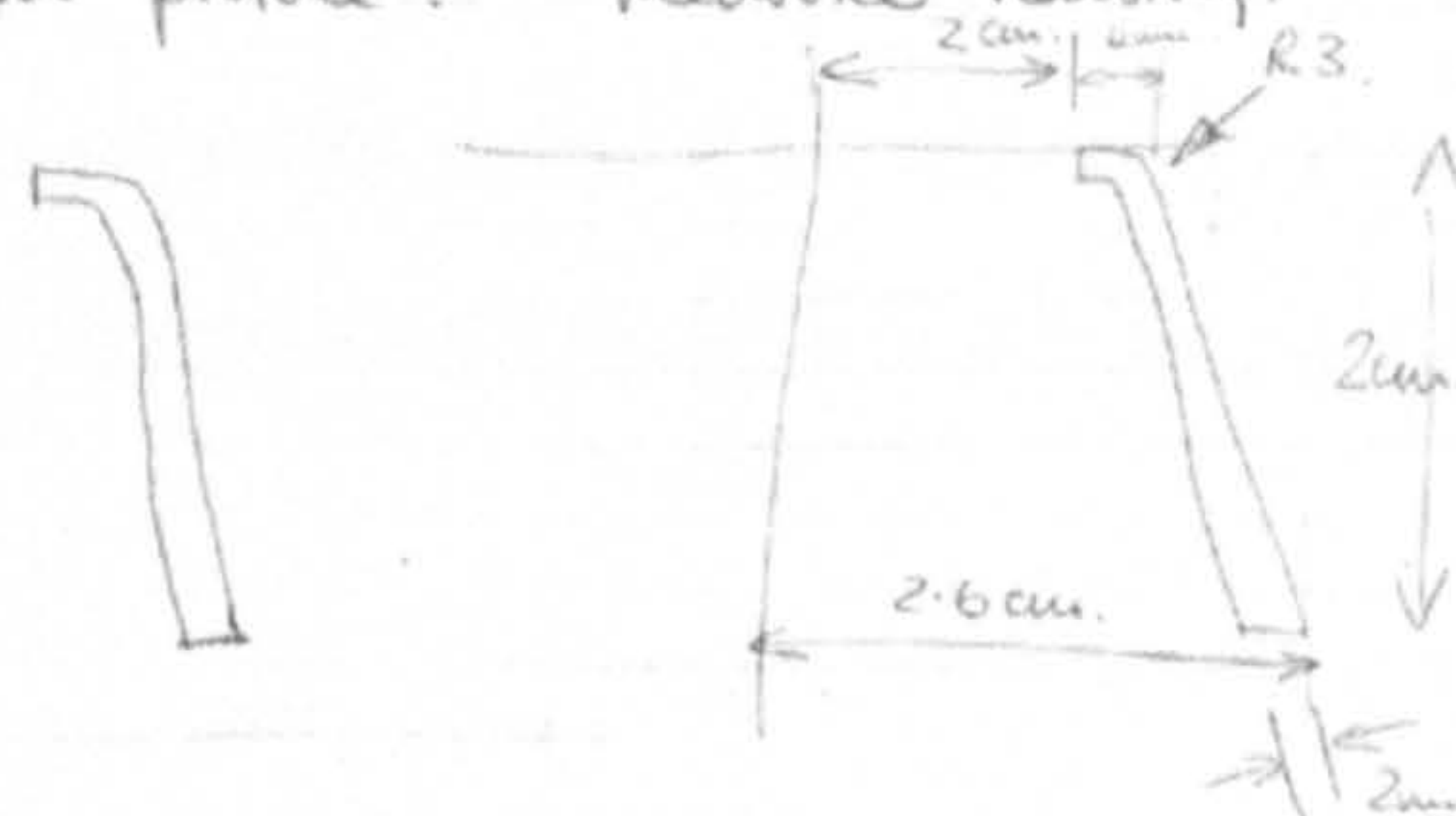

need 3 to define radius.

Had to draw to create correct curve.

too little.

experiment with mapping around off grid. print + multiply.

Fig. 24. An example of a teaching process worksheet

1.4 Formative Case Studies

The principal objective of carrying out these studies was to investigate methods by which Alias can be used for the creation of virtual models as an integral part of the industrial design process. Both of the case studies were based on live projects, but compared to the later case studies¹ were much smaller in scale and complexity. These cases represent the principal evidence supporting the hypothetical statements. They both deal with the conceptual stage of a design project, one prioritising function over form, the other form over function, representing two distinctly different areas of design practice. There follows a brief overview of each case study.

1.4.1 Formative Case Study 1: Seaward Electronics



This case study covers the design, modelling and presentation of two products: an oscillator unit and an amplifier probe. Both products are used within cable trace and test operations, house a considerable amount of electronics, and have to be compliant with a stringent set of specifications.

The Brief - Develop electronic schematics and design the casings for an oscillator and amplifier probe to stage 1 level, taking into consideration all technical components and their associated specification.

Requirements - The end result must be sufficiently rationalised and of high enough quality that the products can be put out to tender for an impending BT contract.

Response - The presentation medium had to be as indicative of the final product as possible. With the combination of technical content and required sophistication of presentation the project lends itself directly to the combined use of Alias and Pro-Engineer, with final form presentation visuals created on Alias.

¹ A full review of the later case studies can be found in Chapter 4 of the thesis

Despite having different components and functions, the products required the same design approach and so were designed concurrently. Following familiarisation with the electronics and associated specifications, internal schematics and external visuals were presented to the client in 2D and soft model forms. To ensure consistency the casing internals were then developed on Pro-Engineer concurrently with external casings being created on Alias. Components drawn up on Pro-Eng were transferred to Alias before being dropped into the surface models.

The Alias models were created using basic block sizes for reference, neither required particularly advanced tools for construction, although the Probe, with its complex nose shape did present a greater challenge than the oscillator 'box'. Both products were continually verified using quick render, geometry problems were sorted out principally on paper. The probe benefited from the use of soft models to verify both form and ergonomics.

In this instance where no real effects of transparency and or reflectivity were required we discovered that presenting in the form of a high quality quick render saved time, presented fewer logistical problems, and was sufficient as a communication medium. Both products were presented as orthographic and perspective views. It was decided that the products should be presented as simply as possible.

This form of presentation worked extremely well, utilising quick render cut down the presentation time dramatically, and allowed for modifications to be made during the presentation itself. This made the whole process quicker and more interactive. The level of communication was high. The orthographic views satisfied any queries as to aspect ratio and component placement. The perspective visuals presented a more dynamic view well suited to pre-selling the product in a marketing context.



1.4.2 Formative Case Study 2: Thwaites Breweries

This case study covers the design, modelling and subsequent presentation of proposals for two counter mount concepts; these are primarily point of sale products with little functional constraint.

The Brief - Design a range of counter mounts taking into consideration brewery history, the nature of the family of products, current and potential markets.

Requirements - Represent the concepts at a level where they can be presented to the board of directors

Response - To make a prototype for this type of product would be prohibitively expensive. The presentation therefore had to be of such clarity that it represented both the mount and associated graphics as near to reality as possible. This project required the use of context, representation of materials such as brass and acrylic, and the visualisation of graphics; this made it suitable for the photo-realistic rendering qualities of Alias.

Initial analysis by sketching evolved into the production of a number of soft models, determining product direction. The mounts were then modelled on Alias, and the graphic panels introduced, also modelled on Alias. A typical environment was photographed, and wrapped to the inside of a cube. Representative of a room, this ensured the correct types of reflections would be seen in the model and set the context for the scene. The Alias models were generated utilising both soft models and elevations. Both products were continually verified using quick render but needed little modification due to the integrity of the initial soft models. The graphics required continual modification as multiple developments took place.

The facilities for photo-realistic rendering were critical to the final presentation. If an object made of materials such as brass and acrylic is placed in a white room, it would have no character, the dynamics of the environment are required to bring the materials to life. In order to successfully present the counter mounts, it was necessary to display them in an appropriate environment. Each brand and concept was presented individually, as well as brands being grouped for comparison.

This was an extremely successful project. An enormous amount was achieved concerning the manipulation of environments and graphics. From the clients point of view the medium represented the concept as near as possible to the finished product without it actually being made. Showing individual as well as combined views facilitated the assessment of each concept before comparing to others. Decision-making on future developments was rapid and informed.

Appendix 2: Case Studies & Analysis

2.0 CASE STUDIES & CASE STUDY ANALYSIS

2.1 Media types



The following figure illustrates the classifications employed during the analysis of the case study documentation. The letters and numbers within the brackets illustrate how the different media types are represented within the case study index. A full description of the different media types, including illustrations can be found on the CD.

Digital		Non-Digital	
2-Dimensions	3-Dimensions	2-Dimensions	3-Dimensions
		Sketch & Draw (SD)	
Pres. Illustration. (PI)		Pres. Illustration. (PI)	
Tech. Drawing #1. (TD#1)		Tech. Drawing #1. (TD#1)	
Tech. Drawing #2. (TD#2)			
	Model#1: sketch. (M#1)		Model #1: sketch. (M#1)
	Model #2: unconstrained. (M#2)		
	Model #3 constrained. (M#3)		
	Model #4: Appearance. (M#4)		Model #2: appearance. (M#2)
	Model #5: prototype. (M#5)		Model #3: prototype. (M#3)
	Computer Visualisation. (CV)		
	Computer Visualisation- Animation (CVA)		

Fig. 25. Table illustrating the breakdown of, and abbreviations for, media types used in the case study analysis

Design Process	Importance	Year	Month	Date	Activity	Source	Media Type
Pre-Design Discussions	1	1993	May	19	CID send speculative letter to JJML	DE3	
	3			25	JJML confirm 1st meet date & send conf. agree.	DE3	
	4		June	3	Initial meet with JJML at Centre	DE1.	SD
	4		July	12	Quotation & project plan sent to JJML	DE1	
	1			19	JJML query ownership of IP	DE1	
	1			20	Confirmation that IP owned by JJML	DE1	
Concept Generation Stage Start	5			21	Brainstorm session	CD	SD
	1			23	Research evaluation carried out & questions sent to JJML	DE2	
	4			28	Received part answers to research evaluation & original design brief received by CfID	DE1	
	3		Aug	3	Further answers to research evaluation received	DE3	
	0			3	Audus Noble sign confidentiality agreement with CID	DE7	
	0			6	LMG sign confidentiality agreement with CID	DE7	
	0			18	Consultancy contract sent by UBS to JJML	DE1	
	5			20	Interim Presentation (initial concepts)	DE2. CD	SD. Pl. M#2. CV.

Fig. 26. Bi-Liquid Mixing System: Case Study Index

2.2.2 Project Summary

This document provides a summary or overview of the events that occurred during the execution of the project. The project was carried out between May 19th 1993 and August 24th 1995.

The Brief

The brief was to design a method of packaging two liquids, which when combined, provided a sterilising solution for endoscopes. The liquids had to be kept separate until the solution was ready to be used and the user must have no access to the liquids until they were mixed. The container had to be tamper evident and the mixed solution had to be able to be poured in less than 20 seconds without undue splashing.

The Result

The final product (Fig. 27) consisted of six components; an inner flask made up of two components screwed together, into which acid would be poured, then capped off. This would be inserted into the neck of the main bottle, previously filled with a buffering solution, and be held there. An over cap would then be screwed on; this cap would trip over a set of ratchets on the top of the acid flask. When the over cap was screwed off the ratchets would be activated, the bottom of the acid flask would be held in the neck of the bottle and the flask would unscrew itself, dumping its contents into the solution

below. By the time the user got the cap off, the acid would be neutralised and they could pour the resulting solution out through the annular space between the flask and the neck of the bottle. To the user this extremely complex set of events would not be apparent, as far as they were concerned, all they had to do would be to screw the cap off and pour the solution out, a standard activity requiring no instruction or training.

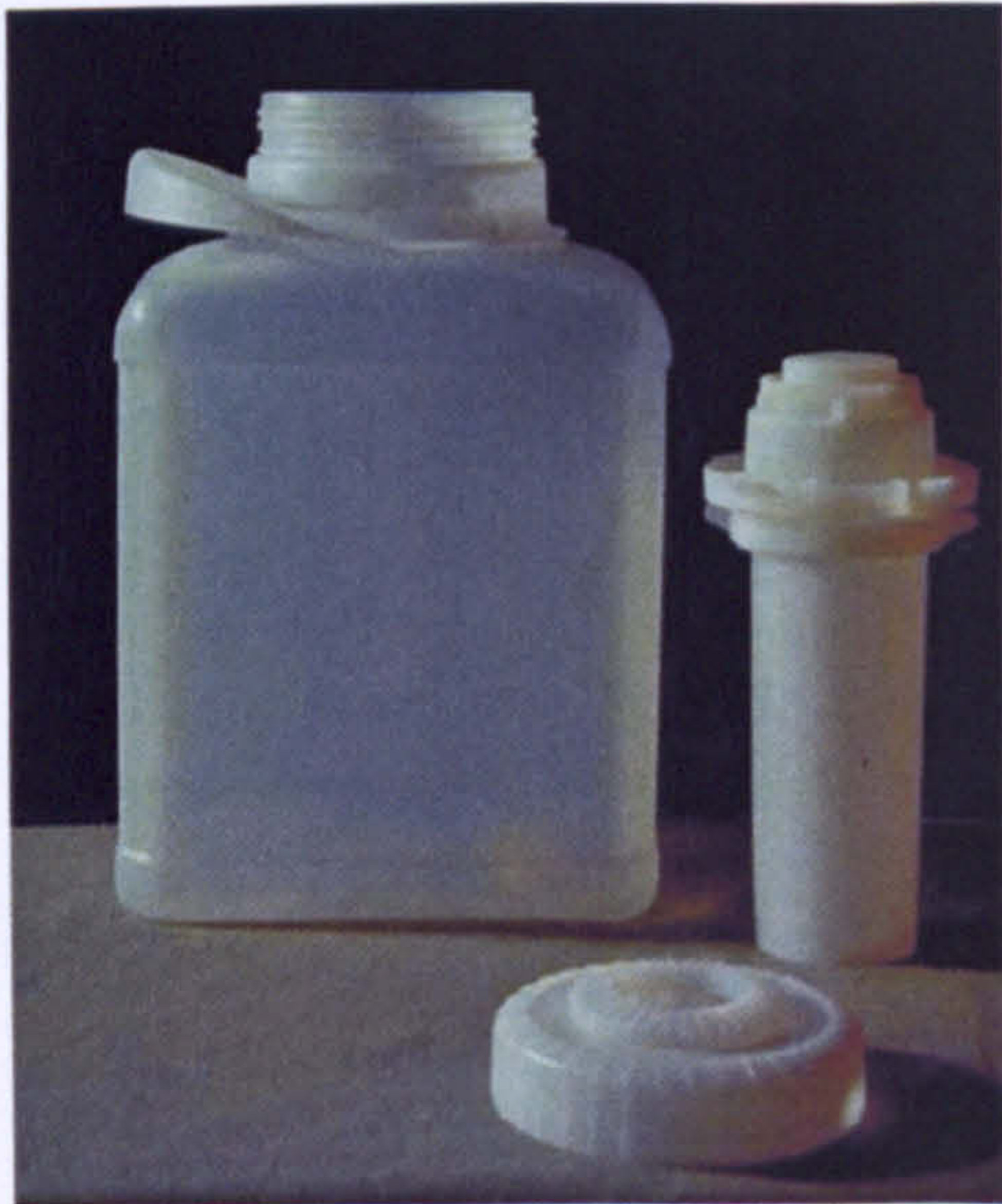

Fig. 27. Final mouldings for Bi-Liquid Mixing System

The scope of the project was ‘full spectrum’ with our responsibility to take ideas from basic concepts right through to final production and testing.

2.2.2.1. Pre-Design Stage

Following a briefing meeting with the client and an internal team discussion on June 3rd 1993 it was determined that if we were to win the project, extensive use of 3D digital modelling was very likely to be required in order that both ourselves and our clients could understand the true nature of the potential designs. As a professional, commercially oriented centre, we were keen to impress our clients with the decision making power we believed to be inherent within 3D digital modelling, until this point in time however, we had been unable to truly put it to the test. The immense scope of this project was to provide us with the potential to do just that, although at that stage we were not sure as to the extent it might play in the development of the design process. Our intention to exploit the potential of 3D modelling can be seen clearly in

our initial project proposal of July 12th 1993 (DE1). The project eventually went live on July 21st 1993.

2.2.2.2. Concept Generation Stage

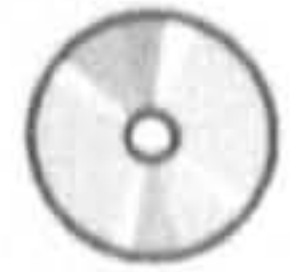

Brainstorm

Although the use of 3D digital modelling was high in our consciousness as potentially providing the main tools for the development of the mixing system, the project commenced in a traditional manner with a group brainstorming session. This was the means by which the CfID design team commenced most projects, the sketches and words drawn during them providing invaluable triggers to potential concepts when returning to review them later in the project.

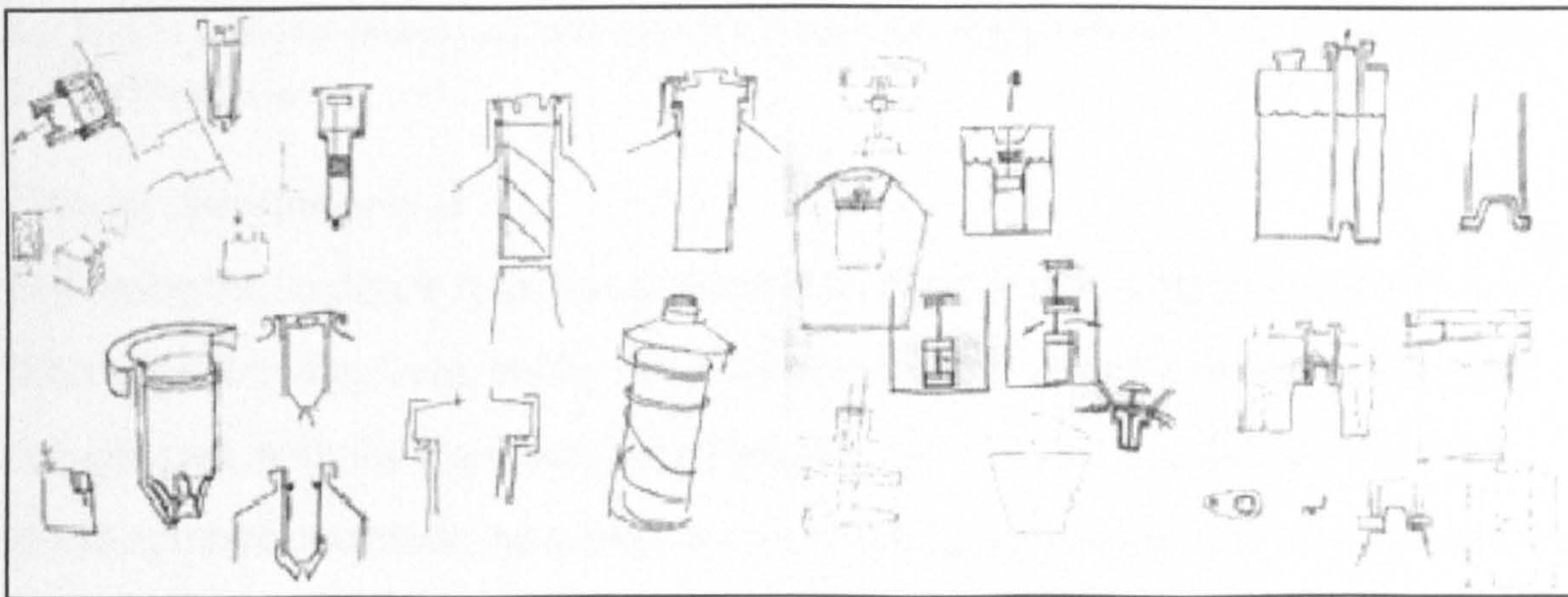

Fig. 28. Sketches from the brainstorming session

Initial Concepts

In addition to concepts, the brainstorming session threw up a series of challenges and questions about the brief, once the answers to these were provided we were able to develop the ideas generated during the brainstorming session into a series of initial concepts based around the principle of a twin aperture container. The initial concepts were generated and presented using three main methods. Concepts were generated in sketch and drawing form and presented on a series of boards (Fig. 29) along with our analysis of the project requirements at that stage. We also presented these concepts by means of 3D digital non-specific schematic models (Fig. 29). The intention of these was to give the client confidence in our ability not only to understand the problems

presented by the project, but also to impress them with the power of 3D computing. Due to the relative simplicity of the concepts at this stage in hindsight the 3D models were probably an unnecessary addition to the presentation, as they showed nothing that had not already been communicated via the 2D boards.

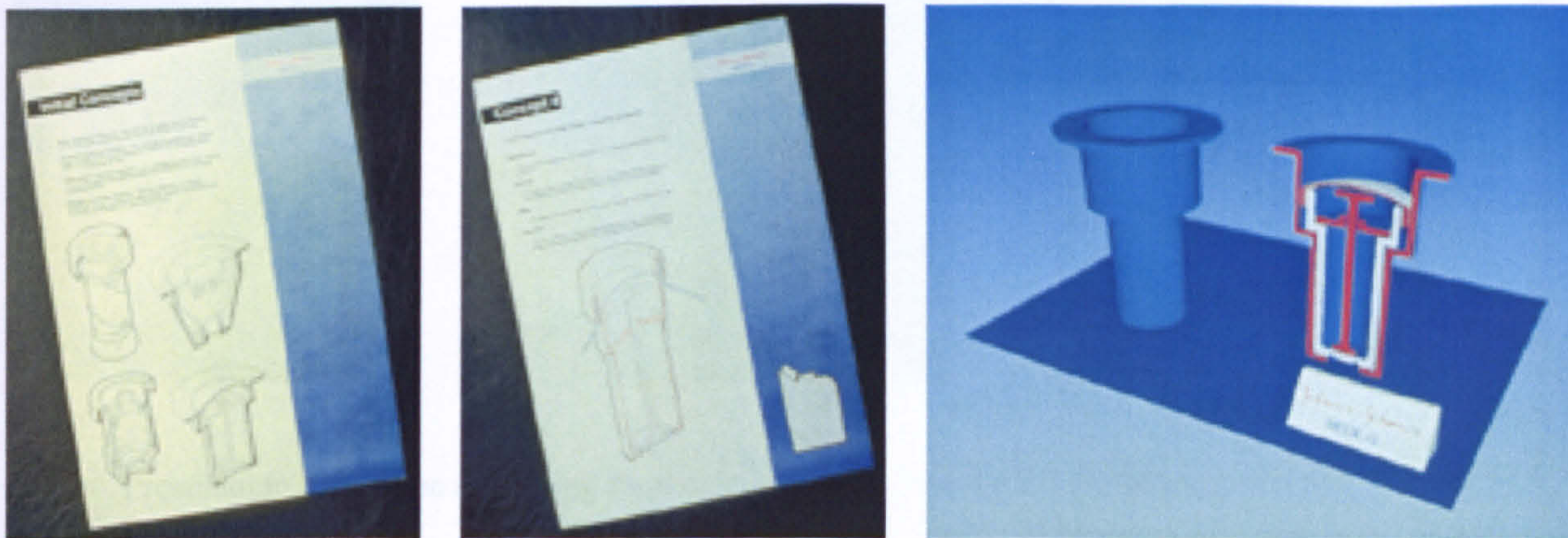

Fig. 29. Left & Middle: Boards from Initial Concept Presentation. Right: Computer Visualisation from Initial Concept Presentation

Concept Development A

Following the feedback from this presentation the concepts were further developed in sketch and drawing form, but by this time the concepts were becoming much more complicated, with the main conceptual leap occurring in the move from a twin to a single aperture container. As a team we were having some difficulty in understanding the complexities of the concept and it was decided that we would have to fully 3D model the entire system concept in order that both we and our clients could understand what was going on. For speed and because the concept was still so unresolved we decided to do this on 'Alias'², an unconstrained surface modeller, although we knew that for tooling it would have to be created on a constrained modeller at a later date. On September 15th 1993 we presented 'Design Development A' which consisted of two main concepts. Both were presented by means of 2D drawings (Fig. 30) on boards combined with a series of 3D snapshots (Fig. 31) of the strongest concept in various stages of assembly and disassembly. This proved invaluable in order to be able to

² Alias™: see Glossary

communicate our design intent. This concept was selected and would go on to form the fundamental basis of the final product.

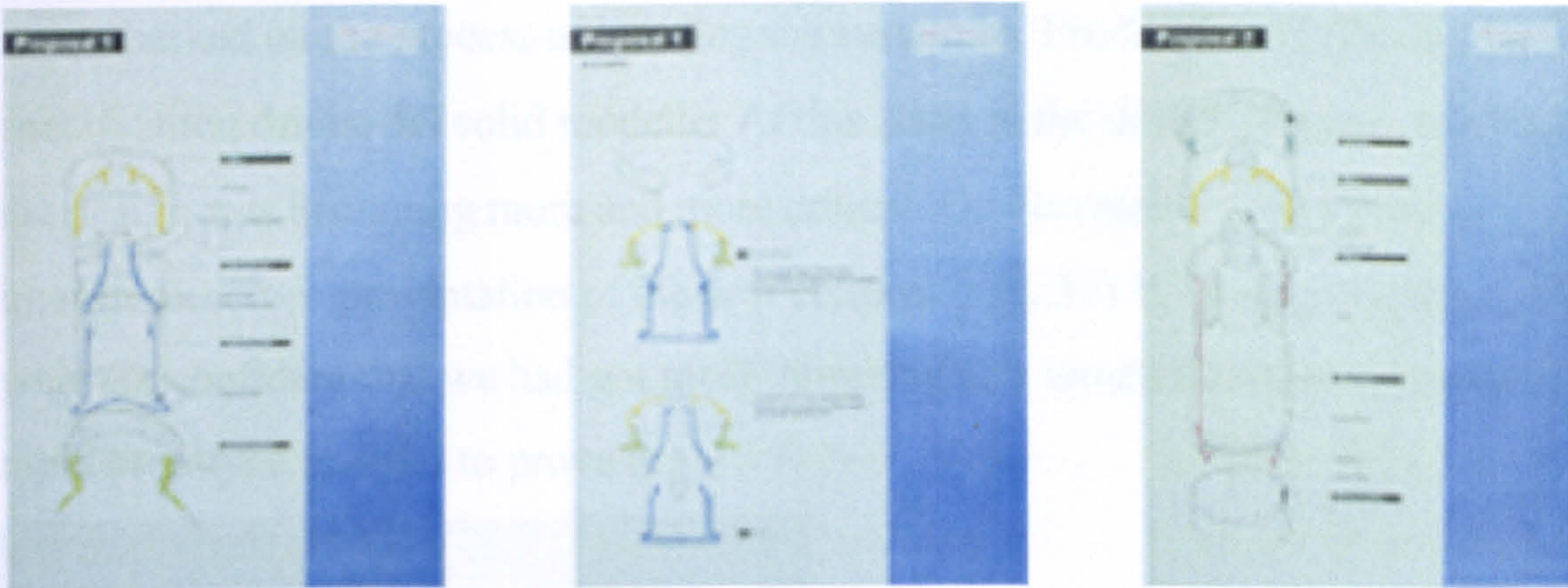

Fig. 30. Presentation Illustration explaining the two 'Design Development A' concepts



Fig. 31. Computer Visualisation showing left: the favoured concept and right: the principle of the concept

2.2.2.3. Design Development Stage

The client company was now sufficiently confident enough with the design that they shared this presentation with their board and approval was given to take the project to the next stage. With the fundamental concept upon which the design would be based now in place we were able to embark on design development. Taking the concept to a stage where we could be sure of functional and manufacturing feasibility.

Design Development B

Following the presentation of 'A' we very quickly realised that there were some fundamental problems with the concept. We used a combination of sketching, drawing



and 2D CAD to develop the concept to a point where we were able to send preliminary drawings out to toolmakers and moulders for initial quotes (Fig. 32) At the same time we embarked on the process of building the system in 'Pro/Engineer' (Pro/E)³, a specification driven 3D solid modeller At this stage in the design process, accuracy in the design was becoming more and more critical. On November 17th 1993 we had an interim on screen presentation of the new concept (Fig. 33) We suggested that whilst we were confident that we had got most things right, it would be necessary to go to a rapid prototype in order to prove it.

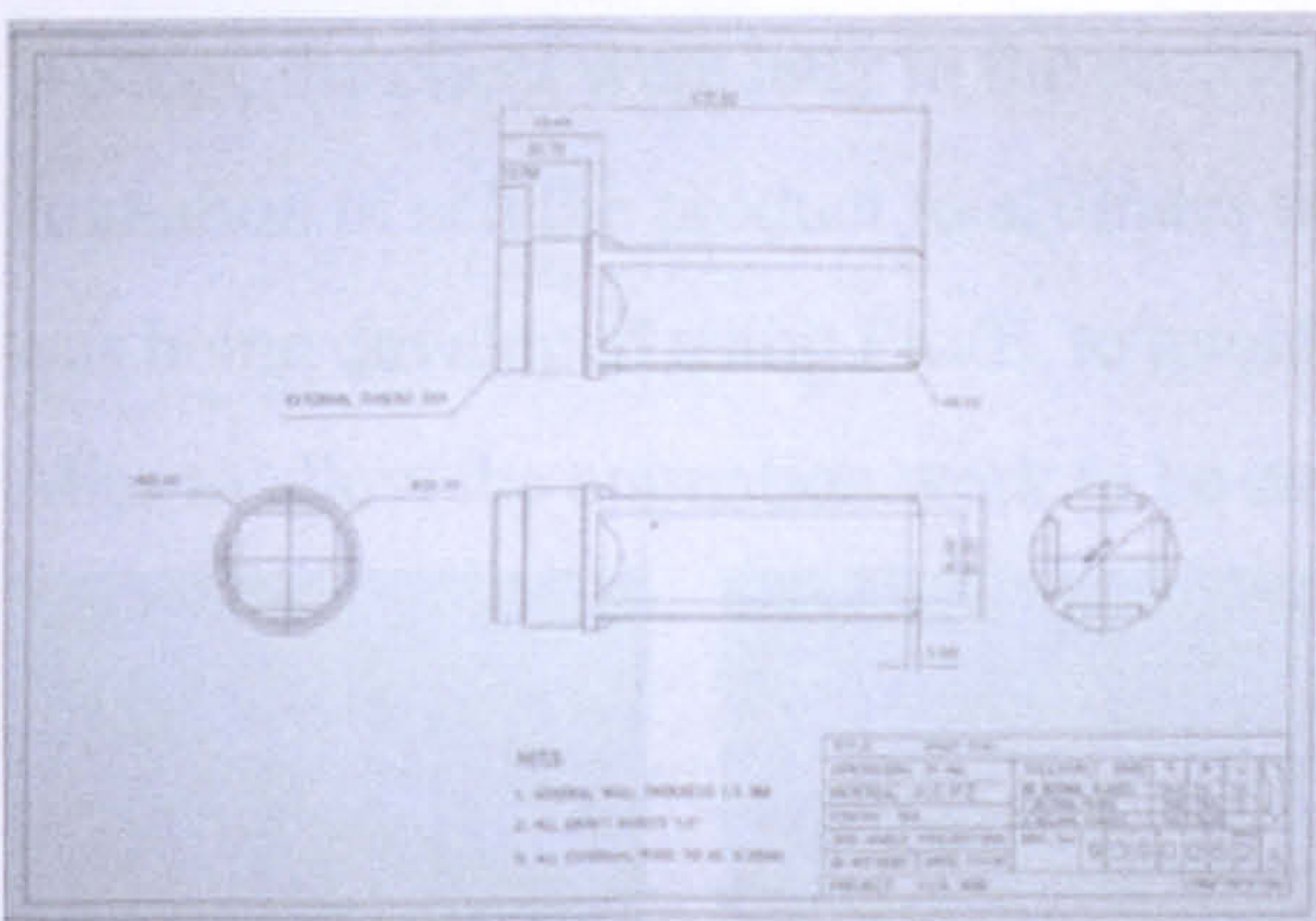

Fig. 32. Preliminary 2D drawings for toolmakers and moulders

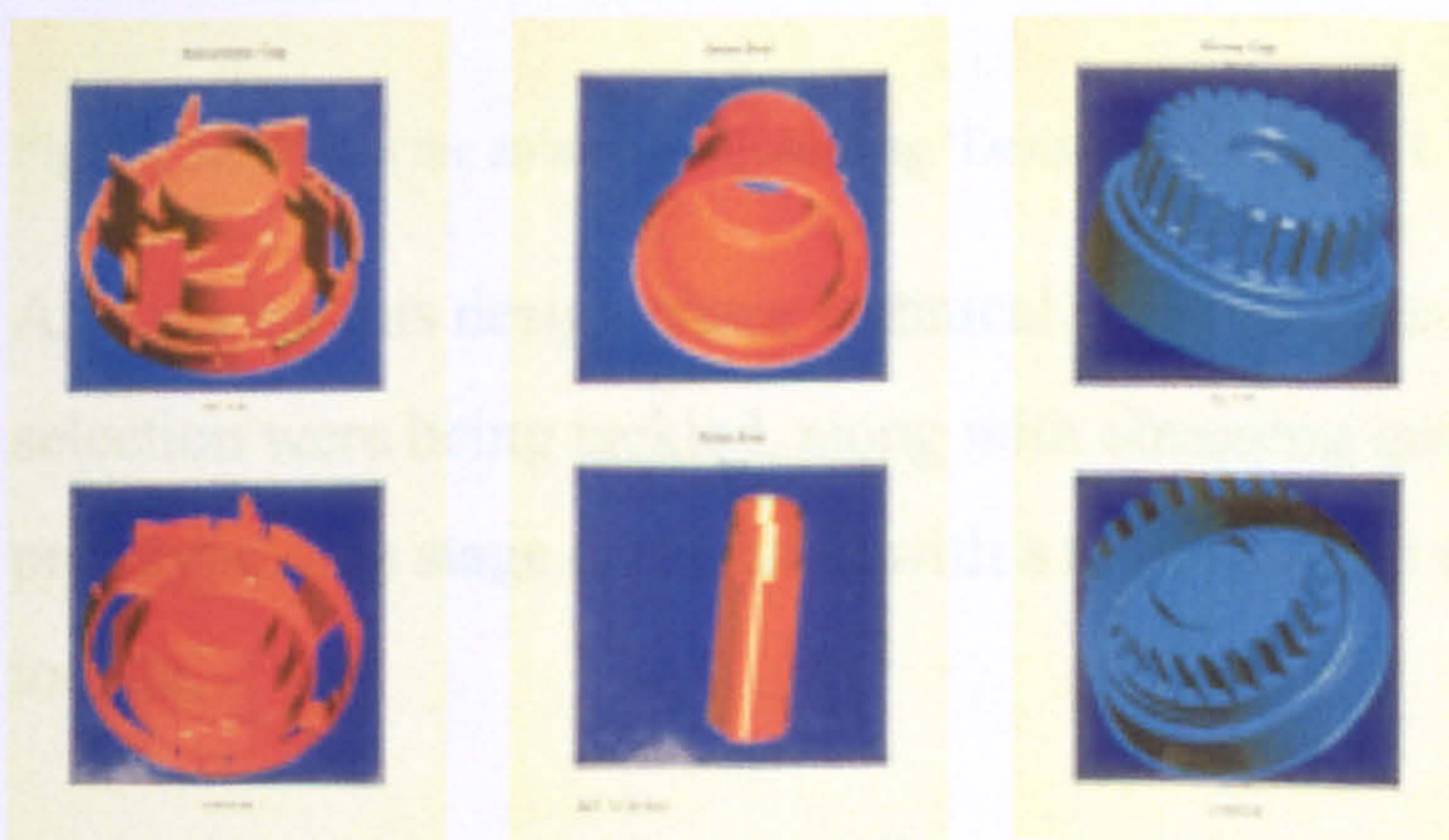

Fig. 33. Revised Concept: 'Design Development B'

Design Development C

The next month was spent further developing the design through the use of 3D solid models, by this stage in the development this was the only way in which we could

³ Pro/Engineer™: See Glossary

control the parameters of the design Sketches were used to work out small details, but the 3D model was the only way to get an overall view of the product and its functionality. However, whilst we could understand the concept via this method it was felt that our clients might have difficulty in fully understanding the changes to the concept by these means alone. To assist this understanding we created a short animation sequence (Fig. 40) which showed the assembly of the product and its subsequent disassembly at the hands of the end user (whilst the production of this animation can be seen as being over and above the general demands of the design process, the client were later in the project to commission us to do a full length animation to sell the product to affiliates at a global marketing meeting). As the design was being developed using Pro/E, to avoid remodelling, the parts were imported into Alias to allow the animation work to be carried out.

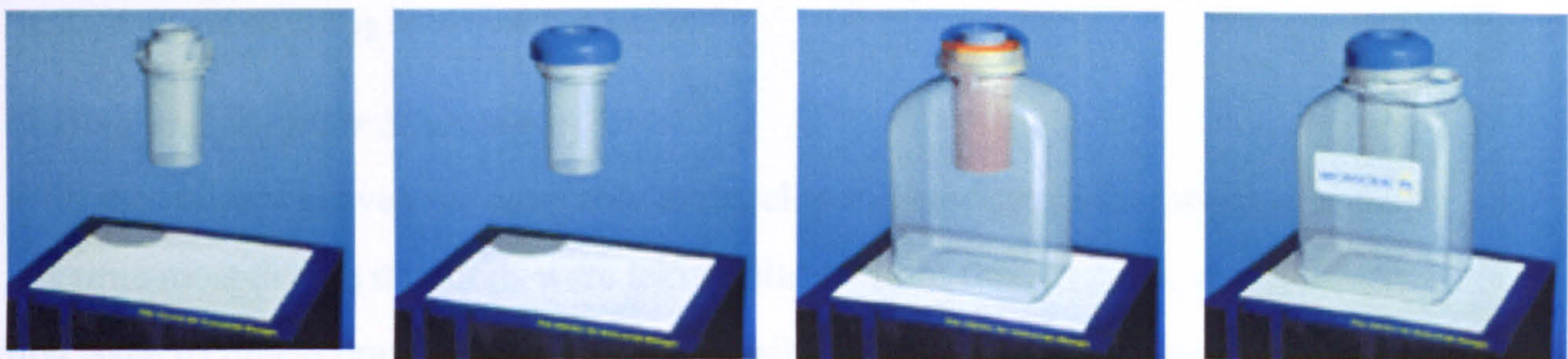

Fig. 34. Stills from the animation illustrating 'Design Development C'

Also during this design phase technical issues such as moulding and seal material selection were being tackled, along with obtaining quotes for the production of a rapid prototype. The stage culminated with a review of the design and all aspects of progress to date.

2.2.2.4. Specification Stage



1st Prototype Development

Approval having been obtained for the production of a rapid prototype⁴, an SLA⁵ model was commissioned. However, the release mechanism within the design hinged

⁴ Rapid Prototype: See Glossary

on a series of ratchets which had to flex to make the design work. SLA resin is very brittle so flexible polyurethane castings (Fig. 35) were taken from the SLA. These lost some of the original accuracy of the original rapid prototype but allowed us to prove that the concept would work.



Fig. 35. Polyurethane casting taken from SLA master.

Costing and Supplier Sourcing

With the concept proven we were able to develop the product further within Pro/E, by this time most design iterations were taking place within this medium, and produce first issue technical drawings for in depth feasibility discussion with manufacturers (Fig. 36). Representatives from the CfID and the client company spent four days visiting potential manufacturers discussing all issues concerning the functionality, manufacture, assembly and production of the product. For this we employed the polyurethane casting (Fig. 35) to explain the concept, and left the potential supplier with the drawings to enable accurate quotations to be supplied. The purpose of these visits was twofold, firstly it was to seek expert opinion on the design on the components, and secondly, to assess which manufacturers had the appropriate facilities and approach to carry out their designated part of the production process.

⁵ SLA: See Glossary

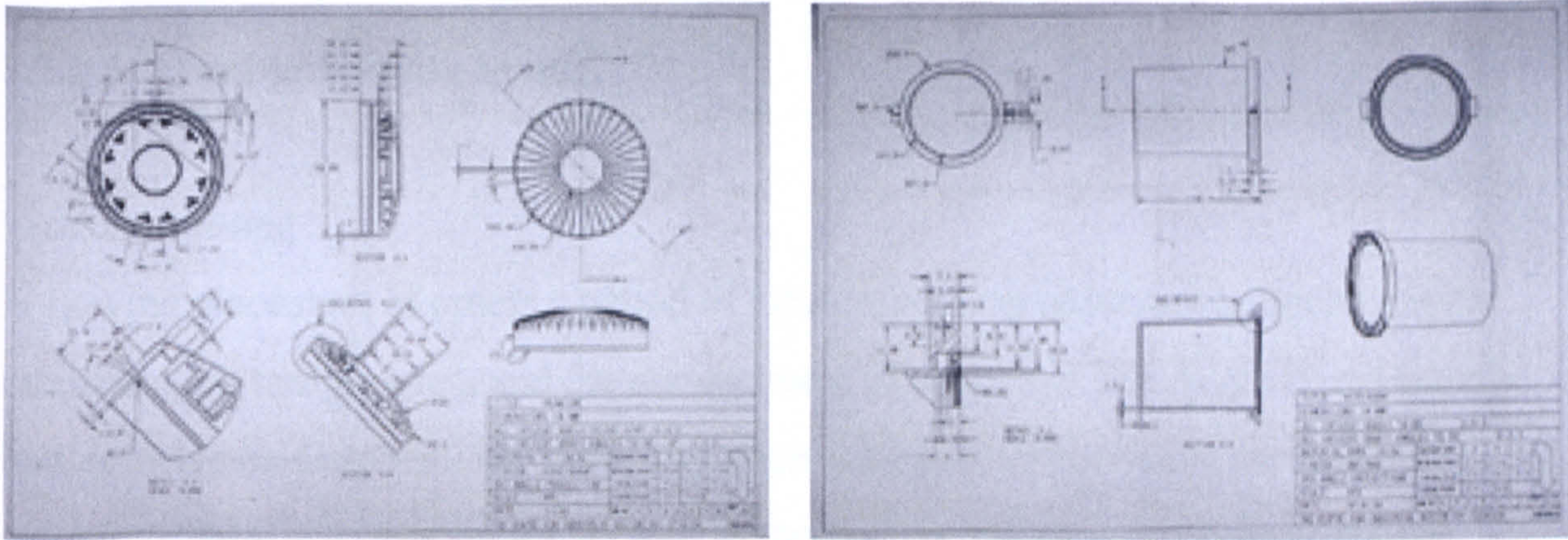

Fig. 36. First issue technical drawings: created directly from 3D modelling data

Design Refinements and Specification

Subsequent to these visits there was a period of design refinements as feedback was obtained with respect to costs and feasibility. Design work on a handle and siphon attachment was also ongoing via the use of sketches and non-specific models. On April 12th 1994 a design review was held where the design of the handle was presented (Fig. 37), general technical detail was reviewed and feedback was provided on costs and supplier recommendations.



Fig. 37. Computer Visualisation of proposed handle

Following the selection of proposed suppliers a round table meeting was held between the suppliers, the client and the CfID to consider all design and production details. Again, the rapid prototypes and drawings were the main tools used to facilitate communication between the various parties. There followed a series of numerous small amendments and modifications to the design of the various components, until on July 27th 1994, orders were placed for tooling.

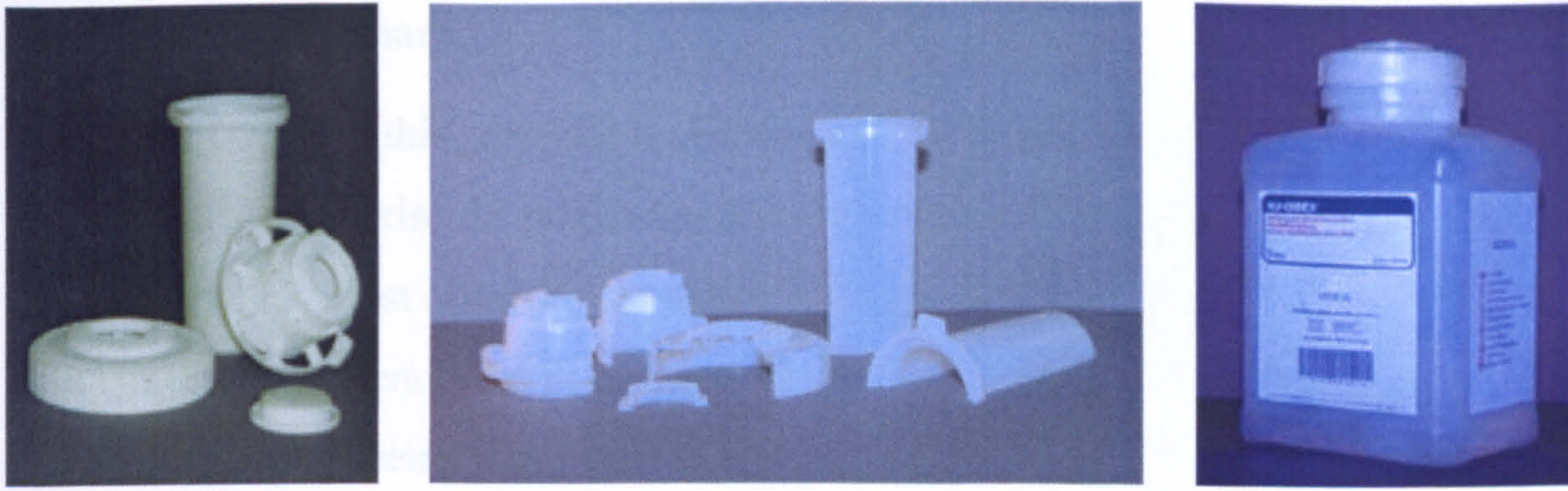

Fig. 38. Left: SLS rapid prototype parts. Middle & right: Off tool plastics.

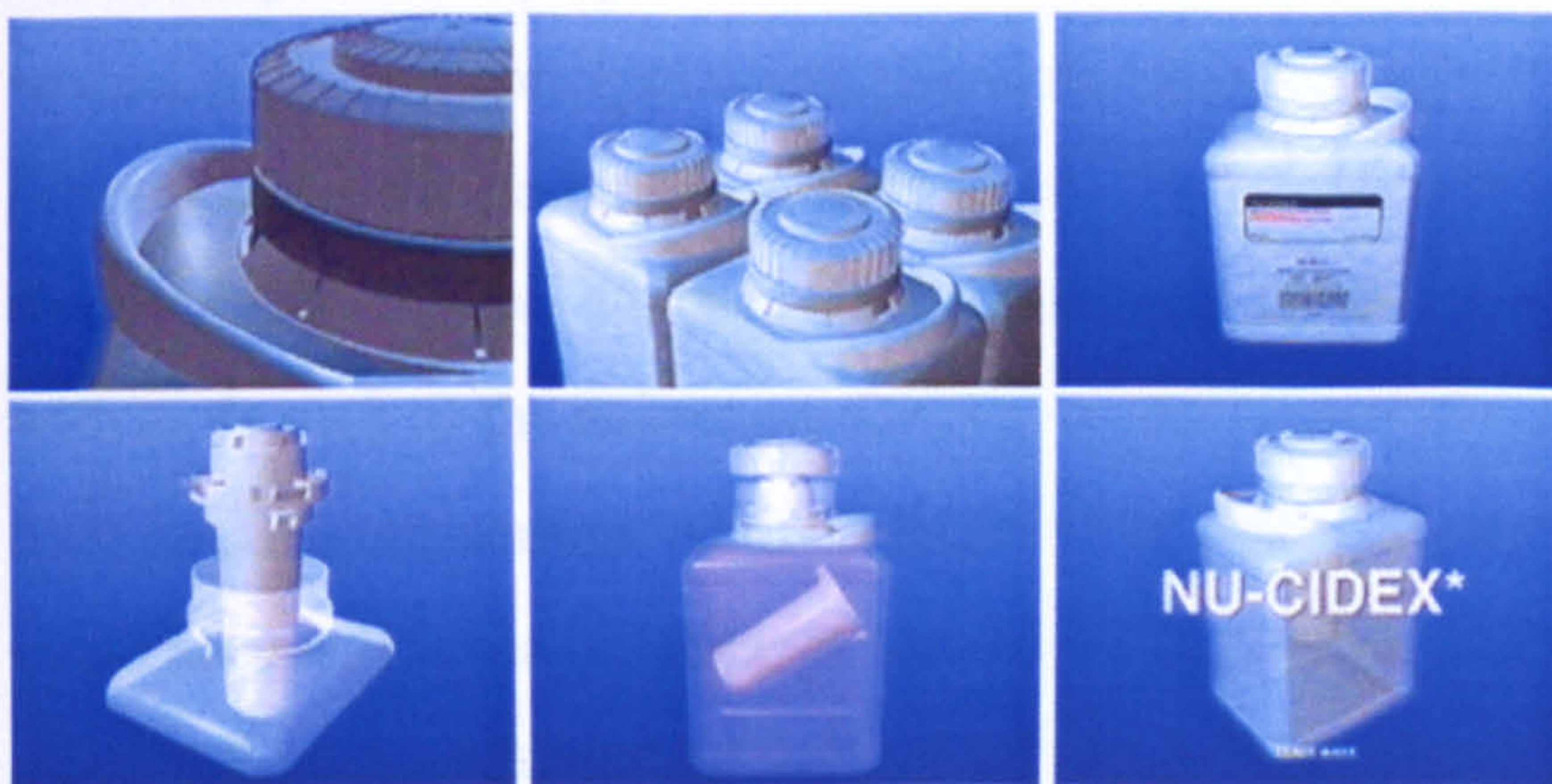

Fig. 39. Stills from animation produced for the world affiliates meeting

A further period of troubleshooting follows and on February 1st 1995 1st off samples of all parts are delivered and the product can be properly put together for the first time.

Final Details

With the principal components now in place this stage was focused on getting the handle and all tolerances resolved. With the true components available some minor tool modifications are made to improve the functionality of the product. Initial tests on the sealing and venting are carried out. A number of Failure Modes Effects Analysis (FMEA) sessions are held between the client company and CfID to ensure that the product satisfies quality and safety standards both in terms of design and production. Final modifications are made and product is submitted for final testing. On August 24th 1995 the contract is deemed complete.

2.2 Case Study 1: Bi-Liquid Mixing System

Client *Multinational Pharmaceutical*

Product: *Bi-Liquid Mixing System*

Brief: *To design a bi-liquid mixing vessel for use with a new sterilising solution*

2.2.1 Documentary Evidence

The documentary evidence is categorised as follows:

- (i) Starting the project: original briefs, quotes and schedules.
- (ii) Design reviews and general reports: including supporting research data and meeting notes relevant to design issues.
- (iii) Correspondence to/from client.
- (iv) Correspondence to/from other parties.
- (v) Supplier selection/visit documentation.
- (vi) Quotations: (i) tool making/moulding, (ii) prototyping, (iii) misc. components.
- (vii) Confidentiality agreements
- (viii) Patent related information

Appendix 1: General company information

Appendix 2: Misc. Items not dated

2.2.1.1. Index

A section of the Bi-Liquid Mixing System Case Study Index is illustrated as Fig. 26, the full index can be found on the CD.





2.2.2.5. Troubleshooting Stage

Troubleshooting

Following placement of orders a period of troubleshooting commences, including the monitoring of tool progress and the management of suppliers. The first off tool sample bottles arrive on October 27th 1994. The main troubleshooting issues are focused around material selection issues, as well as the sealing and venting of the container. Most of this communication is carried out via fax using a combination of words, sketches and diagrams.

Animation and 2nd Prototype

Around the latter part of 1994 the client requested that CfID put forward a proposal to sell the design to the client's world affiliate companies. CfID propose the production of a 3D animation and a new rapid prototype, both up to date with the current state of the design. CfID design a storyboard and script and prepare data for the new prototype. This is to be made via SLS⁶, a process that allows the components to be flexible, whilst retaining accuracy (Fig. 38). Components for the animation are imported into Alias from Pro/E and a five minute film with voice-over and soundtrack is produced (Fig. 39). On December 5th 1994, CfID deliver a fully working prototype (bottle and cap are by this time off tool components) and animation to the client (Fig. 38). On December 7th 1994, these are presented at the World Affiliates Marketing Meeting at Ascot.

⁶ SLS: See Glossary

2.2.3 Process Summary

During the course of this project it is obvious that 3D modellers (both constrained and unconstrained) comprise the predominant design tool. This is principally due to two reasons; firstly in most instances the nature of the project with its complex cause and effect interactions, demanded it; but secondly it can now be seen that there was a distinct element of seeing it as a means of impressing the client. In hindsight there are incidences of its use within the project that are in excess of the requirements of that incidence, this is particularly apparent in its use to present initial concepts. In the earlier stages of the project the use of 3D computing gave the client the confidence that we had generated concepts worth pursuing, and in the latter stages it was imperative to the proving of the design through the use of rapid prototyping. It was also extremely useful in enabling our client to communicate the design of the product independently, with tools such as the animation forming a total piece of communication, requiring little or no interpretation. At the time that this project was carried out few toolmakers could accept 3D data so although we were able to generate 2D specification data directly from the 3D models there was still a certain amount of interpretation required on the part of the toolmakers. However it is true to say that having the ability in the earlier stages to supply essentially a photograph of the finished component, and in the latter stages a physical model, removed a considerable amount of this interpretation. It is fair to say that without the use of 3D computing neither the client nor ourselves would have had the confidence to pursue the concepts to the extent we did, and if we had, it can be assumed that the amount of tooling modifications required would have been far more extensive.

The project did not utilise any of the aesthetic tools such as soft modelling or appearance models, this was primarily due to the functional nature of the project, the complexity of the components making such approaches inappropriate and unnecessary.

2.3 Case Study 2. Soulagil

Client: *Procter & Gamble (P&G)*

Product: *Soulagil*

Brief: *The re-design of a packaging solution for a throat spray that would retain all the benefits of the existing pack whilst cutting costs by 30%.*

2.3.1 Documentary Evidence

The documentary evidence is categorised as follows:

- (i) Original briefs, quotes & schedules.
- (ii) Design reviews and general reports.
- (iii) Correspondence to/from client.
- (iv) Correspondence to/from third parties.
- (v) Quotations from suppliers.

Appendix 1: General company information.

2.3.1.1. Index

The Soulagil case study index can be found on the CD.

2.3.2 Project Summary

This document provides a summary or overview of the events that occurred during the execution of the project named 'Soulagil'. The project was carried out by CfID on behalf of P&G between February 18th and October 21st 1992.

The Brief

The brief was to re-design the packaging of an existing throat spray product known as Soulagil in Europe and Ultra Chloraseptic in the UK. The existing packaging was popular with a number of functional and ergonomic benefits, but was extremely expensive to produce. The challenge was to achieve a 30% cost reduction whilst



maintaining the key benefits of the existing pack. The key benefits to retain were the protection of the actuator when not in use, the prevention of deterioration of the Soulagil liquid through exposure to UV, and the provision of a user-friendly method of application for the end user.

The Result

The existing product consisted of a custom produced bottle with an off centre neck sheathed in a label which protected the liquid from UV deterioration. The bottle was closed off with an over-cap within which sat a long armed actuator. Once the cap was removed, the user would swing the actuator round to gain better access to the application area (the throat).

The final proposed design (Fig. 40) consisted of a bottle with an over-cap, which both managed and contained the long arm actuator. The actuator would be stored down the side of the product when not in use. The user would then remove the actuator and attach it to the pump in order to dispense the liquid. Once dispensed the user would replace the actuator in the storage position.

The proposed design replaced the existing custom bottle with a standard off-the-shelf component. The bottle was coloured so the expensive sheathing could be replaced with an inexpensive label. The large over-cap was replaced with a smaller one that reduced material costs. The overall package was smaller & lighter so assisting distribution. The new actuator was a modification of the existing tool, reducing the need for expensive re-tooling. The final design ultimately resulted in a production cost saving of 25% whilst maintaining the key benefits of the existing pack.



Fig. 40. Computer Visualisation of the final design proposal

This project was principally investigative and as such the scope of the project was limited to the earlier conceptual stages of the project, the final result being a specification for costing rather than a specification for manufacture.

2.3.2.1. Pre-Design Stage

This was probably the first major project for a major client that the CfID had undertaken since its inception and we were obviously very keen to see what we could achieve for them. Whilst we were confident of our abilities to impress them on a creative/design level, we were aware that the use of our newly learned visualisation capabilities would be extremely important. At this stage we only employed Alias and AutoCAD⁷, we had not yet invested in Pro/Engineer. This obviously had an effect on the way in which we carried out the project.

Through the marketing activities of what was then Polytechnic Products (the business arm of what was then Newcastle Polytechnic), P&G had confirmed their intention to work with CfID, however it was almost a full year later that the first stages of the project actually commenced. This followed a meeting between P&G and a representative of CfID on 26th February 1992. The project commenced the following day.

⁷ AutoCAD™: See Glossary



2.3.2.2. Concept Generation Stage

Brainstorm & Information Gathering

The project started in a traditional manner with a series of questions being asked to both interrogate the existing design and to try and understand the problems that the design faced in both ergonomic and practical terms. In parallel with this, a group brainstorming session defined a direction for the project; sketches and words were used to keep a strong record of the thinking process (Fig. 41).

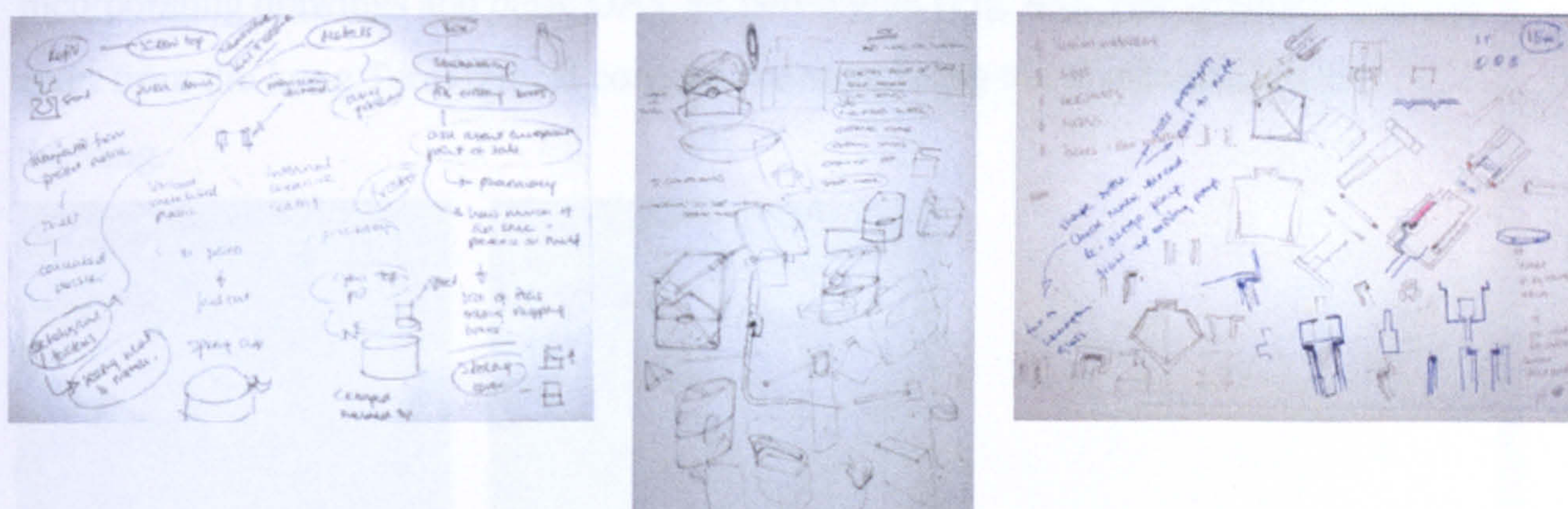

Fig. 41. Worksheets from initial brainstorming session

Initial Concepts

During the initial phase the client wanted our thinking to be as free as possible so provided us with very little information about the project, this actually worked in the opposite way to that intended and resulted in us focusing on only specific parts of the product. At this time we felt that the bottle was the key focus and this is shown in our own development (Fig. 42), it was only a very short time before the initial presentation that we come up with a more radical concept (Fig. 43 left). During this period, work was carried out in a very traditional manner, using sketches and hand drawn general arrangement (GA) drawings to obtain initial concept feasibility.

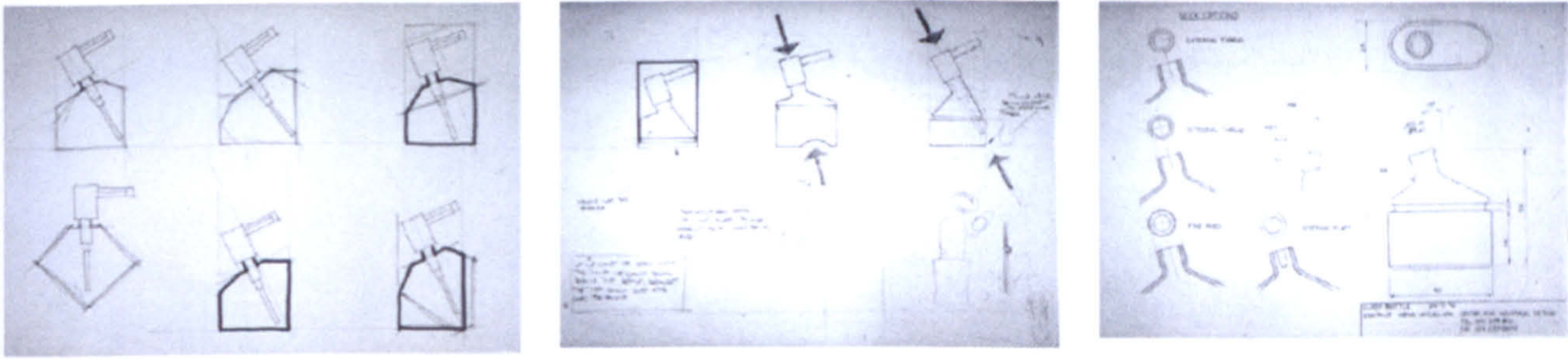

Fig. 42. Initial Concept Sketches and GA's

The initial concepts are presented by means of boards showing analysis information & incorporating drawings and basic GAs, all non-digital (Fig. 43). The feedback was that apart from the Long Term radical concept, we were being too constrained in our thinking.

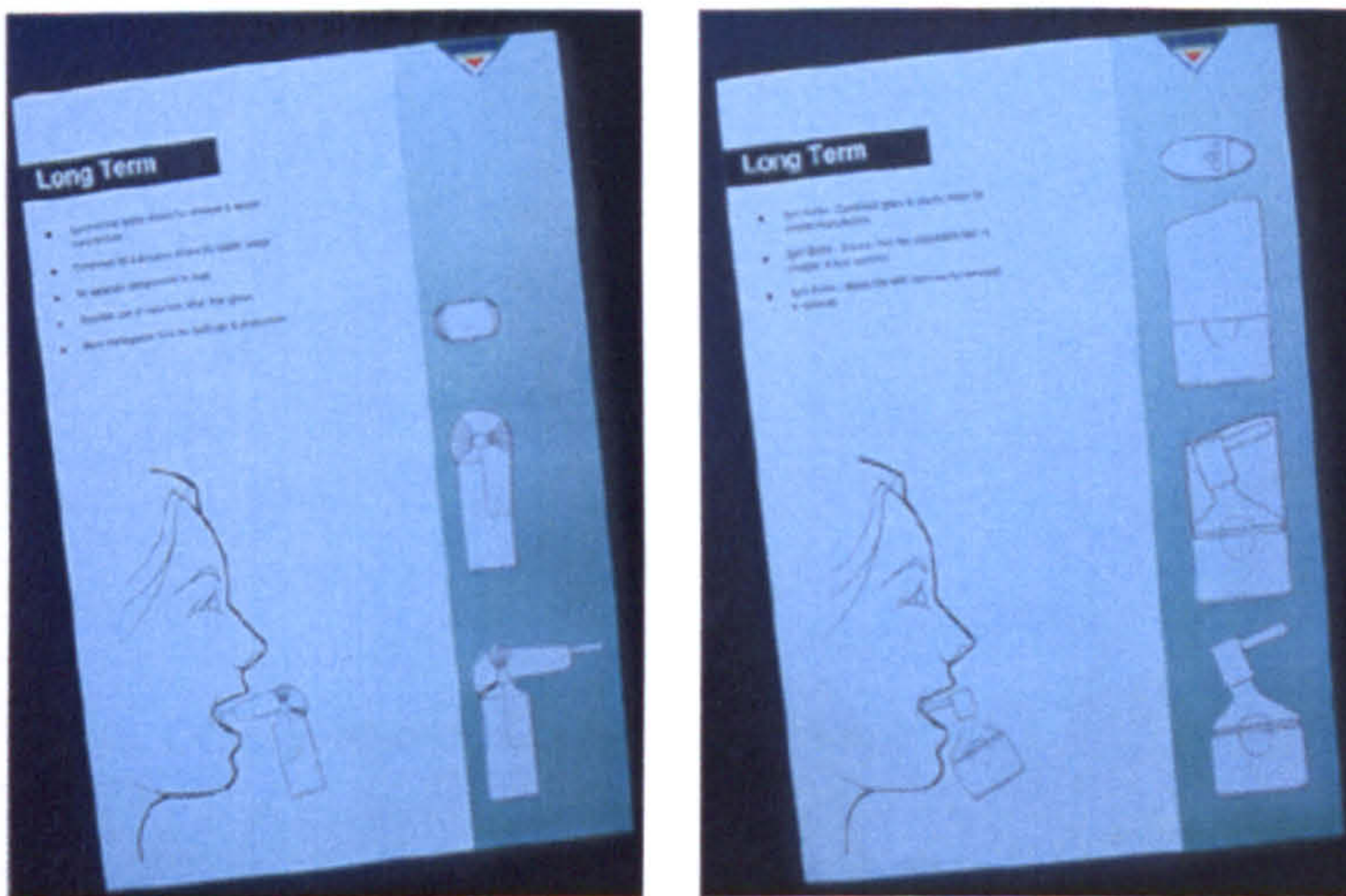

Fig. 43. Boards from Initial Concept Presentation

2.3.2.3. Design Development Stage



Concept Regeneration

Following this presentation we visited a manufacturing plant in order to establish some production parameters, this was followed by a period of concept regeneration, as the design was totally re-evaluated. Through the use of sketches (Fig. 44), drawings and GAs (Fig. 45) we generated four new concepts.

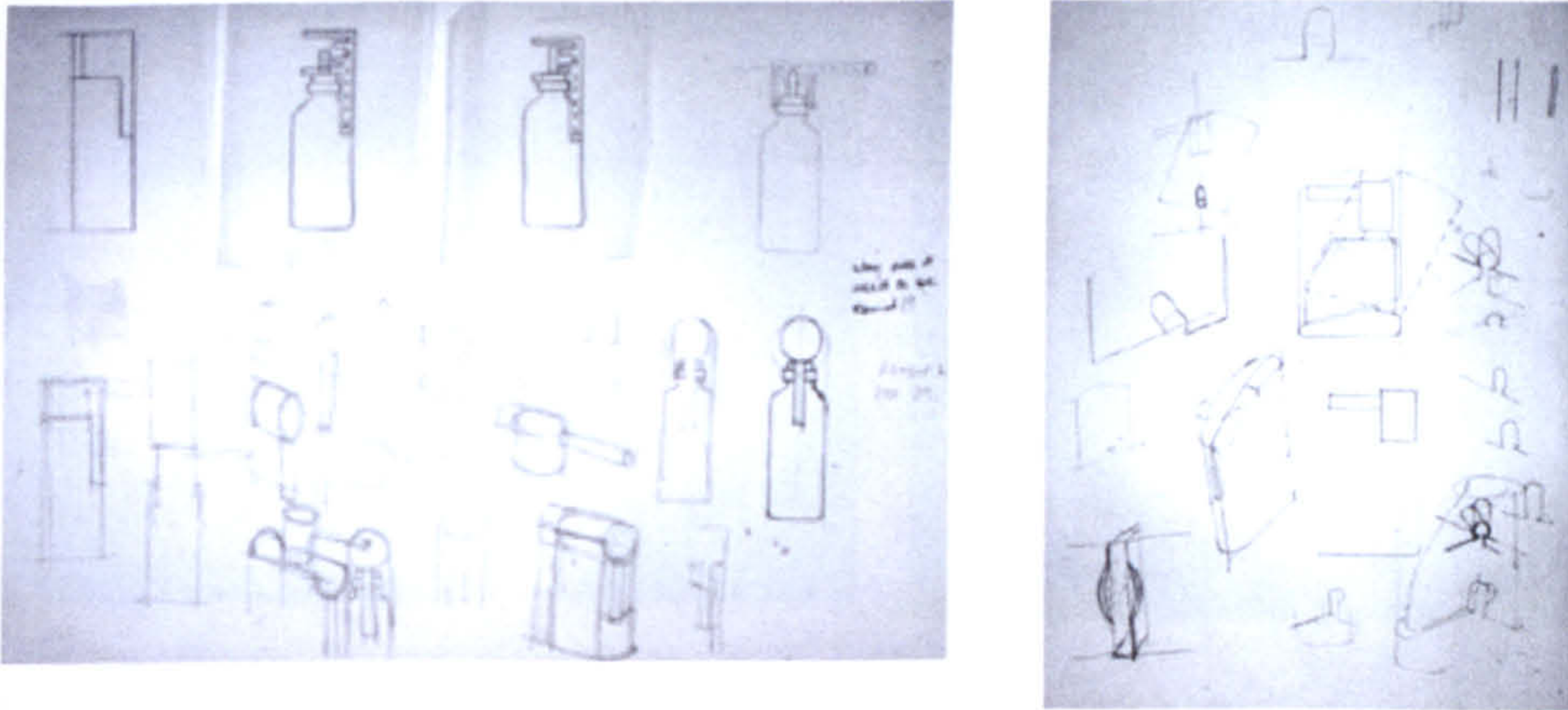

Fig. 44. Concept regeneration through the use of sketches

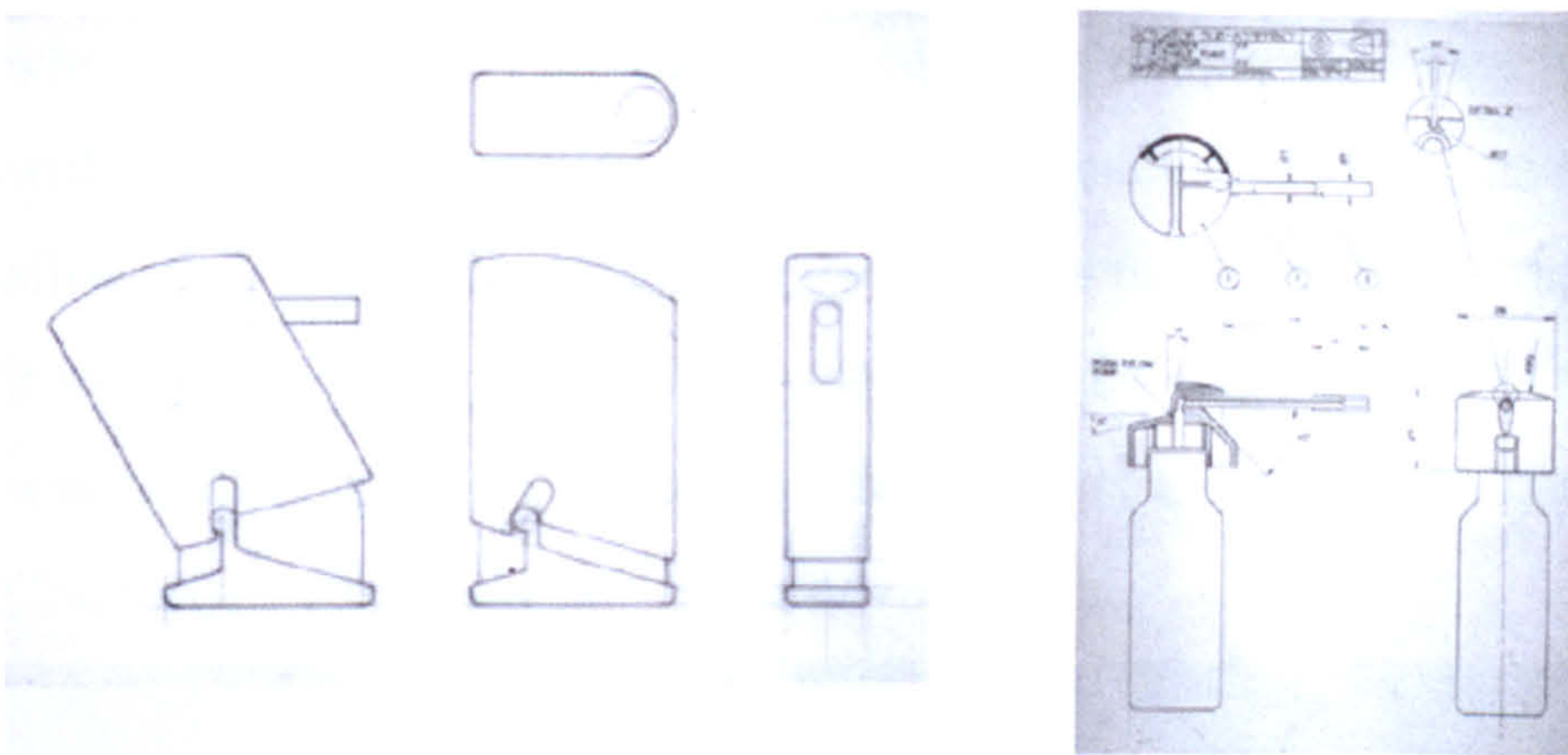

Fig. 45. Concept regeneration through the use of GA's

These concepts were presented at the end of Phase 1, using presentation illustrations as before (Fig. 43 & Fig. 46) but this time they were also accompanied by a combination of computer generated images (Fig. 48) and models (Fig. 47).

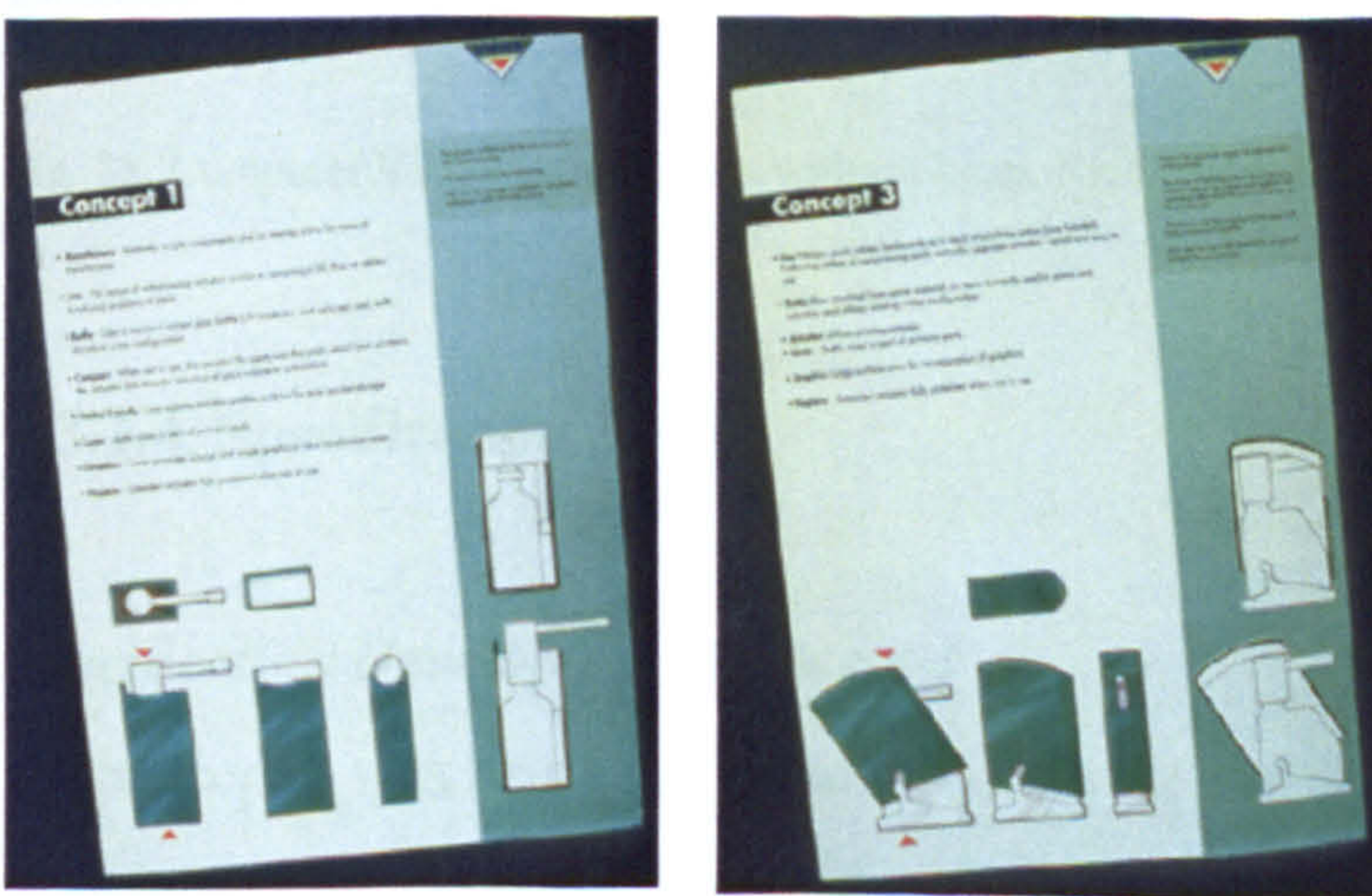

Fig. 46. Phase 1 presentation boards

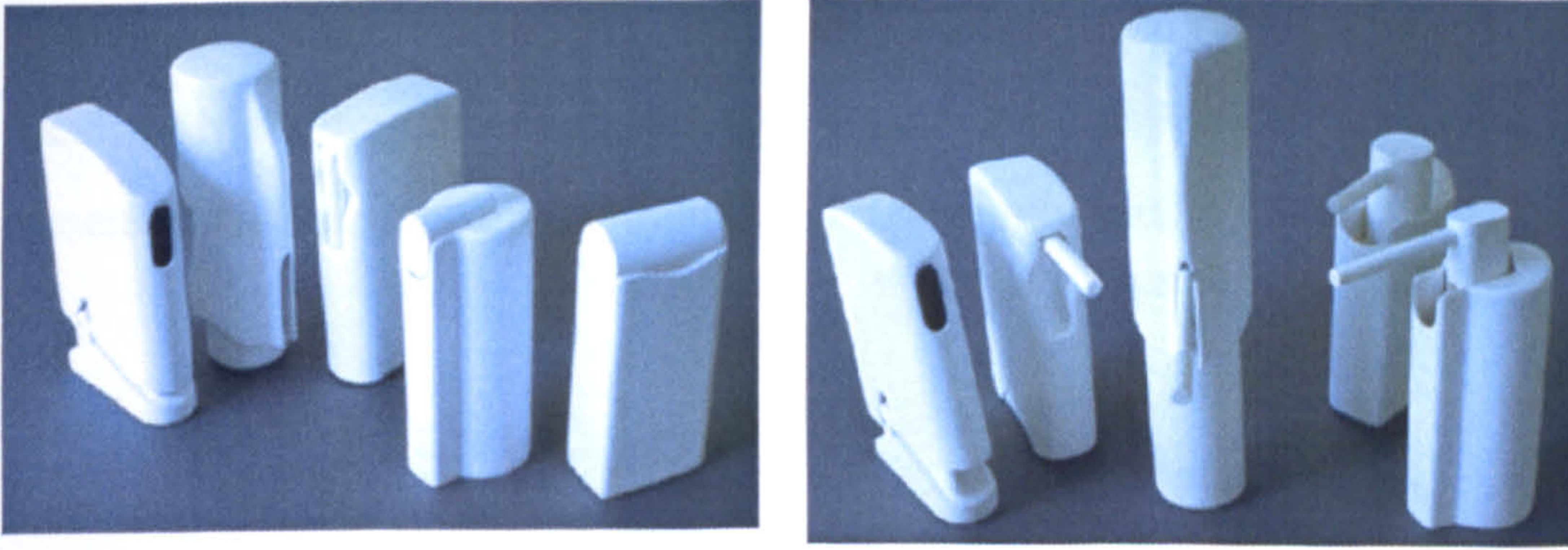

Fig. 47. Appearance models

The concept was that the client could hold a model of the product in the hand (Fig. 47), whilst simultaneously viewing a visualisation of the product on screen, showed both with and without labels (Fig. 48). This combination of digital and non-digital media allowed us to fully communicate the concepts to the client in a much shorter time than it would have taken to make full appearance models. Being able to hold the product was essential as it was a hand held device. This approach was extremely successful and Concept 1 was chosen for further development.

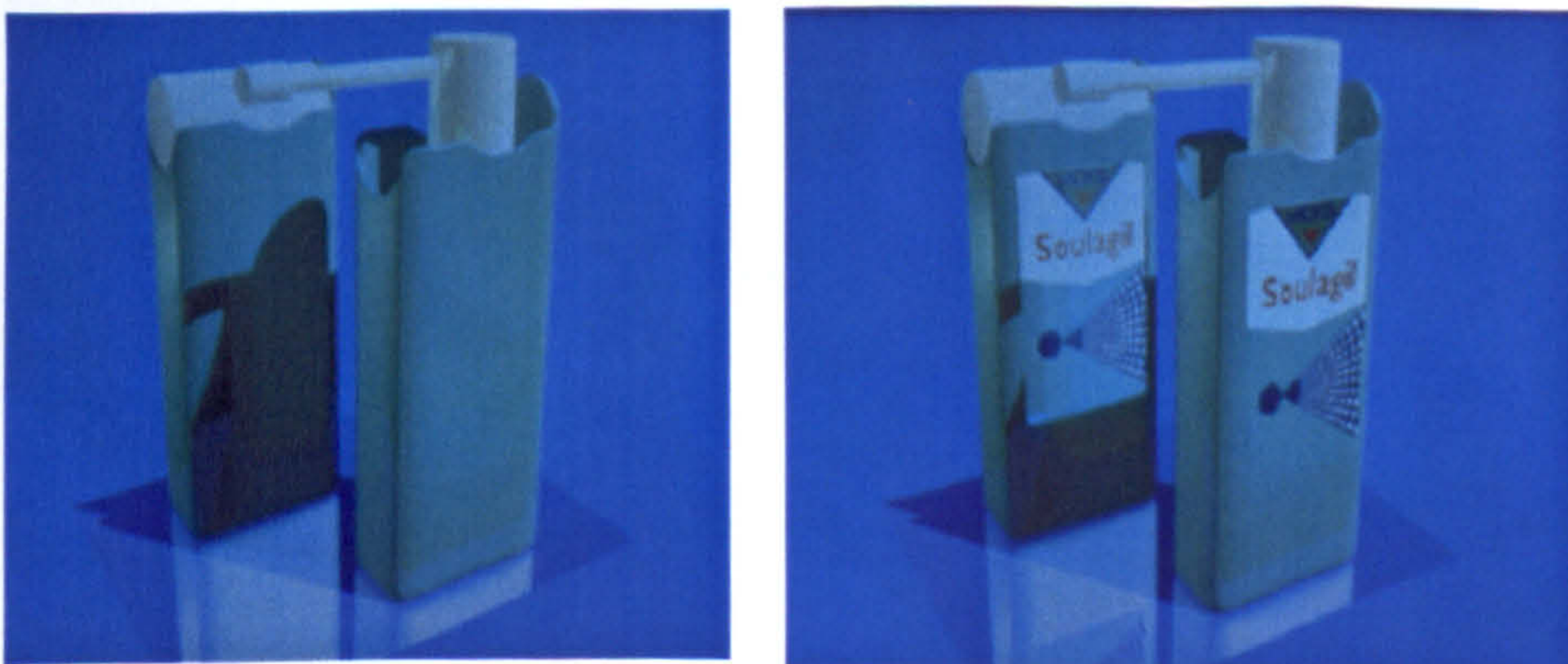

Fig. 48. Computer Visualisations (left: without label. Right: with label)

2.3.2.4. Specification Stage



Specification Development Concept 1

As concept 1 was being developed through the use of AutoCAD based technical drawings (Fig. 49), it was found that further cost savings might be made through the use of an off the shelf standard bottle. This led to the development of another concept

that was presented in addition to the previous concepts at the meeting of the European Heads of Marketing meeting at P&G in Egham on 15th May 1992. This concept was presented via the same mixed digital and non-digital method as before (Fig. 50)

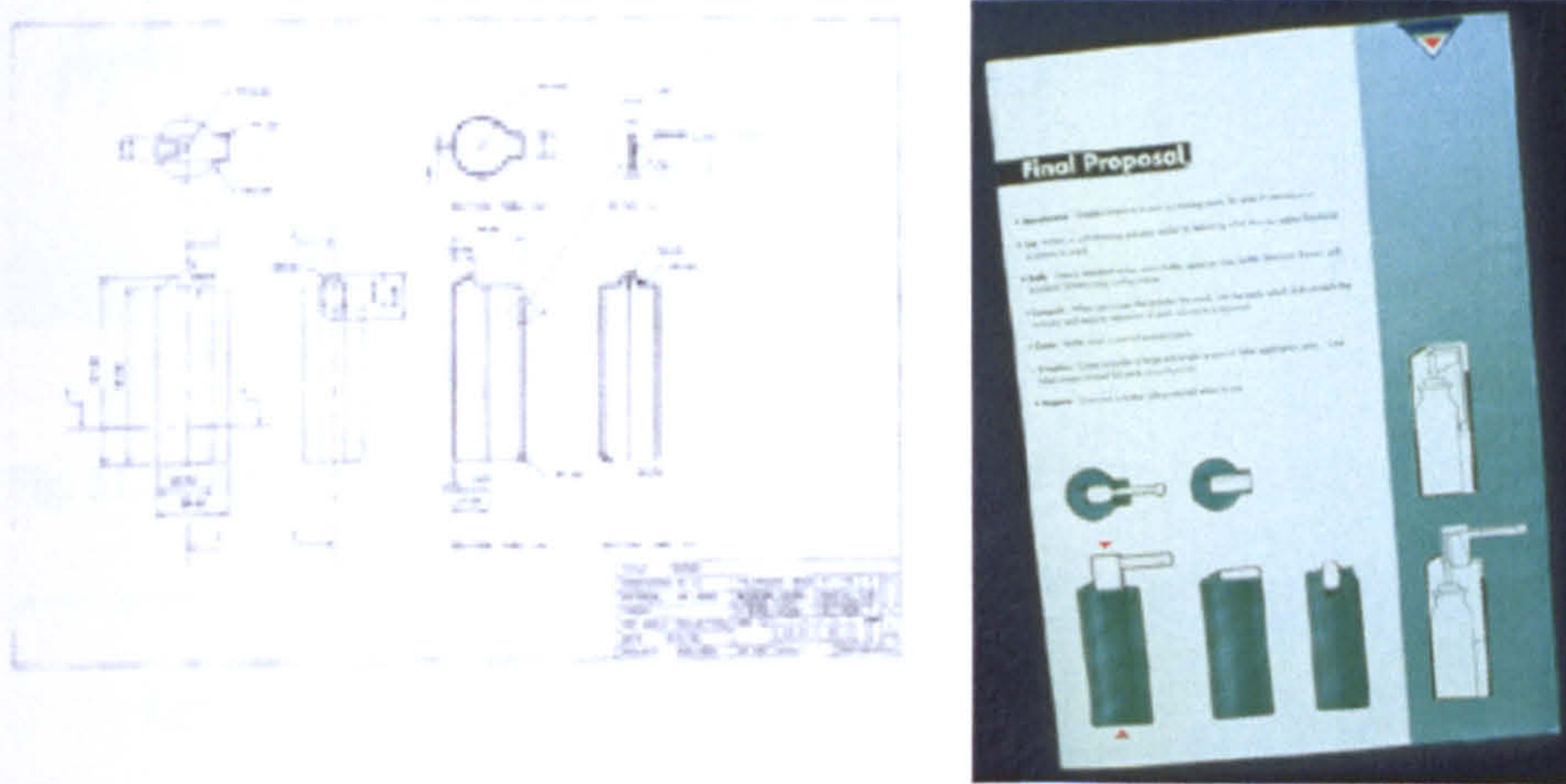

Fig. 49. Concept development. Left: AutoCAD drawing. Right: Presentation Illustration

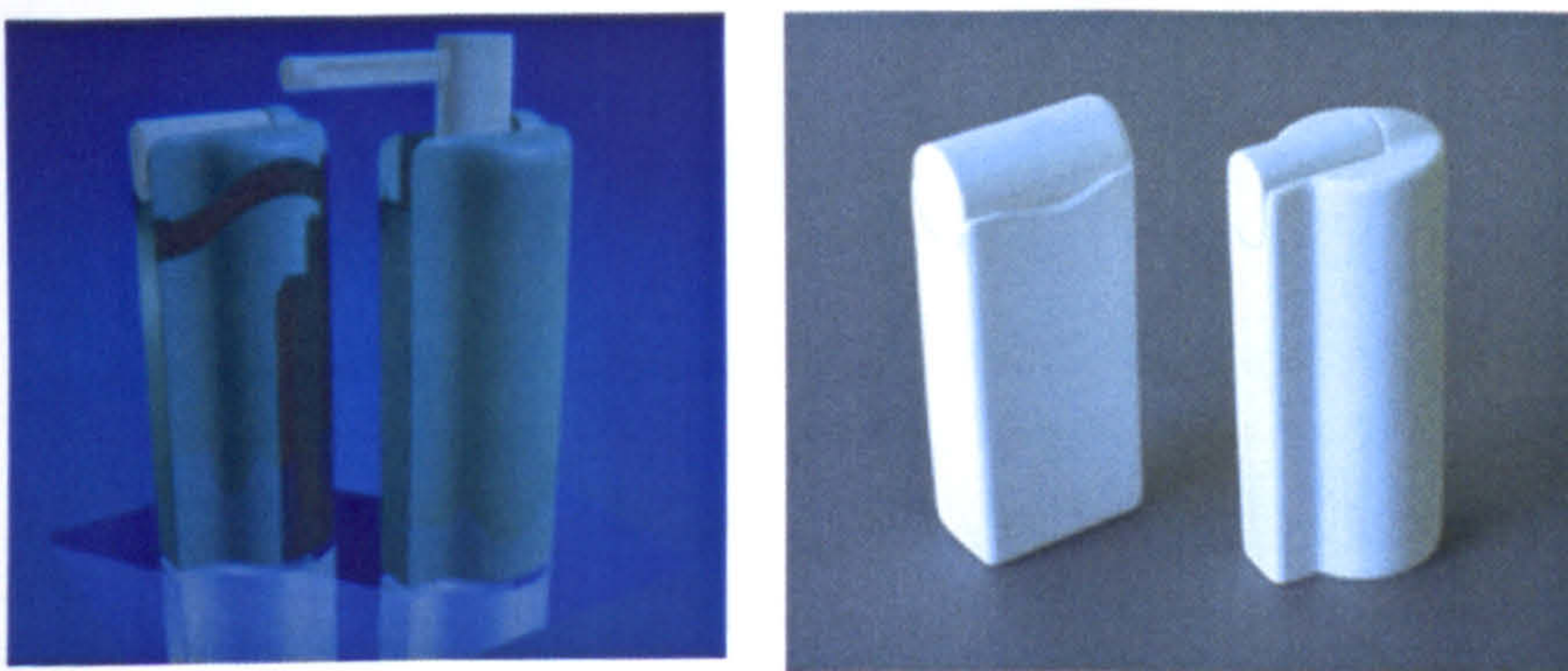

Fig. 50. Concept development. Left: Computer Visualisation. Right: Appearance Model

Further Development

It was now felt that there was a viable concept in place and one that should be taken through to full specification for costing. However during this phase CfID realised that there may be a further development of the design which would enable further cost reductions, this involved a reduction in the amount of plastic used, a cheaper bottle and labelling method and an adjustment to the tooling of the existing actuator rather than a full new tool. This new concept was developed as before using a combination of sketches, hand drawn GA's, 2D CAD drawings and computer visualisations (Fig. 51 & Fig. 52).

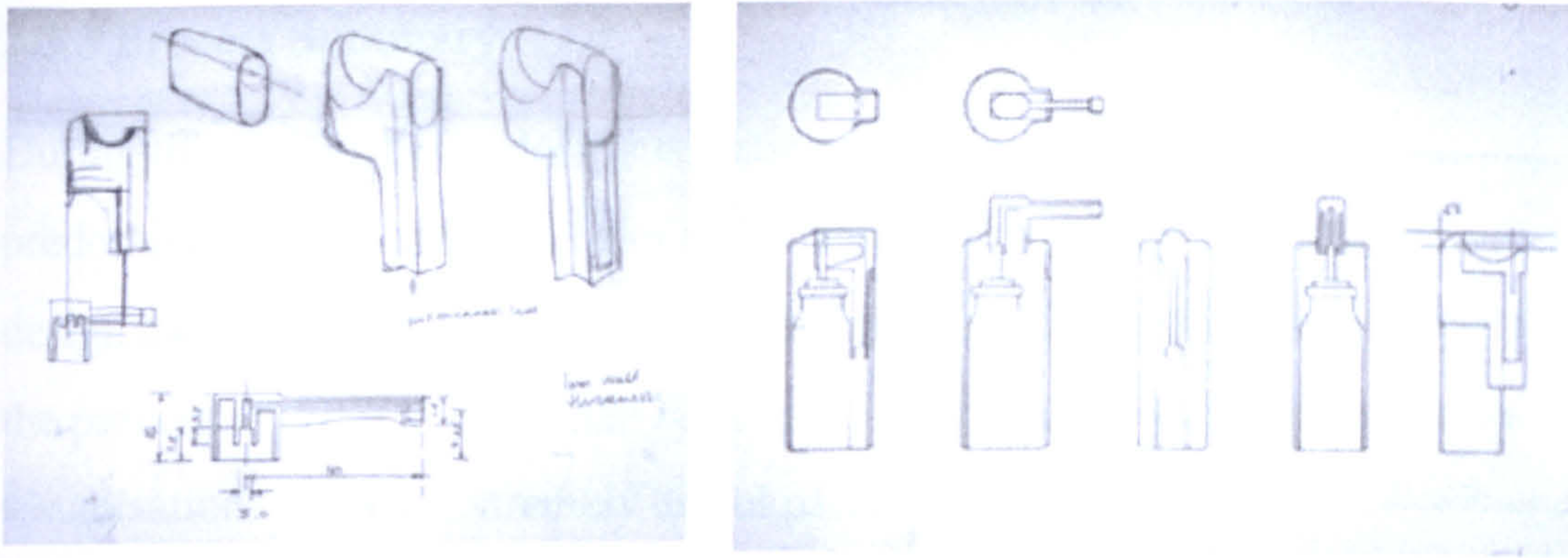

Fig. 51. Further concept development. Left: Sketches and right: Hand drawn GA

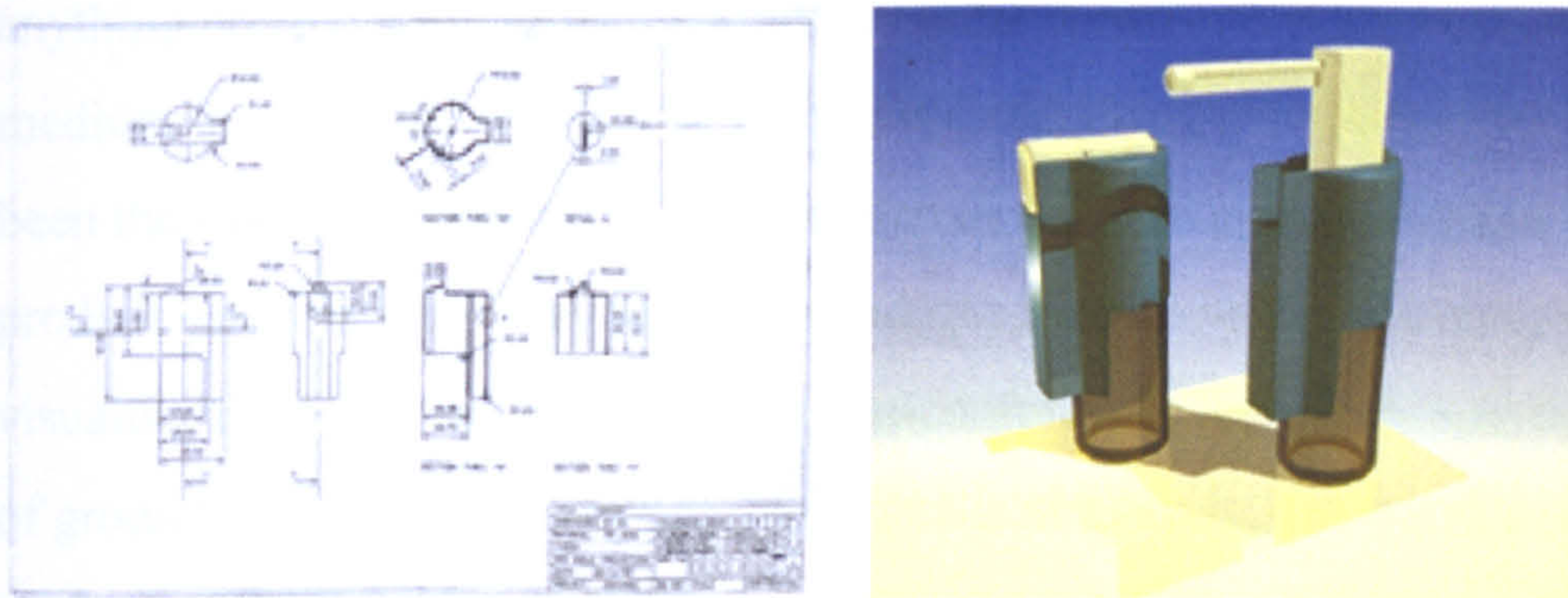

Fig. 52. Further concept development. Left: 2D AutoCAD drawings and right: Computer Visualisation

Final Specification & Liaison

There follows a long period where the design is further revised, specification drawings are issued (Fig. 53) and costs are received, during this time issues regarding the actuator are discussed and resolved. On 16th October 1992, a final presentation of the design (Fig. 40) and costs are given at the Centre, showing the revised design to be the most economical option.

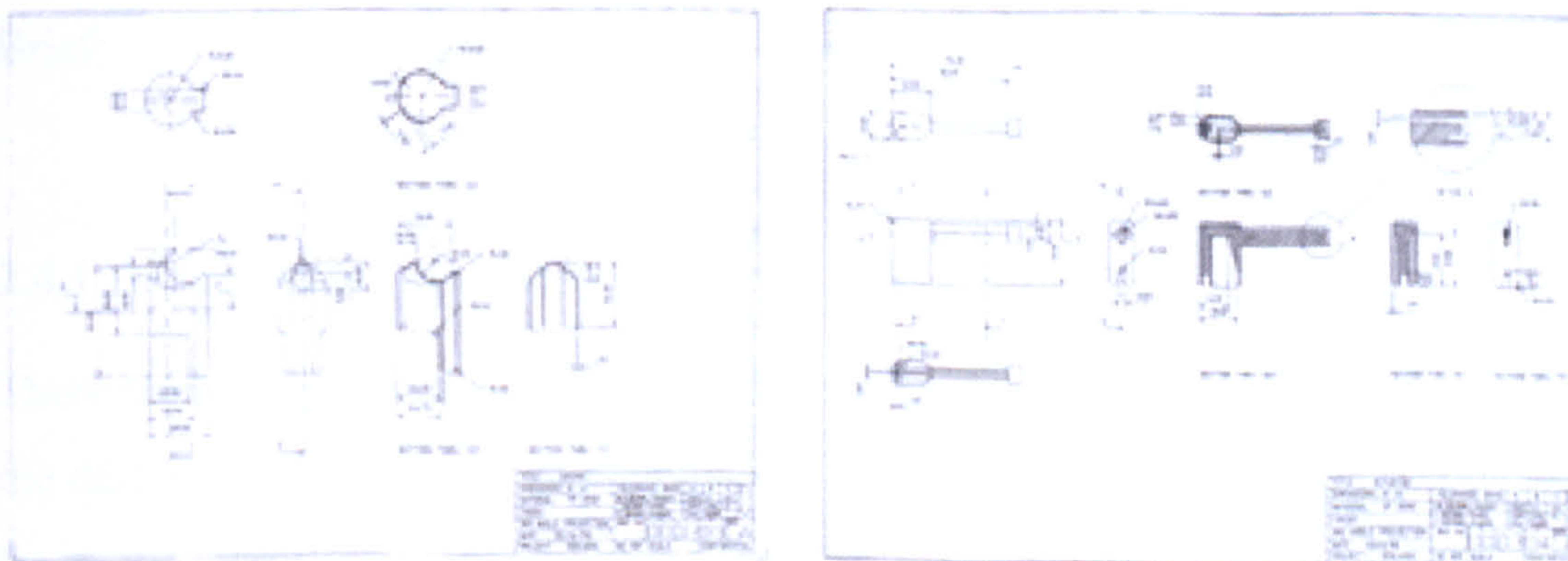

Fig. 53. Final specification drawings for case and actuator

2.3.3 Process Summary

During this project computer visualisation is used to great effect, but it is used predominantly as a communicator and a facilitator for design making rather than as a design tool. Sketches and rough technical drawings (GAs) are used heavily throughout the process in order to continually evaluate the design. Models and computer visualisations were an extremely useful part of the process but they were done much more for the client than for the designer. This is probably due to two factors; the only 3D software that was available and employed was principally a visualisation software, anything created within this medium had to be re-created in a specification driven medium in order that it might be communicated to manufacturers, this would not have been the case had the product been created in a solid modeller such as Pro/E. Also, the product was relatively easy to understand, the mechanisms were simple and easy to visualise, the forms were reasonably non-complex, the designer was able to cover a lot of ground with their own 'minds eye' visualisation tools, the use of computer media performed a confirmation rather than an exploration function. However, what this project most strongly showed was the power of mixed media, of taking the most appropriate elements from each media and mixing them to form a complete and powerful communication package.

2.4 Case Study 3: Medis

Client: *Department of Health Scotland*

Product: *Medis*

Brief: *The design of a terminal and associated interface to allow patients to access their personal medical records held on an optical card.*

2.4.1 Documentary Evidence

There are two sets of documentary evidence for this project, the evidence relating to the design and prototyping of the physical terminal itself, and the evidence relating to the design, development and implementation of the interface. The documentary evidence is categorised as follows:

Documentation Contents: Product

- (i) Original briefs, quotes, schedules and contracts
- (ii) Design reviews and general reports.
- (iii) Client Correspondence.
- (iv) Third Party Correspondence.
- (v) Quotations from suppliers.
- (vi) IPR: patents, trademarks & design registration

Appendix 1: Supplier information.

Appendix 2: Research material

Documentation Contents: Interface

- (i) Client Correspondence.
- (ii) Third Party Correspondence.
- (iii) Design reviews and general reports.
- (iv) Interface Analysis / Research
- (v) Interface Specification

2.4.1.1. Index

The case study index can be found on the CD.



2.4.2 Project Summary

This document provides a summary or overview of the events that occurred during the execution of the project named 'Medis'. The project was carried out by the Centre for Industrial Design on behalf of the Department of Health in Scotland and spanned a timescale between April 7th 1994 and January 24th 1996, however the core work was carried out between 28th July 1994 and 15th June 1995. This project differs to the other case studies in that it comprised the design of both hard and soft entities, a product and a computer interface. The main focus of this case study is the design of the product, however the interface is included as a relevant part of the project as a whole.

The Brief

The project was linked to a research programme, which was, in response to government legislation, assessing the effect of allowing patients to have access to their personal medical records via an optical card. The information on the cards was accessible via a stand-alone terminal. It was felt that the existing unit, which had been described unflatteringly as a 'brown steel coffin' was having an adverse effect on the findings. The Centre for Industrial Design were therefore commissioned to design a user-friendly unit, which had to contain a number of pre-determined hardware components, and had to allow for a range of ages and environmental locations. The Centre was further commissioned to redesign the interface which had to be sympathetic to the needs of the end user, be simple to use and easy to understand. Both the interface and the unit had to be friendly whilst retaining user confidence in the accuracy and security of the information presented.

The Result

The existing physical product consisted of a large brown steel box (Fig. 54) that had no sympathetic qualities towards the end user. It was monolithic, had no privacy provision and a screen that was at a height appropriate for only certain users.

The resulting product (Fig. 54) had a large curving screen to give a feeling of privacy to the user and provided an optimum location for branding and instructions. The large flat surface gave the user a place to put bags or printouts. The angled screen enabled a wider range of people to use the unit, from children, to the wheelchair bound through to a standing adult. The hardware was concealed in a simple 'cupboard' so allowing easy access to the various components for maintenance. The use of coloured laminates and soft, calm colours helped the unit fit in with the proposed location, the bright and friendly Inverurie Health Centre.

The existing interface was DOS based on a bright blue background. The coding platform gave no opportunity for friendly graphics, and users found it difficult both to navigate through as well as to read. The resultant interface took colour cues from the

product, making it as calm and as friendly as possible. It consisted of a main information window and a strip along the right hand side within which the 4 most commonly used buttons would appear. The buttons always appeared in the same place so that the user would not get confused. Pictorial images were used wherever possible to assist the user, i.e. for entering a card, removing a printout etc.

As a result of the design proposals the research programme received extensions in terms of both time and money. A MEDIS unit was placed on show in St Andrews House, the Government offices in Edinburgh.



Fig. 54. Existing unit (left) and right: Medis unit

The intention of this project was to create prototype units that would be used to facilitate the research programme; the initial proposal was for a single prototype followed by four more. However, as the project progressed the clients realised that multiple units would over stretch their resources and as a result only two prototype units were made. The scope of the interface element was to design an interface that could be implemented and used within the prototype units.

2.4.2.1. Pre-Design Stage

Unlike the other two case studies presented the clients in this case were relatively unused to buying design. The first stages of negotiation involved many meetings between the various parties through which we developed a greater understanding of both the political and design complexities of the project. This resulted in CfID drafting



Fig. 55. Left: Kintore Health Centre. Right: Inverurie Health Centre

Initial Concept Generation

Following the site visits we made scale models of each of the proposed sites. We used these to illustrate user movements and consequently to identify a likely location and space allocation for the terminal (Fig. 55). Concurrently with the research and planning stage we built full size soft models of all the components and started to look at possible configurations for the terminal (Fig. 56). We combined the results of the research report with these to create a number of configuration concepts that we presented on 25th August 1994 (Fig. 57). This stage was very much focused on getting to grips with the issues and this was done primarily through the medium of sketching and drawing.

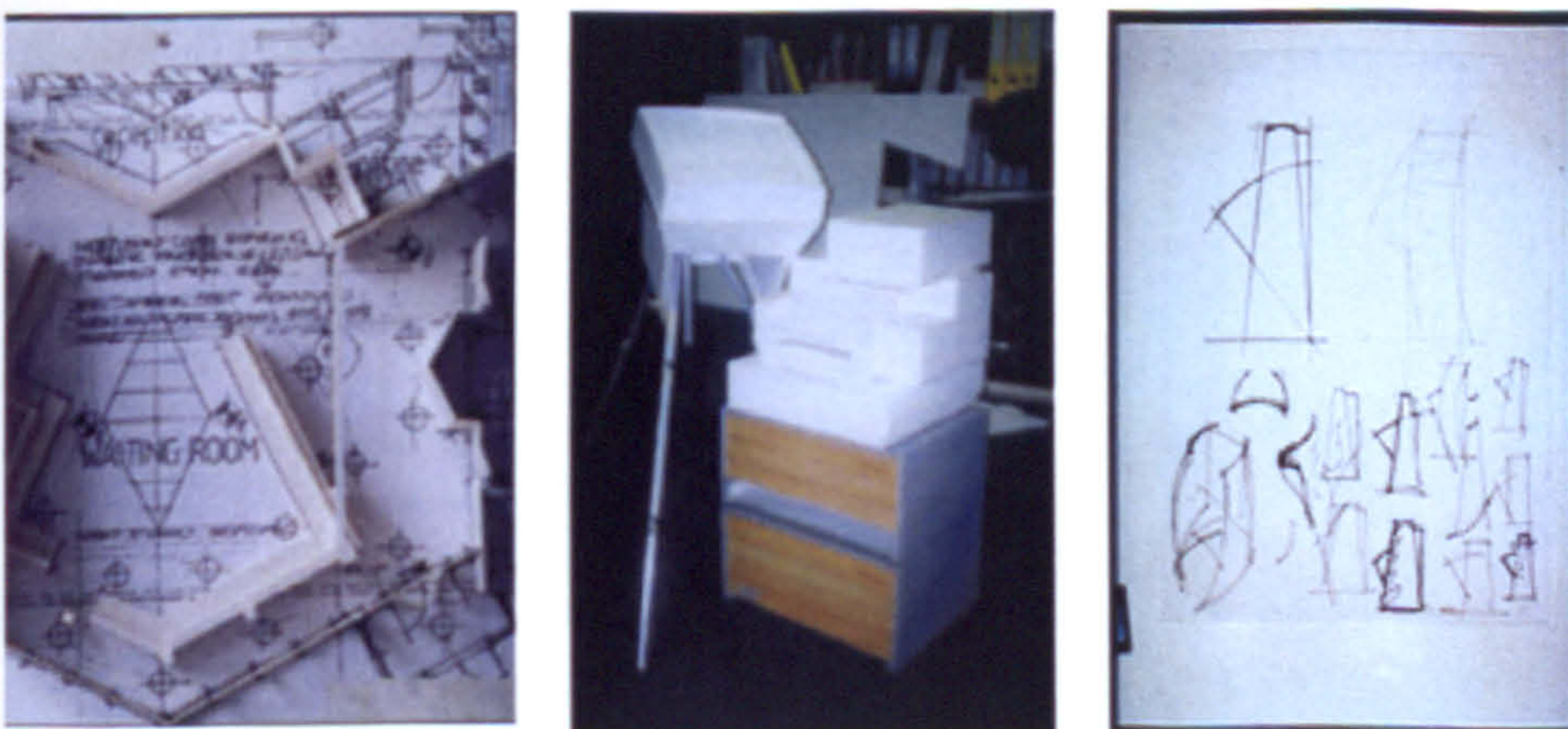

Fig. 56. Left: Contextual Model of Inverurie Health Centre
Middle: Full size configuration rigs. Right: Initial configuration sketches



Fig. 57. Presentation boards for initial presentation

2.4.2.3. Design Development Stage

Concept Development

Following this presentation the asymmetrical concept, concept 3, was a clear favourite and development was continued along this theme. Continuing to use sketches, basic rigs & scale soft models to develop the concept (Fig. 58), further developments of the asymmetric concept were shown at a progress meeting on 4th October 1994 at which the idea for the product name: 'Medis' was presented for the first time. With the name approved in principle, a trademark search was commissioned. Whilst the client was able to grasp the basic ergonomic concepts through the use of the rigs, this meeting identified the need to build a full size model as soon as possible.



Fig. 58. Left: development drawing of asymmetric concept. Middle: Scale model. Right: Full size test rig.

Development moved quickly on with the building of the first full size soft model (Fig. 59 left). This model proved that the ergonomic and scale issues within the product were nearly resolved and following approval of this model we proceeded to develop the design in more detail. The next stage of development involved us building the components digitally in 3D (Fig. 59 right); we were then able to build some concepts around this 3D 'package' knowing that our basic scale and ergonomic requirements were correct (Fig. 60 left). We were also able to build models of the potential sites for the terminal, and place it virtually within these sites, this enabled us look at the spatial impact of the terminal and assess how it would look in-situ (Fig. 60 middle). During this stage we had also considered the manufacturing and finishing options and presented these as part of this stage (Fig. 60 right).

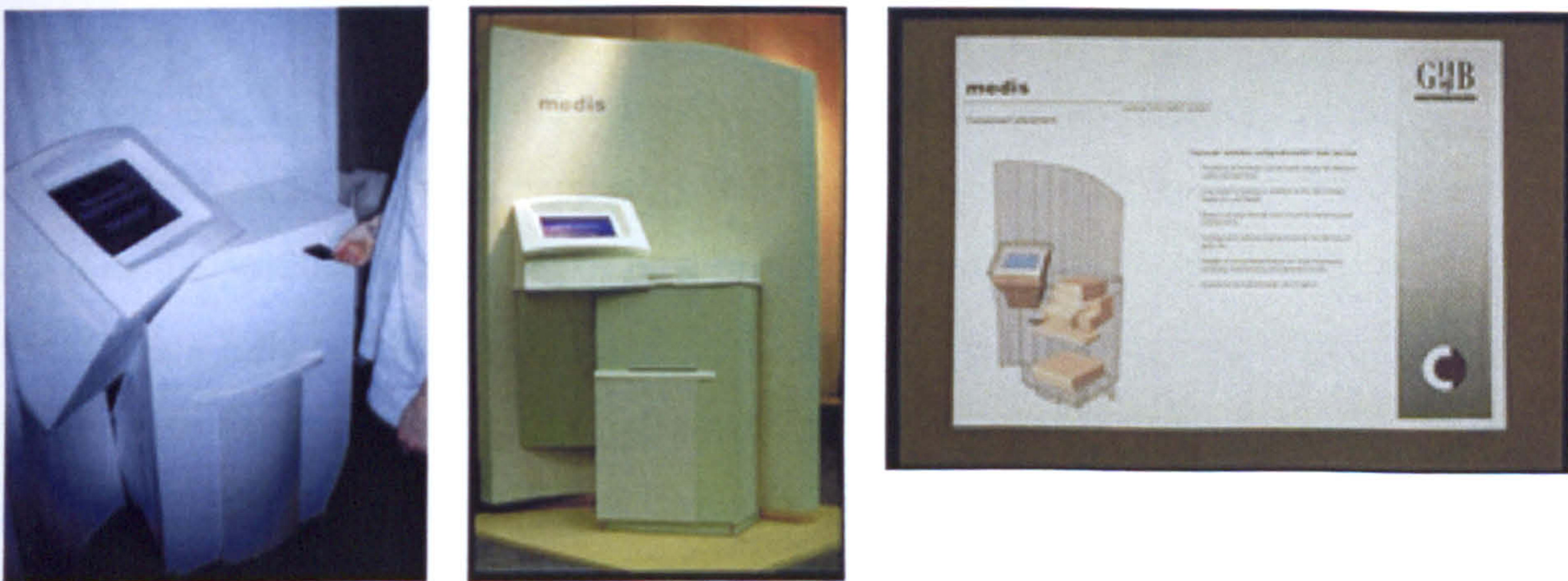

Fig. 59. Left: Full size sketch model. Middle: Full size appearance model. Right: Internal components in 3D



Fig. 60. Left: 3D concepts. Middle: The concepts in-situ. Right: Materials and finishes

Despite our ability to approximate how the product would look within the digital 3D environment we were still concerned that the full impact of the product with the proposed colours would be lost so a full size rig was built. This could take all the

components and be wired and used just as the final prototype would be. This was as close as we could take the design to the full product experience before the final commitment to prototype was made (Fig. 59 middle).

The Concept Generation & Development stage was completed on 8th November 1994 and the specification of the prototype commenced immediately. At this time the commitment to proceed with a product name and marque was given.

2.4.2.4. Specification Stage



Detail & Prototype Development

This stage involved taking the 3D model of the preferred concept presented at the last stage and developing this model to resolve all the details of the product. However despite the bulk of this work happening in 3D, sketches were still being used to work out how the product might look, or how certain issues might be resolved (Fig. 61). The result was a fully finished 3D model (Fig. 61 & Fig. 62), enabling the production of 2D information from which the prototype would be made (Fig. 62). It was also during this stage that the design of the interface commenced with the CfID attending a familiarisation meeting with EDS on 8th December 1994. The design of the interface commenced forthwith.

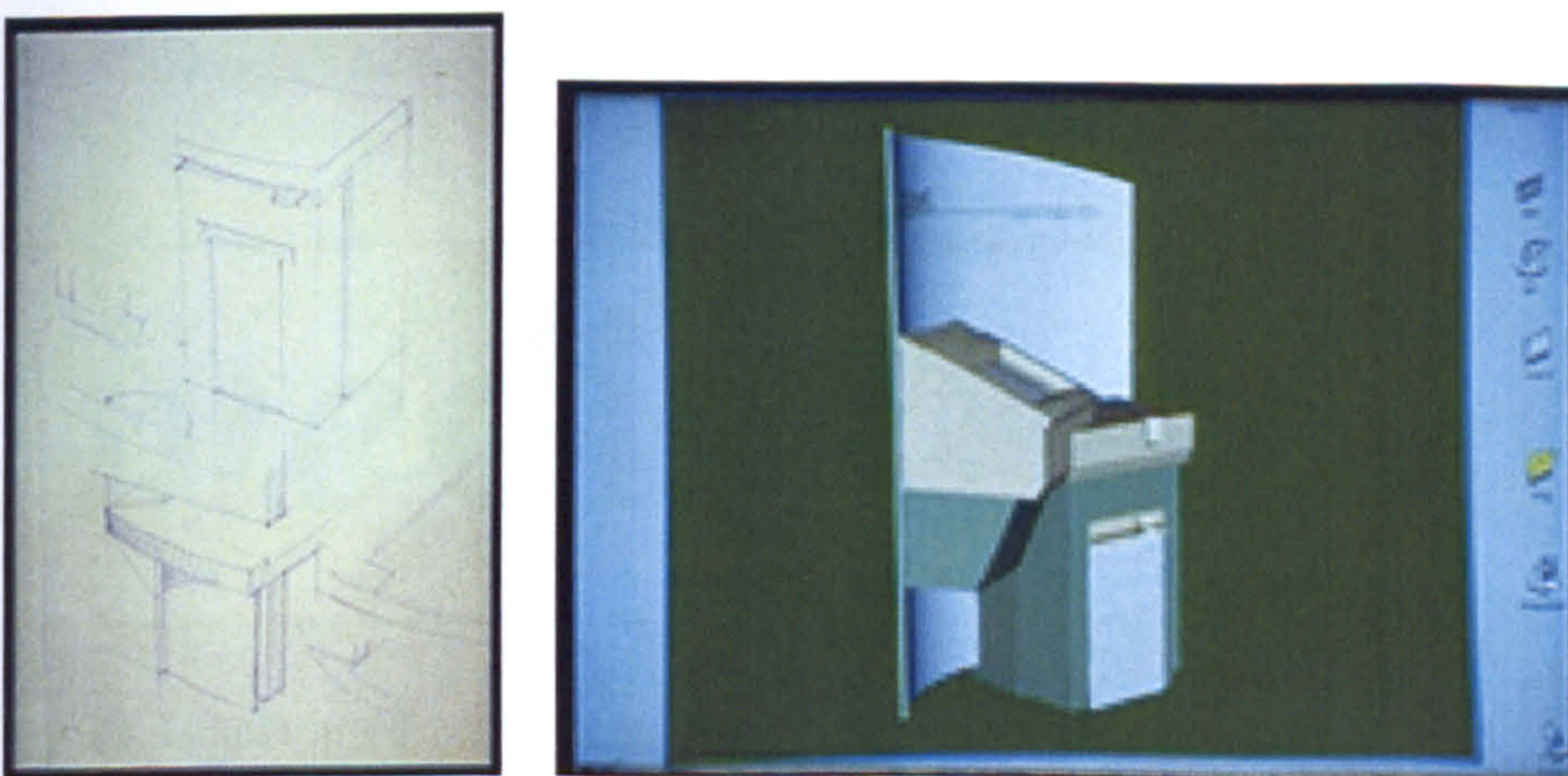

Fig. 61. Left: Working out details using sketches. Right: 3D view of the finished design

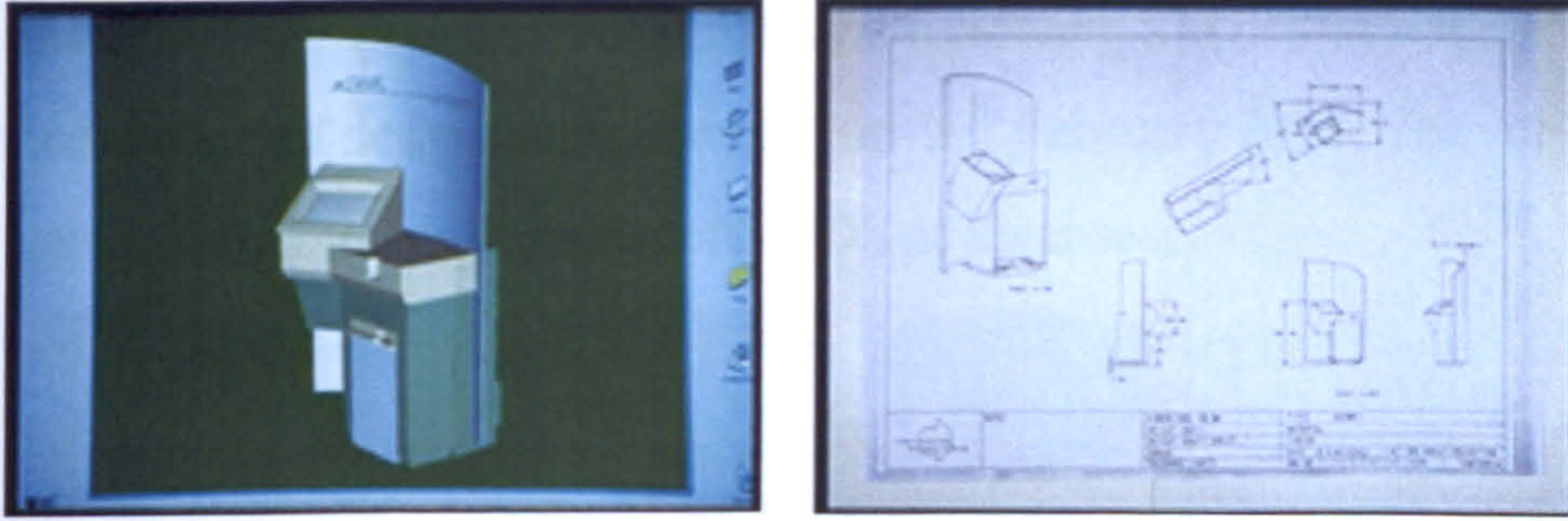

Fig. 62. Left: 3D view of the finished design. Right: 2D drawings from the 3D data

Corporate Identity

Following receipt of the trademark approval, CfID had commissioned the Chase, a graphic design consultancy, to develop some concepts for the product logo (Fig. 63 & Fig. 64 left). The chosen concept (Fig. 64 right) was to be applied to letterheads, leaflets, the optical card & carrier, as well as to the unit itself. This logo was also to be used as an integral part of the interface design.

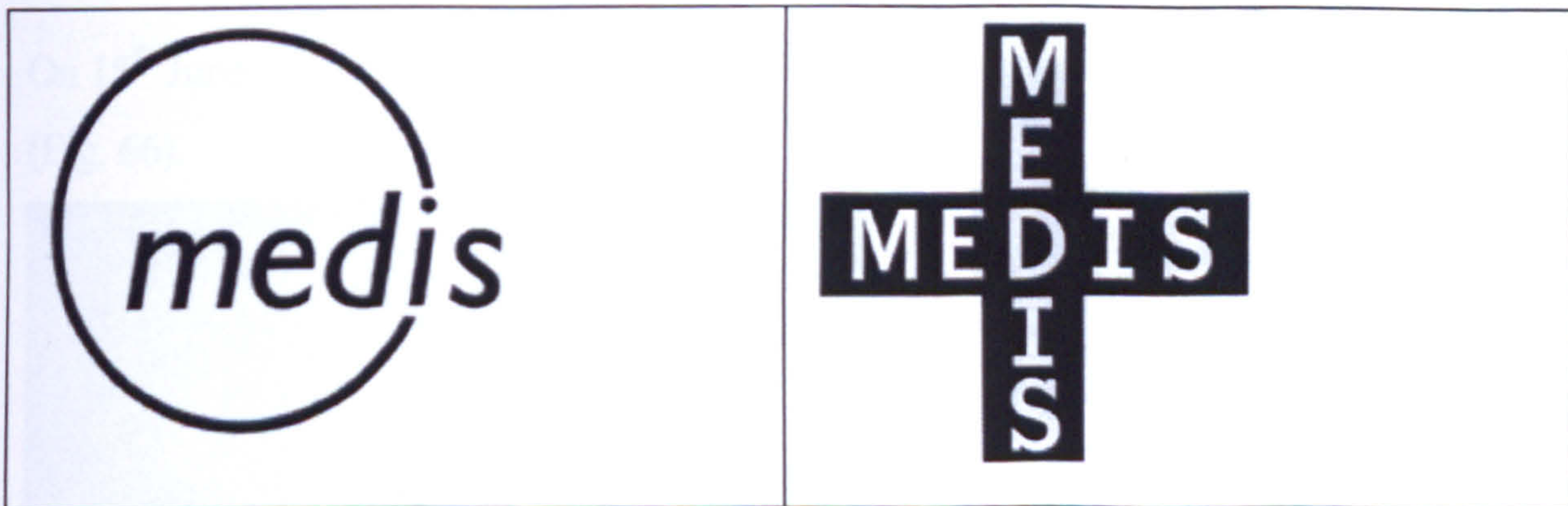

Fig. 63. Proposals for the Medis logo

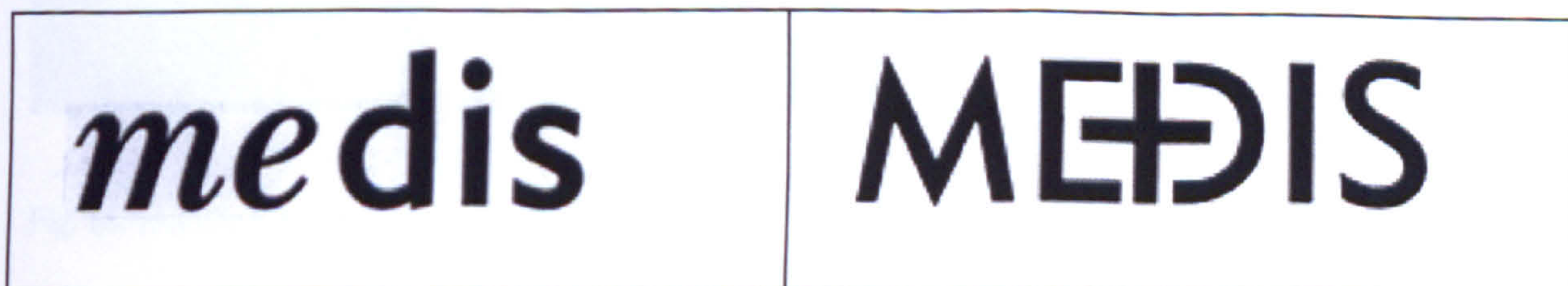

Fig. 64. Left: Proposal for the Medis logo. Right: The final logo

Prototype Production & Installation

This stage was very much a stage of hands on activity where all the component parts of the terminal were produced (Fig. 65). During this phase CfID quickly developed the

interface in conjunction with EDS and following a series of interim presentations the final interface design was presented on 16th February 1995. The interface was then implemented in conjunction with EDS at Swansea.

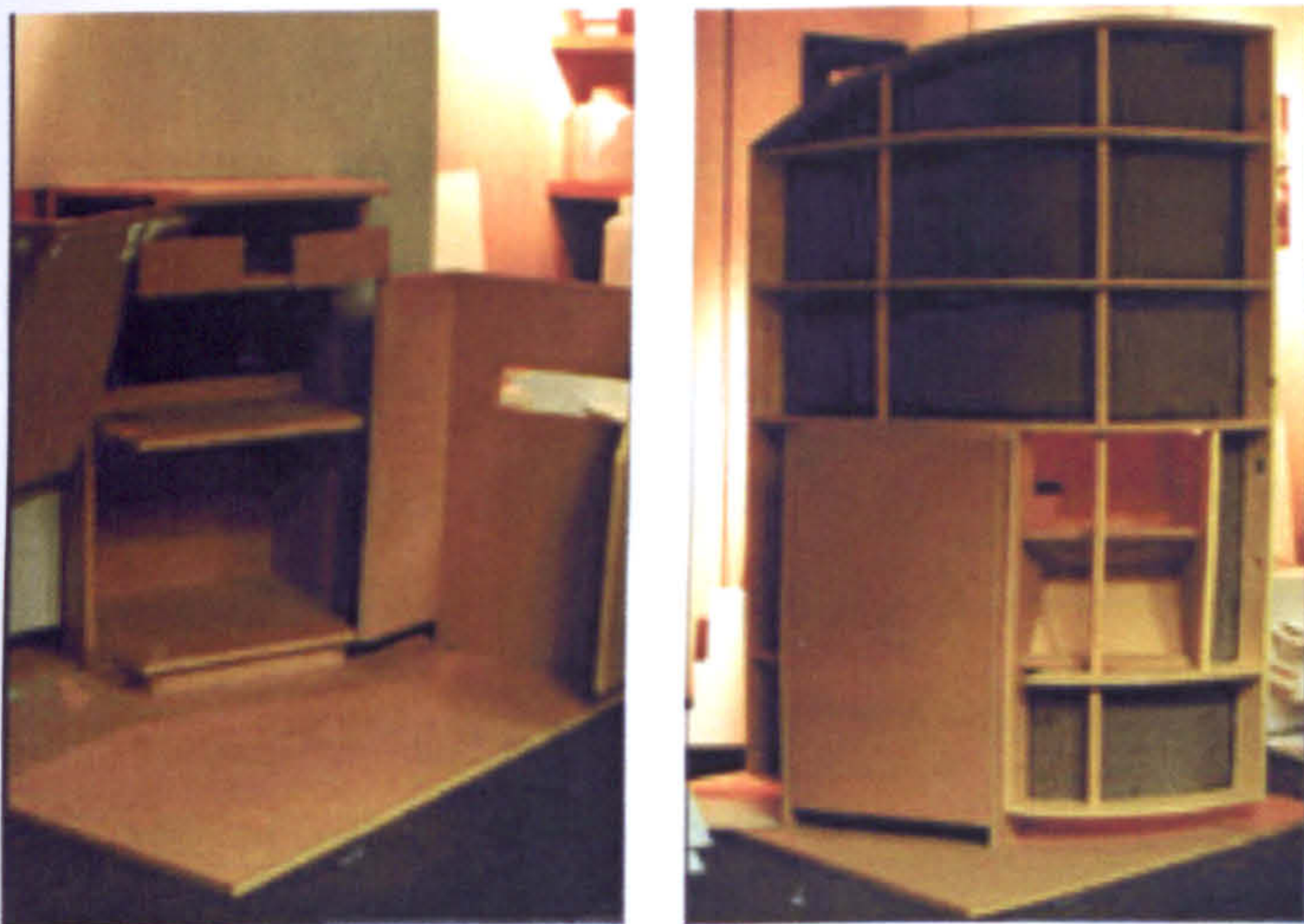

Fig. 65. Building the prototype

On 15th June 1995 CfID install the 1st completed prototype at Inverurie Health Centre (Fig. 66).



Fig. 66. Installing the prototype

2.4.3 Process Summary

This project used traditional and digital methods in very distinct stages. The first stages of the project were all about coming to terms with the issues and because of the scale of the project, getting used to all the volumes involved. The result was a very hands-on

an extensive project plan in order to persuade the client that they needed something that was ‘designed’ rather than just ‘built’. We also had to convince them that a new interface was as necessary as a new terminal and although the initial part of the contract was for the terminal only, the interface was included at a later date.

It was not clear at the early stages how much 3D modelling might contribute to the design process, whilst we believed it would have a place, we realised early on that it would have to fit alongside more traditional methods such as full scale soft modelling and rig building.

2.4.2.2. Concept Generation Stage



Planning and research

The original intention of the project was that a number of these prototype units might be built and placed in various health centres and hospitals within the region. The Pre-Design stage therefore concentrated mainly on researching these sites (Fig. 55), as well as looking at how people were using (or not!) the existing terminal. This involved a number of site visits, culminating in a report, which we presented alongside our first stage concepts. The intention of this planning & research phase was to establish: design parameters, functional/technical requirements, psychological issues, manufacturing parameters, budgets and timescales.

approach, using lots of sketching and soft modelling. However, once these basic issues were resolved, 3D modelling became a very useful tool.

Although the product appears simple, the geometry surrounding the angled & suspended monitor, combined with the curving back was especially complex. The ability to produce the 2D cutting patterns from the 3D models without doubt saved an enormous amount of time. In addition to this we were able to check component clearances very easily and put the product quickly into context to establish exactly how much space it would need and how this would affect its environment.

The use of 3D within this project was essentially more of a practical than a 'glamorous' one, and essential in resolving efficiently the technical requirements of production. The real human impact of the project came through the use of full size finished models, through which we were able to make decisions about interaction and ergonomics.

2.5 Peer Review

2.5.1 Questionnaire

The peer review of the Heuristic Map was carried via the Internet and feedback was obtained via a simple questionnaire as illustrated in Fig. 67 below.

A Heuristic Map for Digitally Integrated Design - Evaluation Questionnaire

1. Please indicate your area of expertise (please tick all that apply):
designer *design manager* *educator* *researcher*
2. Do you, your company or institution use 3D computing as a regular part of your design process, educational programme or research activity?
yes *no* *dont know*
3. If NO, are you, your company or institution considering using 3D computing as a regular part of your design process, educational programme or research activity?
yes *no* *dont know*
4. If YES: Please identify the 3D software you use on a regular basis

Having had a chance to study the map...

5. Do you think that the map has any relevance to the everyday practice of industrial design, in terms of the choices that designers have to make with respect to the tools that they use?
comments *yes* *no* *dont know*
6. Do you think the map is a relevant method of presenting research findings to a wider audience, i.e. professional designers?
comments *yes* *no* *dont know*
7. Can you imagine any circumstance in which such a map might be of use to you?
comments *yes* *no* *dont know*

If YES or DONT KNOW please go on to Question 8. If NO, please go on to Question 10

8. Can you envisage using the map in any of the following contexts? (please tick all that apply):

<i>commercial design project</i> <input type="checkbox"/>	<input style="width: 50px; height: 15px;" type="text"/>	<i>academic design project</i> <input type="checkbox"/>	<input style="width: 50px; height: 15px;" type="text"/>
<i>company design methods review</i> <input type="checkbox"/>	<input style="width: 50px; height: 15px;" type="text"/>	<i>personal methods review</i> <input type="checkbox"/>	<input style="width: 50px; height: 15px;" type="text"/>
<i>company research programme</i> <input type="checkbox"/>	<input style="width: 50px; height: 15px;" type="text"/>	<i>personal research programme</i> <input type="checkbox"/>	<input style="width: 50px; height: 15px;" type="text"/>
<i>personal interest</i> <input type="checkbox"/>	<input style="width: 50px; height: 15px;" type="text"/>	<i>teaching purposes</i> <input type="checkbox"/>	<input style="width: 50px; height: 15px;" type="text"/>
<i>other</i> <input type="checkbox"/>	<input style="width: 100%; height: 15px;" type="text"/>		<input style="width: 50px; height: 15px;" type="text"/>
9. If you have ticked any of the above, can you indicate for each where or how you might envisage using the map with these contexts. Please put the appropriate letter(s) in the box next to the tick. Please select from the following & use as few or as many letters as is appropriate.
A. at the beginning of a project (before the real process of design has started).
B. when you have a problem (as a point of reference)
C. as a checkpoint (to see how your process relates to/differs from map)
D. after the project (to see how your process relates to/differs from map)
E. other. please comment
10. Were there areas of the model with which you strongly agree / disagree?
yes, please identify *no* *dont know*
11. Were there characteristics statements with which you strongly agreed / disagreed?
yes, please identify *no* *dont know*
12. Is there anything you would like to see added or removed from the map?
yes, please identify *no* *dont know*
13. Out of necessity, certain generalisations have been made and terminologies adopted, did you find any of these terminologies inappropriate? If so, please indicate which and why.
yes, please identify *no* *dont know*
14. How easy / difficult did you find it to navigate the map?
very easy *easy* *neither easy or difficult* *difficult* *very difficult*
15. Any other comments?

Fig. 67. Questionnaire for Heuristic Map peer review feedback

2.5.2 Questionnaire responses

10 questionnaire responses were received. A selection, presented in chronological order, is included here. The formatting has been adapted from email and therefore includes only the questions that the reviewer has responded to.

Respondent Sample 1

Date: Sun, 06 Aug 2000 17:20:15
From: Wim Gilles: wgilles@ccs.carleton.ca
Organization: Carleton University

1. Please indicate your area of expertise

A: *(industrial, product) designer C: educator (Emeritus)*

2. Do you, your company or institution use 3D computing as a regular part of your design process, educational programme or research activity?

A: *yes.*

4. If YES: Please identify the 3D software you use on a regular basis:

Pro Engineer

5. Do you think that the map has any relevance to the everyday practice of industrial design, in terms of the choices that designers have to make with respect to the tools that they use?

A: *yes, but very little*

COMMENTS: *for today's "normally" (=well) educated industrial designer the choices and their advantages and disadvantages are well known. They may use your map perhaps for "extra external" communication e.g. to a prospective client. In that case it should be a hard copy, to be discussed in person at a meeting and then left with the client. For internal communication? Perhaps with a graduate from an Art & Design school who is under the impression of knowing something about industrial design, but who in reality can only make pretty pictures.*

6. Do you think the map is a relevant method of presenting research findings to a wider audience, i.e. professional designers?

C: *don't know*

COMMENTS: *I don't know what research findings you have in mind.*

7. Can you imagine any circumstance in which such a map might be of use to you?

A: *yes.*

COMMENTS: *as an illustration in an article or in a chapter of the book for which I recently completed a second version of text. Also as an illustration in a lecture about CAID to First Year students*

8. Can you envisage using the map in any of the following contexts?

G: *Personal interest.*

H: *Teaching purposes.*

I: *Other: publications*

9. If you have selected any of the above, can you indicate for each where or how you might envisage using the map within these contexts? Please put the appropriate number(s) next to the selection. Please select from the following & use as few or as many numbers as is appropriate.

(i): *At the beginning of a project (before the real process of design has started),*

10. Were there areas of the model with which you strongly agree / disagree?

B: *No.*

11. Were there characteristics statements with which you strongly agreed / disagreed?

B: *No.*

12. Is there anything you would like to see added or removed from the map?

A: *Yes: There is no mention of the "digital data base" as the heart of the necessary qualitative and quantitative definition and delineation of a newly designed product. Such a digital database should be the base also for the communication of "form," internally, e.g. for renderings, stereo lithographically made models, prototypes and production moulds of parts. Geometric problems (research needed!) galore to produce proper form databases. (See my book "Form Organization, New Design Procedures for Numerical Control," Butterworth Heinemann, Oxford, 1991)*

13. Out of necessity, certain generalisations have been made and terminologies adopted, did you find any of these terminologies inappropriate? If so, please indicate which and why.

No.

14. How easy / difficult did you find it to navigate the map?

C: *Neither easy (n) or difficult. However, why don't you start with showing the whole map straight away in the beginning?*

In general: Why do you call your map Heuristic? I don't see any "heuristic" in it. Is it not just an illustration or overview of a situation?

Respondent Sample 2

Date: Mon, 7 Aug 2000 16:35:23 +0100

From: Steve Garner: S.W.Garner@open.ac.uk

Organisation: Open University

1. Please indicate your area of expertise

C: *educator*. D: *researcher*

2. Do you, your company or institution use 3D computing as a regular part of your design process, educational programme or research activity?

A: *yes*

4. If YES: Please identify the 3D software you use on a regular basis:

Varies enormously within the University but AutoCAD and 3Dstudio would be the main ones in my area

5. Do you think that the map has any relevance to the everyday practice of industrial design, in terms of the choices that designers have to make with respect to the tools that they use?

COMMENTS: Probably not in professional practice but certainly has possibilities in design education. I think most designers will have developed a preference for certain modelling tools. They will know what works for them in their context and will be sufficiently familiar with other modelling tools not to bother looking up when or where to use say, sketching or prototyping. There is a market for the map if it can be regularly updated so that the functionality of new modelling tools (CAD, rapid prototyping, new materials etc) can be demonstrated. This would be particularly useful where modelling tools have unexpected applications (for example, sketching via rapid prototyping). In such cases the examples would be very helpful and could be extended via a 'gallery' of further relevant examples.

6. Do you think the map is a relevant method of presenting research findings to a wider audience, i.e. professional designers?

COMMENTS: I view the map as a presentation of research material but not research findings. I think it could be developed to include research findings. Perhaps each page could contain comments from the respondents of your questionnaire? Research findings also suggest some form of commentary and a construction placed on the evidence by you. We need to be told what you believe you have achieved - so that we can disagree with you! (or, of course, wholeheartedly agree) Either way, constructing the research findings is your job - not the viewers. They will supply feedback, opinion and suggestions but the responsibility (and the PhD) will be yours. Your abstract is very helpful but is qualitatively different to the content of the map.

7. Can you imagine any circumstance in which such a map might be of use to you?

COMMENTS: I teach design to undergraduates and one of the broader concepts concerns the functionality and value of modelling within designing. Your map would provide an excellent contribution to such teaching. At first I thought there was too

much repetition in your map. However, after a while I changed my mind. There are sound advantages to presenting students with a resource that reinforces the multi functionality of the various modelling types. Personally, I'm interested in the functionality of sketching throughout the design process. Furthermore, I like your map because you begin to suggest that design progression doesn't depend on a formulaic or linear application of a set modelling tools. Some people develop concepts via engineering drawings, others make sketch constructions in foam, other sketch with a pencil.

8. Can you envisage using the map in any of the following contexts?

F: *Personal research programme.*

G: *Personal interest.*

H: *Teaching purposes.*

9. If you have selected any of the above, can you indicate for each where or how you might envisage using the map within these contexts? Please put the appropriate number(s) next to the selection. Please select from the following & use as few or as many numbers as is appropriate.

(i): *At the beginning of a project (before the real process of design has started)*

(ii): *When you have a problem (as a point of reference)*

(iii): *As a checkpoint (to see how your process relates to/differs from map)*

(iv): *After the project (to see how your process relates to/differs from map)*

Probably all of these.

10. Were there areas of the model with which you strongly agree / disagree?

I think you need to review the engineering drawing content. There are many different type of drawing, each with a distinct purpose. General arrangement drawings have a different function to drawings showing tolerances. This may seem pedantic but they are probably as different as say, sketching and rendering.

11. Were there characteristics statements with which you strongly agreed / disagreed?

B: *No*

12. Is there anything you would like to see added or removed from the map?

See comments above.

13. Out of necessity, certain generalisations have been made and terminologies adopted, did you find any of these terminologies inappropriate? If so, please indicate which and why.

I think your research is intended to enhance a designers modelling capability through the use of new computer-based resources. This might be its most marketable aspect. Designers have always used models to help them design including drawings, images and constructions. Prototypes are models, the thoughts in their heads are models - perhaps even the words they use are models? They are using models to explore, understand, create and explain. What your map begins to do is to suggest there might be more efficient modelling tools available for modern practice. It also, interestingly,

begins to substantiate the value of some older modelling tools like the humble pen or pencil!

14. How easy / difficult did you find it to navigate the map?

Neither easy nor difficult.

Respondent Sample 3

Date: Thu, 10 Aug 2000 19:09:40 +1200

From: Lyn Bishop: bishop@kea.lincoln.ac.nz

Organization: Lincoln University

1. Please indicate your area of expertise

A: designer. B: design manager. C: educator.

2. Do you, your company or institution use 3D computing as a regular part of your design process, educational programme or research activity?

A: yes

4. If YES: Please identify the 3D software you use on a regular basis:

AutoCAD and 3-d viz, Photoshop, arcview, arcexplorer, sage

5. Do you think that the map has any relevance to the everyday practice of industrial design, in terms of the choices that designers have to make with respect to the tools that they use?

A: Yes

COMMENTS: however more applicable to those just starting out and beginning an understanding of design tools, etc I think established designers may pick and choose tools a bit more. [i.e. ways of representing]. It could also be that in manufacturing the designer is locked into a production process and documented q.a. system that hinders flexibility of tool selection. In my field [landscape architecture, this includes design of individual components such as handles, water features, seating, screens, garden products etc.] Practitioners are often working in small groups, or individually, where there is a reasonable amount of dialogue between the team members, and flexibility of tools and approach often driven more by the project budget, and whether there is a need to interface project data with other members of a cross-disciplinary team via e-mail, or website hyperlinks.

6. Do you think the map is a relevant method of presenting research findings to a wider audience, i.e. professional designers?

A: yes.

COMMENTS: *yes, very useful, especially good way of explaining to students, as a model of practice.*

7. Can you imagine any circumstance in which such a map might be of use to you?

A: *yes, see comment above.*

8. Can you envisage using the map in any of the following contexts?

A: *Commercial design project. YES*

B: *Academic design project. YES*

C: *Company design methods review. YES*

D: *Personal methods review. YES*

E: *Company research programme. YES*

F: *Personal research programme. YES*

G: *Personal interest. YES*

H: *Teaching purposes. YES*

9. If you have selected any of the above, can you indicate for each where or how you might envisage using the map within these contexts? Please put the appropriate number(s) next to the selection. Please select from the following & use as few or as many numbers as is appropriate.

(i): At the beginning of a project (before the real process of design has started),

(ii): When you have a problem (as a point of reference)

(iii): As a checkpoint (to see how your process relates to/differs from map)

(iv): After the project (to see how your process relates to/differs from map)

(vi): Other, please comment

All of these situations

10. Were there areas of the model with which you strongly agree / disagree?

B: *No.*

11. Were there characteristics statements with which you strongly agreed / disagreed?

B: *No*

12. Is there anything you would like to see added or removed from the map?

B: *No.*

13. Out of necessity, certain generalisations have been made and terminologies adopted, did you find any of these terminologies inappropriate? If so, please indicate which and why.

B: *No.*

14. How easy / difficult did you find it to navigate the map?

C: *Neither easy nor difficult.*

Respondent Sample 4

Date: Mon, 14 Aug 2000 22:14:25 +0100

From: Kevin McCullagh <kevin.mc@pobox.com>

Organisation: Seymour Powell

1. Please indicate your area of expertise

A: *designer*

2. Do you, your company or institution use 3D computing as a regular part of your design process, educational programme or research activity?

A: *yes.*

4. If YES: Please identify the 3D software you use on a regular basis:

- *SDRC*

- *ProEngineer*

- *CDRS*

- *Solidworks*

5. Do you think that the map has any relevance to the everyday practice of industrial design, in terms of the choices that designers have to make with respect to the tools that they use?

B: *no.*

COMMENTS: *I think it's really useful for students and I think practitioners would find it interesting, but most practitioners spend all their time on the machines and learn in a very hands on way*

6. Do you think the map is a relevant method of presenting research findings to a wider audience, i.e. professional designers?

A: *yes.*

COMMENTS: *It's the only way!*

7. Can you imagine any circumstance in which such a map might be of use to you?

B: *no.*

COMMENTS: *I'm not involved with 3D CAD in our studio, as it is only used in more downstream activities, my contact with a project tends to drop off after the concept design stage*

10. Were there areas of the model with which you strongly agree / disagree?

C: *Don't know. I didn't read every page, but the stuff I did I agreed with!*

11. Were there characteristics statements with which you strongly agreed / disagreed?

B: *No.*

12. Is there anything you would like to see added or removed from the map?

B: *No.*

13. Out of necessity, certain generalisations have been made and terminologies adopted, did you find any of these terminologies inappropriate? If so, please indicate which and why.

A: *Yes (please identify).*

Call me forgetful, but I've forgotten what 'Heuristic' means, should it be explained or maybe there's another way of saying it? I wasn't sure what 'Comm. ex. external' meant - 'unconstrained and constrained' models could do with a wee explanation (maybe a hotlink to a glossary or a new window)

14. How easy / difficult did you find it to navigate the map?

B: *Easy.*

15. Any other comments?

- it might be quite nice to provide a brief 'back story' for each project, so users can orientated themselves with the brief..... You have done that, its in help

- initially confused by green and pink, thought that pink meant digital and green non-digital, then realised that they symbolised different projects

- there are lots of cool digital integrated techniques that don't involve 3D. It might be worth adding a rider in your intro to make it clear that 'digitally integrated' does not equate with '3D'

2.6 Distribution Maps

The first and most relevant of the distribution maps involved a matrix of the 'what' & 'why' variables (Fig. 68), illustrating which forms of media were used by certain reasons for use, regardless of the influence of the timeline. An adaptation of this data array technique was later employed in the full cross case analysis. There then followed two further maps, the first (Fig. 69) mapping the communication variable 'who' against the media variable 'what' and establishing some general reasons for using certain forms of media for certain types of communication, independent of the time line. The second distribution map (Fig. 70) looked at the relationship between the media types and the timeline attributes.

Distribution: <i>what & why</i> (detail)	words	sketch	draw	s. model	c. model	render	2D spec.	2D spec.	raytrace	app mod	3D spec.	prototype	animation	rapid prot
Think quickly	●	●												
Record ideas	●	●												
Annotate	●													
Report	●													
Generate ideas		●												
Give idea form		●												
Develop / refine idea		●	●	●										
Develop / refine detail			●											
Develop / establish 3D form			●	●	●	●			●					
Proportions / scale				●			●	●						
Initial ergonomics				●										
Develop / est. 3D geometry				●	●									
Component interaction				●	●									
Initial mech / functional				●	●		●							
Use to test				●	●									
Assembly				●	●		●							
Entry level specification					●									
Costings					●		●	●			●			
Colour proposals						●			●					
Sell concept						●			●	●				
Reaction to environment									●	●			●	
Finish / materials									●	●	●		●	
Integrate graphics									●				●	
Capture ess / emot / charac.						●							●	
Relationship comps in use													●	
Simulate reality													●	
Dimension / accuracy							●	●			●		●	
Finite 3D form										●	●			●
Emotional response										●	●	●		
Client confidence										●	●	●	●	
Virtual creation part										●	●	●	●	
Qualify fit / interaction											●			●
Market / consumer testing										●		●		●
Physical model - feel/ touch / hold.												●		●
Clarify all iss; abs. conf. part												●		●
Functionality in use												●		●

Fig. 68. Distribution map cross-referencing reasons for use with media types. Digital media are shown by red, traditional by green.

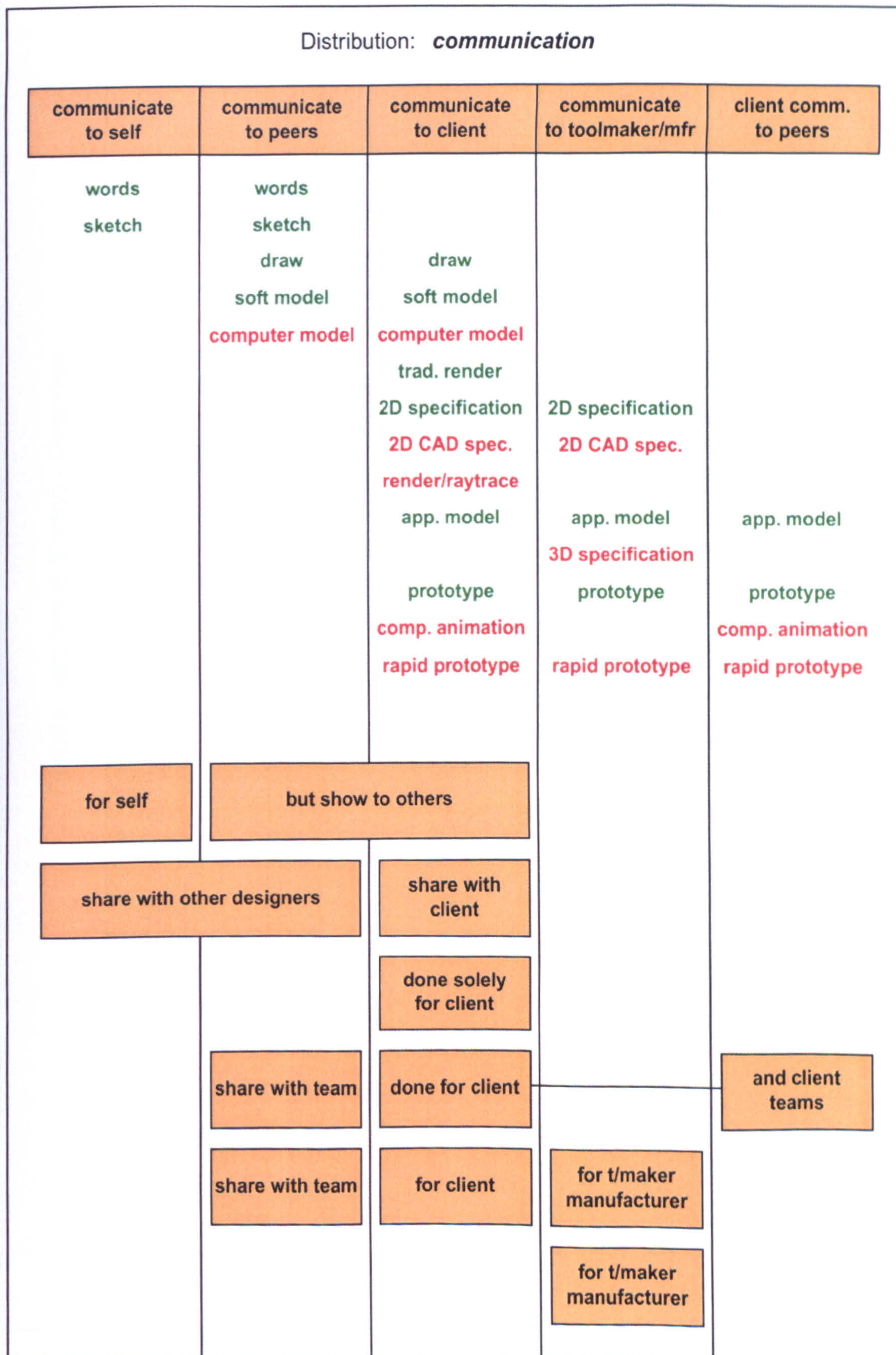

Fig. 69. Distribution map illustrating the relationship between communication and media types.

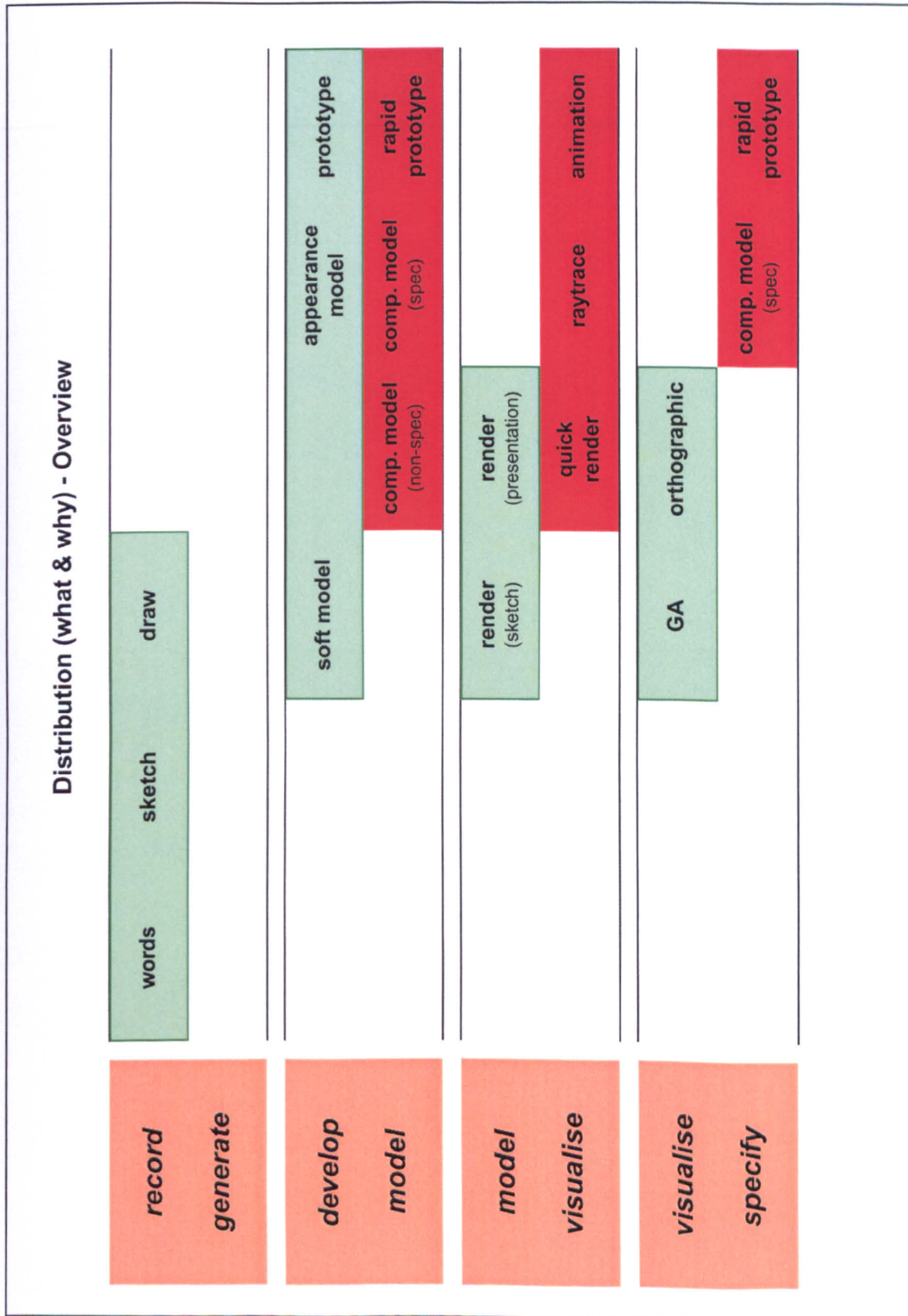

Fig. 70. Distribution map illustrating the relationship between the media types and timeline attributes.

Appendix 3: Published Material

3.0 PUBLISHED MATERIAL

A number of refereed papers and seminars were presented during the research programme; the key ones are listed following:

A Heuristic Model for Digitally Integrated Design, a paper published in Co-Design Journal, 07.08.09, 1996.

What have we learnt so far about using computers? A paper presented at 'Networking Design', Design for Industry Course Conference, UNN, March 21, 1996.

Digital Integration & Designer Tactics. A paper presented at the CADE Postgraduate Conference, Coventry University, March 26, 1996.

The Integration of the Digital in the Design Process. A paper presented at 'Multi-Viewpoint: Shaping the Human Computer Interface', DRS Seminar, UNN, July 2, 1998.

Two of the papers are included in the following sections.

3.1 A Heuristic Model for Digitally Integrated Design

Published in Co-Design: s3. 07. 04:05:06. 96: 2

This paper is based on an investigation into the impact that digital technologies are having on the everyday working practices of the industrial designer, specifically in terms of its use as a tool for communication and decision-making. It discusses the creation of a, 'heuristic model for a digitally integrated design process' through the undertaking of a number of commercial design projects. This study harnesses the principles of an Action Research methodology and comprises reflection on three years work within the Centre for Industrial Design, a research led design consultancy. As such this work has been developed by practitioners, for practitioners, working within a

reflective research framework (1). The resultant model represents the integration of digital technologies with traditional processes for designing. Set within the context of industrial design consultancy practice, it seeks to establish the points at which, the means by, and the reasons why, digital technologies might be used within the design process.

Introduction

From the corporate to the domestic environment, there is no doubt that the ‘technology revolution’ is having a real effect on our lives (2). This is particularly the case in industrial design, where the demand on designers follows in the wake of advances in technologies for engineering and manufacturing. Consultants are now required to provide a more comprehensive design and development service, resulting in a greater pressure on the technological capabilities of industrial design practice (3). Ranging in complexity from basic 2D CAD through to VRML (4), digital technologies have had, and will continue to have, a lasting impact on industrial design practice.

Design and Communication

Much of the design process is esoteric and complex. Designers conventionally employ a broad range of media to assist them in carrying out the process. These media assist designers in their creative process by externalising a design ‘thought’ and making it tangible and therefore open to review, either by themselves or others. The externalisation of what is seen by ‘the mind’s eye’, as described by Ferguson (5), and Cross (6), are acts of communication:

“Both the engineer and the artist start with a blank page. Each will transfer to it the vision in his mind’s eye.”

“This ability to design depends partly on being able to visualise something internally, in the ‘mind’s eye’, but perhaps it depends even more on being able to make external visualisations”

Communication is key to the design process in that it acts as a facilitator for the creative act. It is assumed that effective decision-making is intrinsic to an effective design process, however if a design 'thought' is inappropriately communicated then design decisions may be made to the detriment of the future development of that design. The management of the media is therefore critical - as the inappropriate use of media can cause problems whether communicating internally within the design team or externally to clients. But which form of communication is appropriate and under what circumstances? This leads us to ask:

- Is it appropriate to use digital technology to enable to process of designing?
- Is it appropriate to use digital technology to communicate the design?

Having considered these questions relative to the same questions for traditional technology, this paper describes a model for Digitally Integrated Design (DID). DID is seen as the incorporation of activities such as digital modelling, animation and rapid prototyping into the traditional design process. The model is represented in the form of a heuristic map, proposed to be used by practising designers to aid in their understanding of, and involvement in, DID practice. The map charts a potential route for this integration, defining the paths of activity and integration for both traditional and digital forms of communication, asking three essential questions of appropriateness: what to use?, where to use it?, and why? The map seeks to reflect actual practice and is inherently heuristic. It provides a logical framework within which the effects of integrating digital technology into the industrial design process can be assessed.

Another model for design?

More design research is being carried out than ever before (7). The use of technology has become a major issue with researchers. They have concerned themselves with issues such as the nature of the effect of digital technology on the actual creative process (8), looking at factors affecting the integration of 3D CAD (9), and the response of design practice to the introduction of computing technologies (10).

However, it would appear that little work has been done concerning the role of digital technology in terms of its effectiveness as a communication tool. In particular its effect on how industrial designers communicate both internally and externally, and consequently its impact upon the tools and techniques which designers use.

Case studies

Three case studies underpin the findings of the research, chosen for three reasons, they represent:

- the predominant type of work carried out by the Centre this reflects the context in which the research has been carried out;
- three principal areas of industrial design practice, i.e. conceptual design, customised design for batch production, design for mass production;
- the utilisation of a wide range of both traditional and digital processes.

Case study 1. Procter & Gamble - Soulagil.

(Fig. 71 & Fig. 72)

A conceptual project to investigate the possibility of achieving a 30 per cent reduction in the manufacturing pack cost of a retail pharmaceutical throat spray.

The key feature of this case study was the variety of approaches used through which the client could assess the various design proposals that were presented. The most effective of these was the use of 3D fully rendered digital images in conjunction with white models (11). This was particularly appropriate for a hand held product which incorporates a high level of surface graphics, the technique allowed both individual and simultaneous visual and ergonomic assessment.

media employed

Traditional: words, sketch, draw, soft model, 2D spec (GA), render.

Digital: computer model, ray trace, 2D spec.

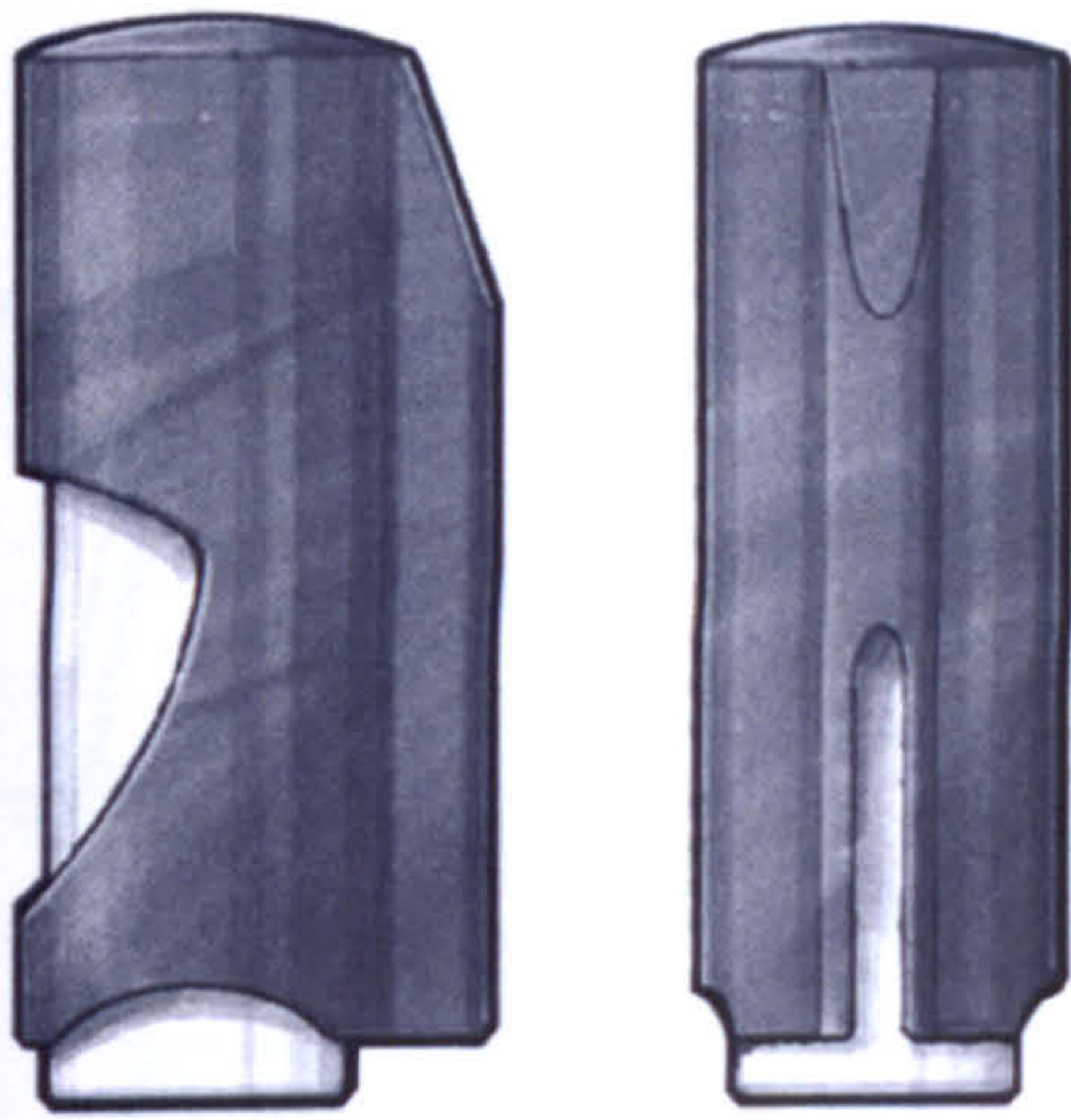

Fig. 71. Hand rendering of 'Soulagil' Concept



Fig. 72. Final computer visualisation

Case study 2. Department of Health, Scotland - Medis

(Fig. 73 & Fig. 74)

The project entailed the design and production of five public access terminals through which patients can access their personal medical history.

The activity within this project mainly took place in the traditional domain. However computers were effectively employed as a validation and specification tool. The key means of communication was full scale soft modelling; this was imperative in order to evaluate all issues relating to form, ergonomics, detailing and functionality at a human scale. The production of fully working prototypes allowed for 'in-situ' user feedback.

media employed

Traditional: words, sketch, draw, soft model, 2D spec (GA), prototype.

Digital: computer model, render, 3D spec.



Fig. 73. Initial sketches of Medis concept

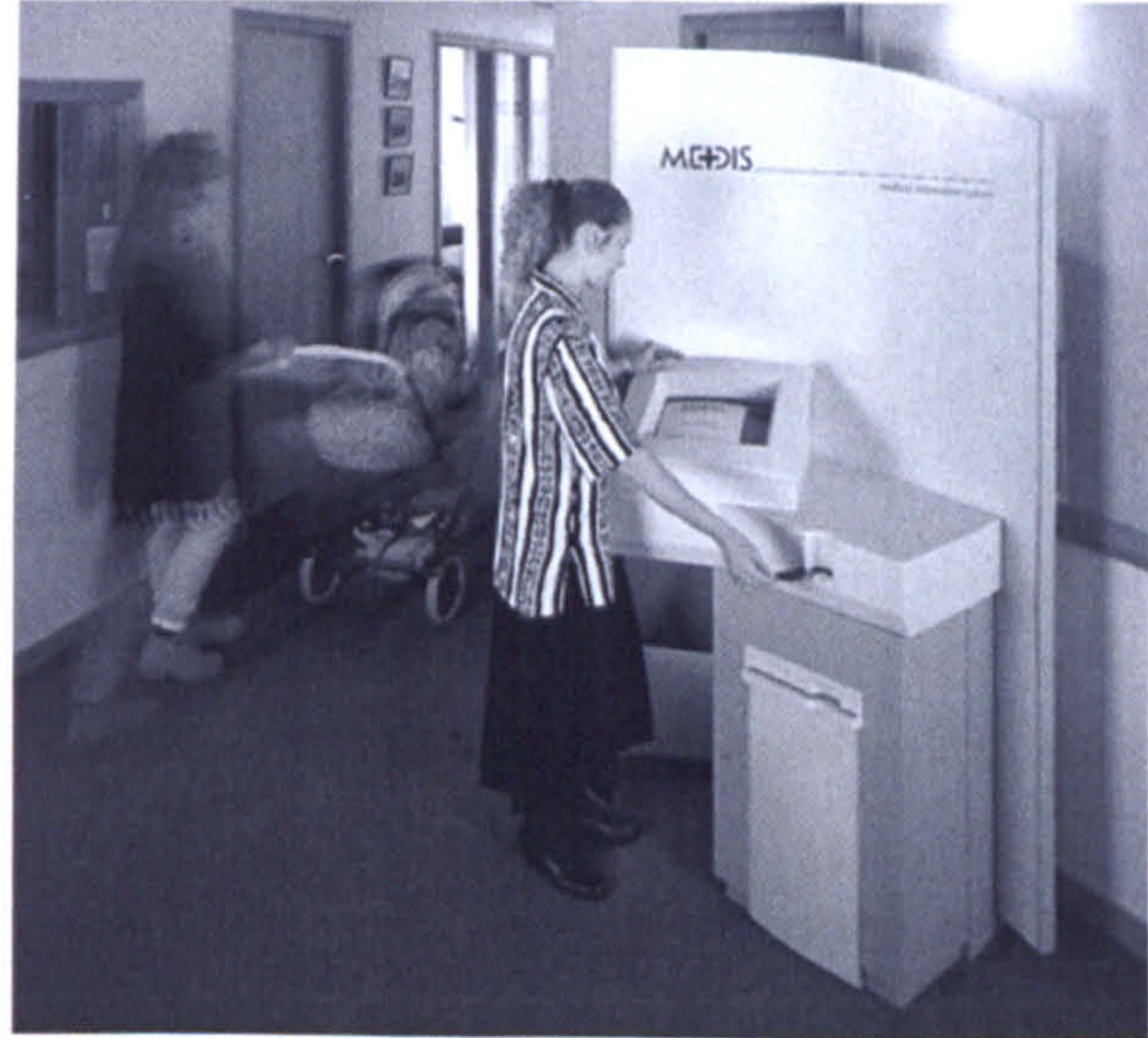

Fig. 74. Final Medis prototype

Case study 3. Multinational Pharmaceutical - Bi-liquid mixing system

(Fig. 75 & Fig. 76)

The project entailed the design of a mass produced bi-liquid container within which the liquids must be kept separate and inaccessible to the user until mixed. The mixing system must be fail-safe.

This project could not have been realised without the use of computing technology. Although the operation of the product is simple to the end user, in order to design the complex functionality, the use of computers was essential for validation and communication. Sketching and drawing could only reach a certain stage of development. Traditional modelling processes would have been not only virtually impossible considering the complexity of the parts, but extremely expensive and time consuming. The use of rapid prototyping enabled the evaluation of the concept within 24 hours of commissioning the part.

media employed

Traditional: words, sketch, draw, 2D spec (GA).

Digital: computer model, render/ray trace, animation, 2D spec., 3D spec., rapid prototype.

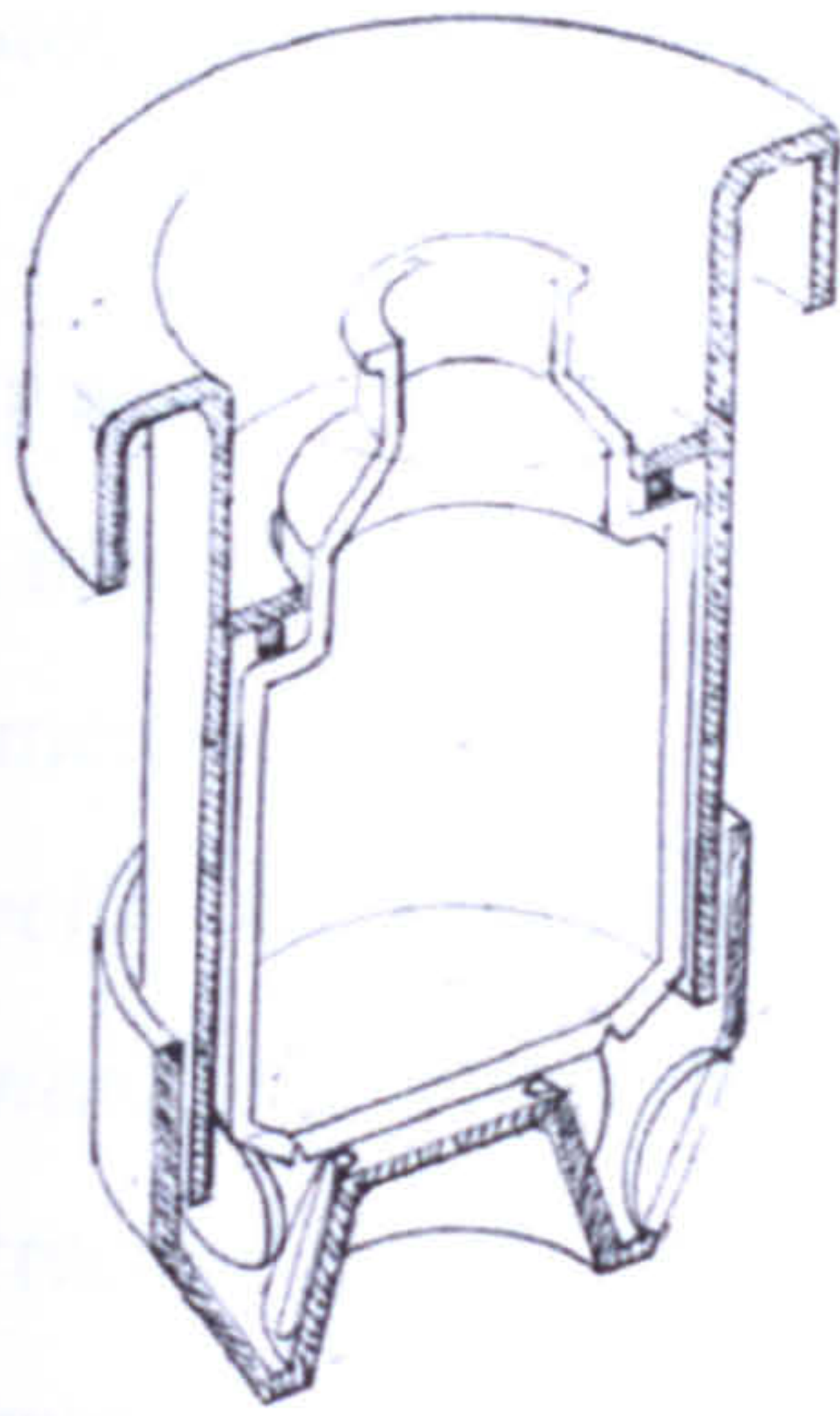

Fig. 75. Drawing of initial Bi-Liquid Mixing System concept

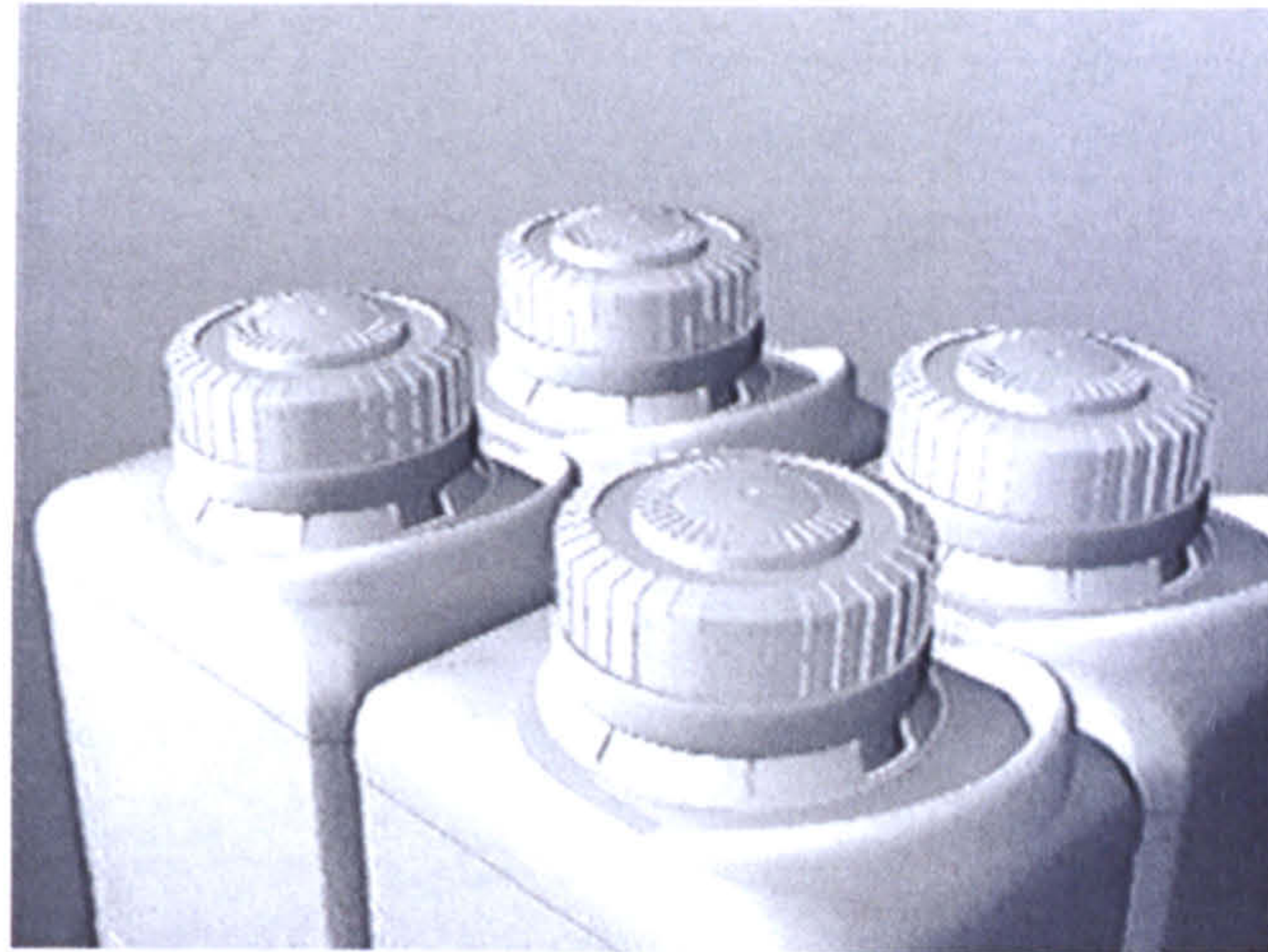

Fig. 76. Still from Bi-Liquid Mixing System animation

Drawing the map

Taking the findings of each case study, the use of various forms of media was categorised and ordered against three questions:

where to use the media?

The principal zones of the map were identified in terms of the Centres' four most common stages as quoted to clients:

- Stage 1 - Pre-Design,
- Stage 2 - Concept Generation
- Stage 3 - Design Development
- Stage 4 - Specification

what to use?

An identification of the media commonly used as an aid to the design process. For clarity these are split into subsets of digital and traditional.

Traditional: Words, sketch, draw, soft model, render, 2D spec., appearance model, prototype

Digital: Computer model, render/ray trace, animation, 2D spec., 3D spec., rapid prototype.

why use it?

An identification of reasons for using these forms of media, this comprises three elements:

Specific: the reasons for using a particular form of media, such as 'sketch'.

General: the reasons for using a range of media within each stage of the process, such as 'record'.

Communication: reasons for communication take two forms: 'Direct' and 'Indirect'.

At this point the reasons for using them are identified independently of the points at which they are used. Fig. 77 illustrates the relationship between all of these factors; the map was formulated in the following way:

- Identify the zones of the map, 'where'.
- Relate the media, (what) to, 'where'.
- Relate specific reasons, (why) to 'what'.
- Relate reasons for communicating (why) to 'what'.
- Relate general reasons, (why) to 'what'.

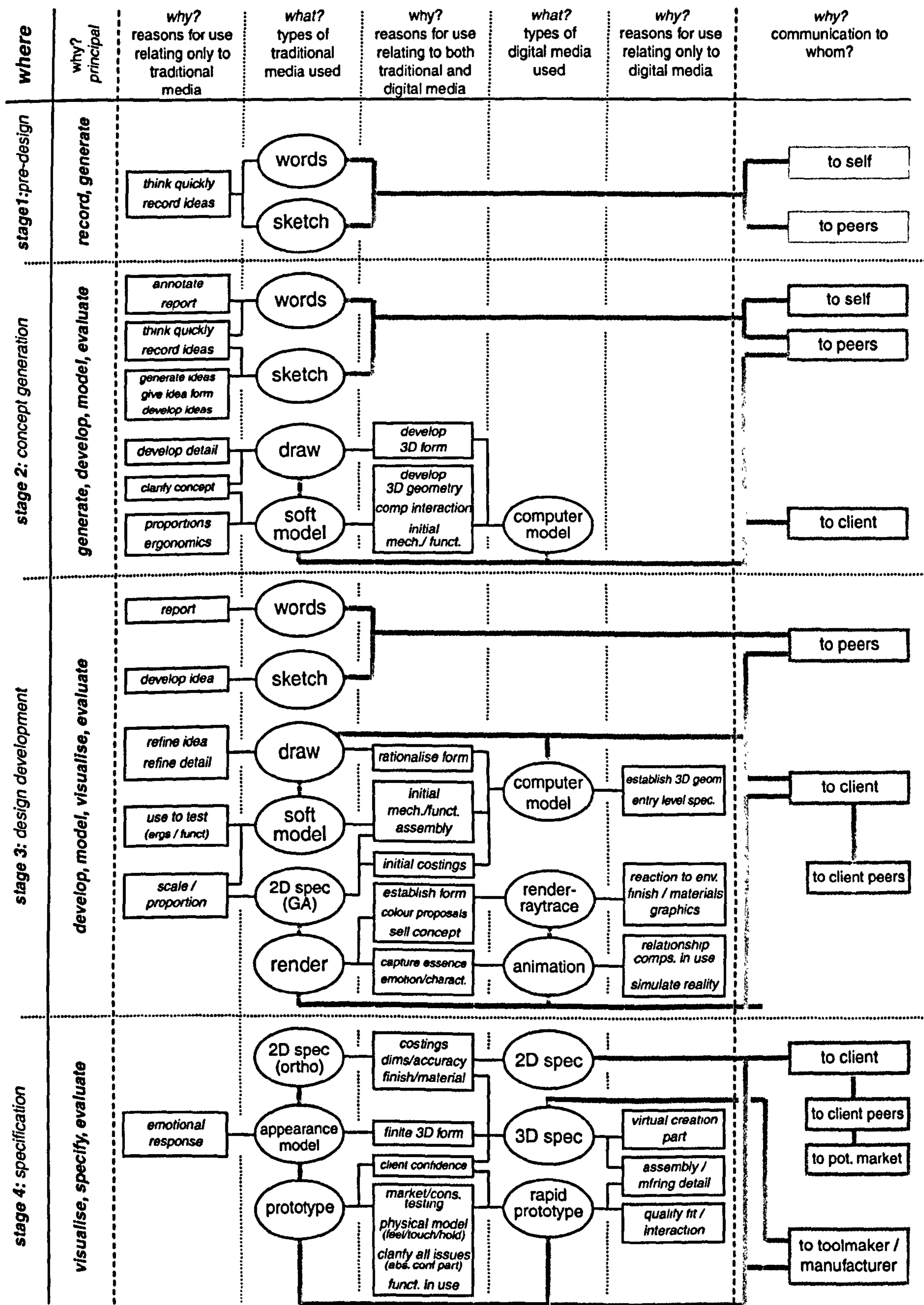

Fig. 77. Integration model

Studying the map

Analysis of the model within the individual stages showed the following:

Pre-Design: No reasons appear to be evident in supporting the use of digital technology.

Concept Generation: No reasons appear to be evident to support the use of digital technology for its own sake.

Design Development: There appear to be an equivalent number of reasons for using either form of media.

Specification: The balance moves in favour of digital media.

Analysis of the process of building the map, combined with the findings of the case studies, allows us to make a number of statements regarding the strengths and weaknesses of digital technology.

benefits of digital technology

Using digital technology appears to benefit design activities such as:

Design Validation: providing the ability to interrogate all aspects of the digital model before it is built.

Design Editing: Changing colour or materials or making detail modifications.

Specification: from enabling the generation of 3D files for tool making, to the production of 2D plots.

Prototyping: the production of accurate working models from computer data.

Communication: from interactive on screen computer models providing focus for discussion with peers, to the use of photo-realistic imagery and animation to convince a potential marketplace.

weaknesses of digital technology

Using digital technology has a number of weaknesses, it can be:

Restrictive: lack of user skill or flexibility in modelling tools can lead to a loss of design quality where the computer drives the design, rather than vice versa.

Time taken to build: building computer models is time consuming, it is necessary to identify whether or not their use is appropriate.

Integrity of model: is the model built in such a way so as to allow future flexibility?

Lack of sensory feedback: one cannot touch, feel or hold the model.

Processing power: especially with areas such as animation, a lack of processing power can compromise what one can afford to communicate.

This led us to draw a number of conclusions:

- Computers are ideally suited to specific, well-defined tasks. It may be inappropriate to use as a blank sheet of paper, trying to ‘design’ on it.
- Digital technologies do not provide a panacea for design practice. The use of media is context specific, depending on the individual nature and demands of each design project.
- Digital technologies are better suited to the latter stages of the design process, when more parameters are in place and creativity is not so important (12).
- Digital technologies do not replace traditional media; instead they work together to provide a comprehensive design and communication resource.

Reflection on practice

In adopting action research principles (13) the research has endeavoured to maintain proximity with industrial design practice, this is achieved by completing the cycle of design, reflection and evaluation to inform further practice, thus allowing the creation of tools for practice, rather than abstract academic theories (14).

Conclusion

The Centre has found that whilst digital technologies do not provide a panacea for Industrial Design practice, their use can enable a substantial improvement in the effectiveness and efficiency of the design process, but only if managed in an appropriate manner. Computers cannot do everything and it is imperative that the level of their use is concurrent with the needs of each design project. The use of CAD as a

validation tool gives a greater confidence in the design as it allows more issues to be interrogated before commitment to manufacture is made, however if used inappropriately or too soon in the process, CAD can inhibit creativity as in the main it requires a both a significant level of user skill as well number of design parameters to be in place before it is attempted. A computer is a powerful tool, but its use does not turn a designer into a better designer, however it may enable that designer to make better design decisions. The Centre has found that computers are not the solution; they are merely part of a big picture in which the main criterion is retaining optimum design quality. As long as products are conceived by and produced by humans, industrial design will always be accountable to the end product and no amount of computing power can change that.

References

1. **Schon, D A.**, (1991), 'The reflective practitioner, how professionals think in action', Avebury.
2. **Rifkin, J.**, (1995), 'The end of work', Putnam, New York.
3. **Clipson, C.**, (1995) 'Redesigning design: some critical dimensions for research', Co-Design, 01/02/03.
4. **VRML: Virtual Reality Modelling Language.**
5. **Ferguson, E.**, (1992), 'Engineering and the Mind's Eye', MIT Press, Cambridge, p.23.
6. **Cross, N.**, (1994), 'Engineering design methods: strategies for product design', 2nd Ed., Wiley, Chichester, p.8.
7. **Cross, N.**, (1993) 'Science and Design Methodology: a review', Research in Engineering Design, Vol. 5, no. 2.
8. **Dijk, C G C van.** (1995) 'New insights in computer aided conceptual design', Design Studies, Vol. 16, No.1, p.62-80.
9. **McCullagh, K.** Current research project: 'To investigate the processes by which computer aided techniques are integrated into industrial design consultancy practice', University of Northumbria.

10. Rust, C. et al. (1993), 'The management of information technology in the professional practice of three dimensional design', Sheffield Hallam University, ISBN 0863393748.
11. **White Models:** models that accurately represent the design but have no colour or graphics applied.
12. Temple, S. (1994) 'Thought made visible - the value of sketching', Co.-Design, 10/11/12.
13. McNiff, J., (1988), 'Action research: principles and practice', McMillan, London.
14. Cooper, R, D. (1995) 'Setting a research framework', Co.-Design, 01/02/03.

3.2 Digital Integration & Designer Tactics

Abstract

This presentation/paper is based on the findings of a PhD programme entitled: 'Developing methods for the integration of digital modelling media into the industrial design process'. The study is principally involved with an investigation into the impact that digital technologies are having on the everyday working practices of the industrial designer, specifically in terms of its use as a tool for communication.

The paper discusses the development of a 'heuristic model for digitally integrated design' through the completion of a number of commercial design projects. The resultant model represents the integration of digital technologies with traditional methods for design development. Set within the context of industrial design consultancy practice, it seeks to establish the points at, the means by, and the reasons why communication might be used to effect decision-making.

Introduction

There is no doubt that the 'technology revolution' is having a distinct and apparent affect on our lives (1), from corporate business to the domestic environment. This is no more apparent than in the field of industrial design, where the demand on designers follows in the wake of advances in technologies for engineering and manufacturing.

Consultants are now required to provide a more comprehensive design and development service, resulting in a greater pressure on the technological capabilities of industrial design practice (2). Ranging in form from basic 2D CAD through to the complexities of VRML (3), digital technologies have had, and will continue to have, a lasting impact on industrial design practice.

Design and Communication

Much of the design process is esoteric and complex. Designers habitually employ a broad range of media to assist them in carrying out the process. These ‘tools’ assist designers in their creative process by externalising a design thought and making it tangible and therefore open to review, either by themselves or others. This externalisation as described by Cross (4), is an act of communication,

“This ability to design depends partly on being able to visualise something internally, in the ‘minds eye’, but perhaps it depends even more on being able to make external visualisations”

Communication is key to the design process in that it acts as a facilitator for the creative act. It is assumed that effective decision-making is intrinsic to an effective design process, however if a design thought is inappropriately communicated then design decisions may be made to the detriment of the future development of that design. The management of the media is therefore critical as the inappropriate use of media can cause problems whether communicating internally within the design team or externally to clients, but which form of communication is appropriate and under which circumstances?

This leads us to ask:

- Is it appropriate to use digital technology to develop the design?
- Is it appropriate to use digital technology to communicate the design?

Having considered these questions relative to the same questions for traditional technology, this paper presents a case for a model for Digitally Integrated Design

(DID). DID is seen as the incorporation of activities such as digital modelling, animation and rapid prototyping into the traditional design process. The model is represented in the form of a heuristic map, proposed to be used by practising designers to aid in their understanding of, and involvement in, digitally integrated design practice. The map charts a potential route for this integration, defining the paths of activity and integration for both traditional and digital forms of communication, asking three essential questions of appropriateness: what to use?, where to use it?, and why? The map is deliberately practical and inherently heuristic, it provides a logical framework within which the effects of integrating digital technology into the industrial design process can be assessed.

Another model for design?

Design research is becoming more prevalent (5) with the subject of technology an issue of major debate. Design researchers have begun to investigate the nature of the effect of digital technology on the actual creative process (6), looking at factors affecting the integration of 3D Computer Aided Design (CAD) (7), and the response of design practice to the introduction of computing technologies (8). However, it would appear that little work has been done concerning the role of digital technology in terms of its effectiveness as a communication tool. In particular its affect on how industrial designers communicate both internally and externally, and consequently its impact upon the tools and techniques which designers use.

Action Research

This study, based on the principles of an Action Research methodology, comprises reflection on three years work within the Centre for Industrial Design. As a research led design consultancy, the work presented in this context has been developed by practitioners, for practitioners, working within a reflective research framework (9). The work presented in this paper has been generated through the completion of commercial contracts and in particular three case studies carried out over the period, observations from other projects have also supported the research. The case studies have been chosen for three reasons, they represent:

- the predominant type of work carried out within the Centre and therefore the context upon which the research is based;
- the three principal areas of industrial design practice, i.e. conceptual design, customised design for batch production, design for mass production; and
- the utilisation of a wide range of both traditional and digital processes.

Case Study 1. Procter & Gamble - *Soulagil*. (Fig. 78 & Fig. 79)

A conceptual project to investigate the possibility of achieving a 30% reduction in the manufacturing pack cost of a retail pharmaceutical throat spray. Timescale - 6 months.

The key feature of this case study was the variety of methods used through which the client could effectively assess the various design proposals that were presented. The most effective of these was the use of 3D fully rendered images in conjunction with white models. This was particularly appropriate for a hand held product which incorporates a high level of surface graphics, the technique allowed both individual and simultaneous visual and ergonomic assessment.

Media employed

Traditional: words, sketch, draw, soft model, 2D spec (GA), render.

Digital: computer model, ray trace, 2D spec.

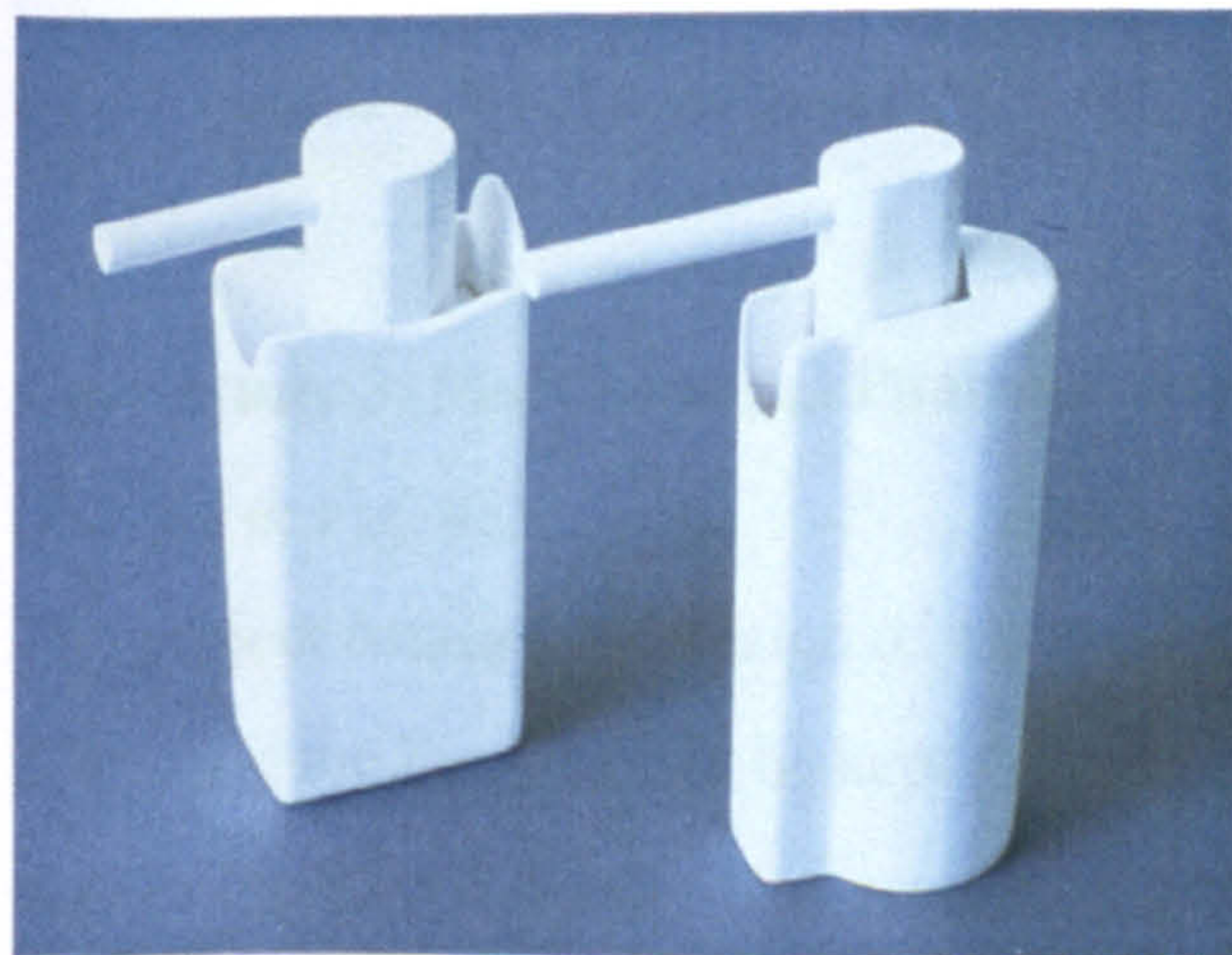

Fig. 78. White models of 'Soulagil' Concept



Fig. 79. Final computer visualisation

Case Study 2. Department of Health, Scotland - *Medis* (Fig. 80 & Fig. 81)

The design and production of five public access terminals through which patients can access their personal medical history. Timescale - 12 months

The activity within this project mainly took place in the traditional domain however computers were effectively employed as a validation and specification tool. The key method of communication was full scale soft modelling; this was imperative in order to evaluate all issues relating to form, ergonomics, detailing and functionality. The production of fully working prototypes allowed for in-situ user feedback.

Media employed

Traditional: words, sketch, draw, soft model, 2D spec (GA), prototype.

Digital: computer model, render, 3D spec.



Fig. 80. Full scale model of Medis concept



Fig. 81. Final Medis prototype

Case Study 3. Multinational Pharmaceutical - *Bi-liquid mixing system*

(Fig. 82 & Fig. 83)

The project entailed the design of a mass-produced bi-liquid container. Until the point of mixing the liquids must be kept separate and inaccessible to the user. The mixing system must be fail-safe. Timescale - 2 years

This project would never have reached the stage it has without the use of computing technology. To the end user the functionality of the product is simple, however in design terms, in order to comprehend the complex functionality, the use of computers to both validate and communicate was essential. Sketching and drawing could only reach a certain stage of development. Traditional modelling processes would have not only been almost impossible considering the complexity of the parts, but also extremely expensive and time consuming. Utilising rapid prototyping we were able to evaluate the concept within 24 hours of commissioning the part.

Media employed

Traditional: words, sketch, draw, 2D spec (GA).

Digital: computer model, render/ray trace, animation, 2D spec., 3D spec., rapid prototype.



Fig. 82. Computer visualisation of Bi-Liquid Mixing System concept



Fig. 83. Still from Bi-Liquid Mixing System animation

Drawing the map

Taking the findings of the case studies, the use of various forms of media within the context of each case study was categorised and ordered against three questions:

Where to use the media?: Based on an identification of the fundamental stages in a commercial design process, the principal zones of the map are identified in terms of the four main stages in the design process:

- Stage 1: *Pre-Design*
- Stage 2: *Concept Generation*
- Stage 3: *Design Development*
- Stage 4: *Specification*

What to use?: An identification of the media commonly used as an aid to the design process. For clarity these are split into subsets of digital and traditional.

- *Traditional:*

Words, sketch, draw, soft model, render, 2D spec., appearance model, prototype

- *Digital:*

Computer model, render/ray trace, animation, 2D spec., 3D spec., rapid prototype.

Why use it?: Identification of reasons for using these forms of media, comprises three elements:

- *Specific:* the reasons for using a particular form of media, such as ‘sketch’, e.g. Think quickly, Generate ideas, Record ideas, Develop ideas, Give an idea a form.
- *General:* the overall reasons for using a range of media within each stage of the process identified by ‘where’, e.g.: Record, Generate, Develop, Model, Visualise, Specify.
- *Communication:* reasons for communication can take two forms. ‘Direct’ i.e. communication to: self, peers, client, tool-maker, manufacturer, and ‘Indirect’ i.e. communication from: client to peers, client to potential marketplace.

At this point the reasons for using them are identified independently of the points at which they are used. Fig. 84 illustrates the relationship between all of these factors, the map was first formulated by myself in the following way and then validated by the Centre team.

The following actions were carried out to create the map:

- Identify the zones of the map, 'where'.
- Relate the media, (what) to, 'where'.
- Relate specific reasons, (why) to 'what'.
- Relate reasons for communicating (why) to 'what'.
- Relate general reasons, (why) to 'what'.

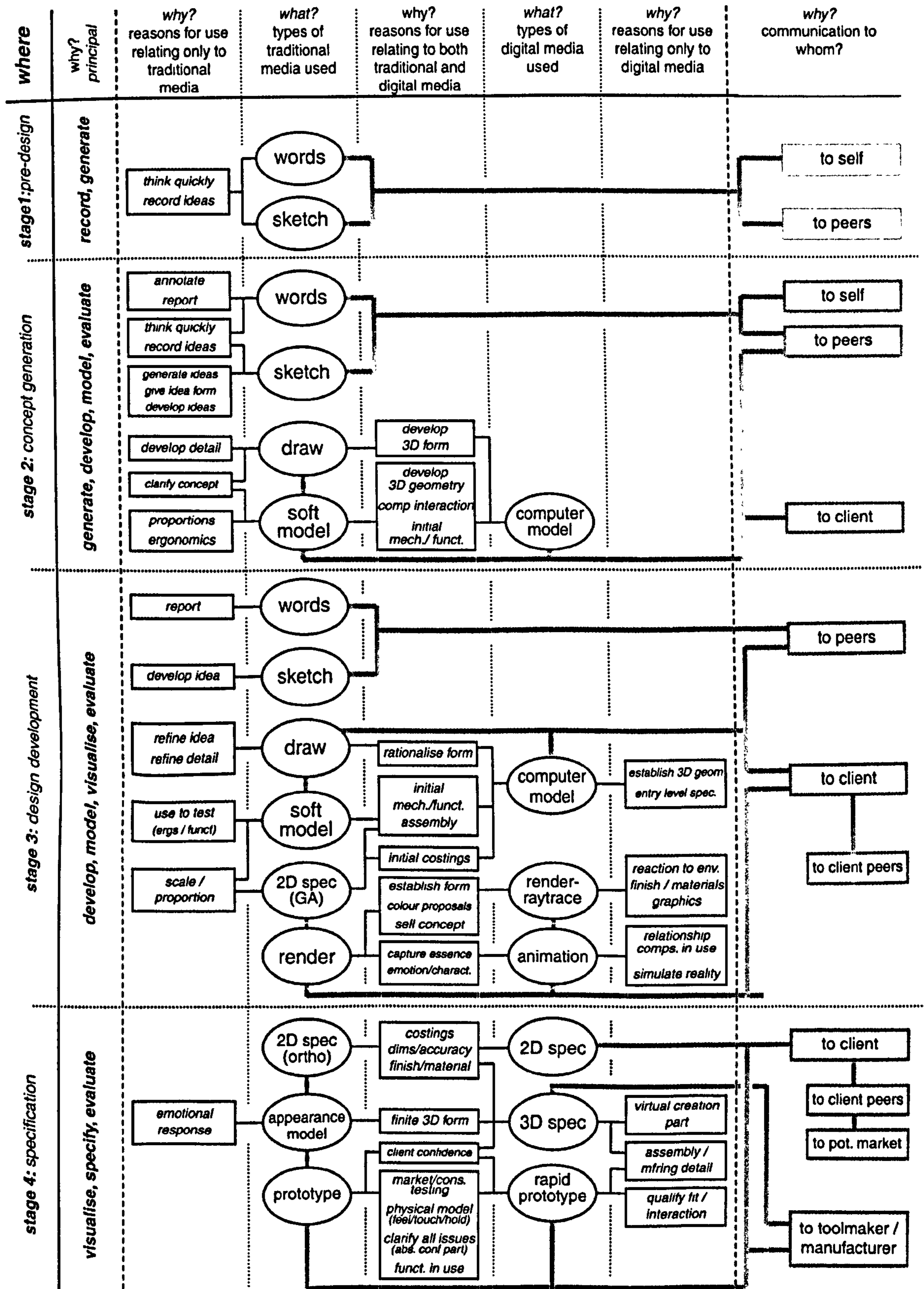

Fig. 84. Integration Map

Studying the map

Analysis of the model within the individual stages showed the following:

- *Pre-Design*: No reasons appear to be evident in supporting the use of digital technology.
- *Concept Generation*: No reasons appear to be evident to support the use of digital technology for its own sake.
- *Design Development*: There appear to be an equivalent number of reasons for using either form of media.
- *Specification*: the balance moves in favour of digital media.

Analysis of the building and resultant map, combined with the findings of the case studies, led me to draw a number of conclusions:

- Digital technologies do not provide a panacea for design practice.
- The use of media is context specific, i.e. it depends on the nature and demands of the individual research project.
- Digital technologies are better suited to the latter stages of the design process, when more parameters are in place and creativity is not so important (10).
- Digital technologies do not replace traditional media; instead they work together to provide a comprehensive design and communication resource.

Reflection on Practice

The Centre for Industrial Design in its position as a combined academic and commercial entity are fortunate in being able to suspend the economic argument of having to use computers because they are a substantial overhead. When this research programme was started three years ago we believed that computers were going to provide, if not a panacea, then a substantial improvement in the effectiveness and efficiency of industrial design practice. The Centre has learnt however that computers are not the solution; they are merely part of a big picture in which the main criteria is retaining maximum design quality. Computers are powerful tools, but their existence does not make us better designers. As long as products are conceived by and produced

by humans, industrial design will always be accountable to the end product and no amount of computing power will change that.

Adopting action research principles (11) we have endeavoured to remain true to industrial design practice whilst generating research findings which can be directly disseminated from a research to a practitioner base, allowing the creation of tools for practice, rather than abstract academic theories (12).

What next?

The model must be disseminated to the design profession for validation. To do that it must be represented in a form that can be both understood and utilised. This is an issue relating to the appropriateness of media in its own right and therefore is a manifestation of the argument presented in this paper.

As it stands the model only goes part way to understanding the role of traditional and digital media within the design process. Currently it only identifies the structural relationships between the major factors affecting the integration of digital technology.

There are many other factors which need to be considered, such as:

- ***Value:*** what is the value of each form of media at specific stages in the design process?
- ***Skill:*** what is the influence of user skill on the selection of media and what affect might this have on the design idea as it moves through the process?
- ***Pros and cons:*** why use one form of media over another? What are the advantages and disadvantages?
- ***Predecessors:*** certain forms of media are dependent on others having gone before, how does this affect the potential for integration?

References

1. **Rifkin, J.**, (1995), 'The end of work', Putnam, New York.
2. **Clipson, C.**, (1995) 'Redesigning design: some critical dimensions for research', Co-Design, 01/02/03.
3. **VRML: Virtual Reality Modelling Language.**
4. **Cross, N.**, (1994), 'Engineering design methods: strategies for product design', 2nd Ed., Wiley, Chichester, p.8.
5. **Cross, N.**, (1993) 'Science and Design Methodology: a review', Research in Engineering Design, Vol. 5, no. 2.
6. **Dijk, C G C van.** (1995) 'New insights in computer aided conceptual design', Design Studies, Vol. 16, No.1, p.62-80.
7. **McCullagh, K.** Current research project: 'To investigate the processes by which computer aided techniques are integrated into industrial design consultancy practice', University of Northumbria.
8. **Rust, C. et al.** (1993), 'The management of information technology in the professional practice of three dimensional design', Sheffield Hallam University, ISBN 0863393748.
9. **Schon, D A.**, (1991), 'The reflective practitioner, how professionals think in action', Avebury.
10. **Temple, S.** (1994) 'Thought made visible - the value of sketching', Co.-Design, 10/11/12.
11. **McNiff, J.**, (1988), 'Action research: principles and practice', McMillan, London.
12. **Cooper, R, D.** (1995) 'Setting a research framework', Co.-Design, 01/02/03.