

Northumbria Research Link

Citation: Prasad, Manjunath, Gregson, Barbara, Hargreaves, Gerard, Byrnes, Tiernan and Mendelow, Alexander Mendelow (2007) Inversion therapy in patients with pure single level discogenic disease: a pilot randomised trial. In: 13th European Association of Neurosurgical Societies Congress, 3-7 September 2007, Glasgow.

URL:

This version was downloaded from Northumbria Research Link: <http://nrl.northumbria.ac.uk/24344/>

Northumbria University has developed Northumbria Research Link (NRL) to enable users to access the University's research output. Copyright © and moral rights for items on NRL are retained by the individual author(s) and/or other copyright owners. Single copies of full items can be reproduced, displayed or performed, and given to third parties in any format or medium for personal research or study, educational, or not-for-profit purposes without prior permission or charge, provided the authors, title and full bibliographic details are given, as well as a hyperlink and/or URL to the original metadata page. The content must not be changed in any way. Full items must not be sold commercially in any format or medium without formal permission of the copyright holder. The full policy is available online: <http://nrl.northumbria.ac.uk/policies.html>

This document may differ from the final, published version of the research and has been made available online in accordance with publisher policies. To read and/or cite from the published version of the research, please visit the publisher's website (a subscription may be required.)



**Northumbria
University**
NEWCASTLE



UniversityLibrary

Inversion therapy in patients with pure single level discogenic disease: a pilot randomised trial

Manjunath Prasad KS, Gregson BA, Hargreaves G, Byrnes T, Mendelow AD.
Regional Neurosciences Centre, Newcastle General Hospital, Newcastle Upon Tyne, UK.

INVERSION

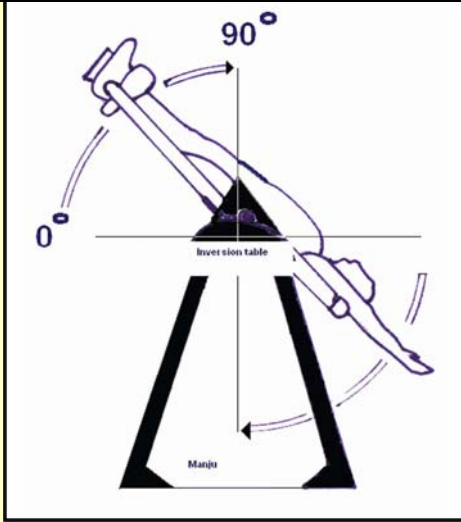

INTRODUCTION

- Economic and social costs of discogenic disease and its treatment are well known.
- Surgery is a well established option in the management flowchart.
- Impact of any treatment to offset the costs of the disease and/or surgery is obvious.
- No strong evidence proving that traction for sciatica is ineffective.
- Previous trials of traction have not reported on avoidance of surgery as an outcome measure.

AIM

- To study the feasibility of a randomised controlled trial of the impact of the inversion device in a single level discogenic disease on various outcome measures.

METHODS

Design: Prospective randomised control trial

Study details

- Period: Feb 2003 – Sept 2006
- Centre: Regional Neurosciences Centre, Newcastle upon Tyne

Protocol

➤ **Inclusion**

- Sciatic due to single level disc protrusion
- Within 6 months of first episode
- 18-45 years of age

➤ **Exclusion**

- Neurological deficits
- Sphincter disturbances

➤ **Arms**

- Randomised to inversion and regular physiotherapy or physiotherapy alone whilst waiting for surgery

➤ **Outcome Measures**

- Assessment at 6 weeks post therapy

Inversion

- Inversion is a form of extreme traction aided by gravity
- Inversion tables can be mechanical or motorised
- Inversion in our trial was used as intermittent traction along with standard physiotherapy whilst waiting for surgery

Outcome Measures

- Avoidance of surgery
- Roland Morris (RM) questionnaire
- SF-36
- Oswestry disability index
- MRI appearance

RESULTS

Patients

- Number: 22
- M:F: 1
- Age: 25-44 years

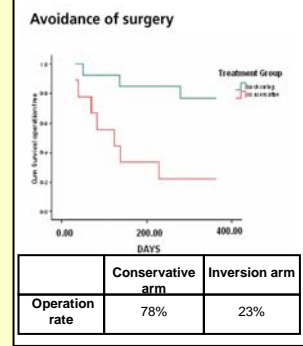
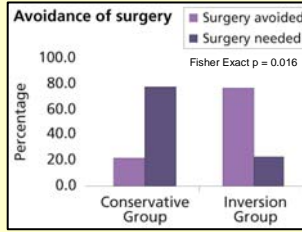

• **Roland Morris questionnaire***

No significant difference between the two groups.

* 19 patients: No data for one patient and two were operated on before final assessment.

Short Form 36*

No significant difference between the two groups.

* 19 patients: No data for one patient and two were operated on before final assessment.

Oswestry disability index*

No significant difference between the two groups.

* Oswestry assessment was done for only 8 patients – 4 in each group

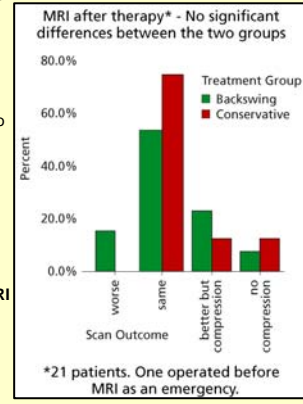

Scoring system for post randomisation MRI

- Worsened prolapse/ compression -1
- Unchanged 0
- Decreased prolapse/ compression 1
- Prolapse seen but no compression 2
- Complete disappearance 3

DISCUSSION

- The most comprehensive systemic review by Clarke et al. (2007) states that there is moderate evidence that in patients with sciatica, traction is no different from other treatment measures.
- However avoidance of surgery, which is extremely important, has not been evaluated previously.
- This trial addressed that issue.
- Avoidance of surgery did not prejudice other outcome measures and vice versa.
- We have also introduced a scoring system for comparing pre and post therapy MRI.

CONCLUSION

- Inversion therapy decreased the need for an operation in sciatica due to single level disc protrusion to 23% as compared to 78% in the non-inversion group.**
- The economic impact is very significant.**
- A large multicentre prospective randomised control trial is justified.**

REFS

- Clarke JA, van Tulder MW, Blomberg SEI, de Vet HCW, van der Heijden GJMG, Bronfort G, Bouter LM. Traction for low-back pain with or without sciatica. Cochrane Database of Systemic Reviews 2007 Issue 3.
- Van der Heijden GJMG, Beurskens AJHM, Dirx MJM, Bouter LM, Lindeman E. Efficacy of lumbar traction: A randomised Clinical Trial. Physiotherapy 1995; 81(1): 29-35