

Northumbria Research Link

Citation: Malsane, Sagar (2015) The application of automated rule checking to existing UK building regulations using BIM technologies. Doctoral thesis, Northumbria University.

This version was downloaded from Northumbria Research Link:
<http://nrl.northumbria.ac.uk/id/eprint/25328/>

Northumbria University has developed Northumbria Research Link (NRL) to enable users to access the University's research output. Copyright © and moral rights for items on NRL are retained by the individual author(s) and/or other copyright owners. Single copies of full items can be reproduced, displayed or performed, and given to third parties in any format or medium for personal research or study, educational, or not-for-profit purposes without prior permission or charge, provided the authors, title and full bibliographic details are given, as well as a hyperlink and/or URL to the original metadata page. The content must not be changed in any way. Full items must not be sold commercially in any format or medium without formal permission of the copyright holder. The full policy is available online: <http://nrl.northumbria.ac.uk/policies.html>

**THE APPLICATION OF
AUTOMATED RULE CHECKING TO
EXISTING UK BUILDING
REGULATIONS USING BIM
TECHNOLOGIES**

SAGAR M MALSANE

PhD

2015

**THE APPLICATION OF
AUTOMATED RULE CHECKING TO
EXISTING UK BUILDING
REGULATIONS USING BIM
TECHNOLOGIES**

SAGAR M MALSANE

A thesis submitted in partial fulfilment
of the requirements of the
University of Northumbria at Newcastle
for the degree of
Doctor of Philosophy

Research undertaken in the
Faculty of Engineering and Environment

January 2015

Abstract

Building designs in countries like the United Kingdom are currently checked manually against a frequently changing and increasingly complex set of building regulations. It is a major task for designers and those bodies that are charged with enforcing building regulations. As a result, there can often be ambiguity, inconsistency in assessments and delays in the overall construction process. This scenario indicates the need for automated building regulation compliance checking, which is an easier and valid option. As part of this, a critical review is carried out of the building code compliance checking related efforts undertaken in different countries, including Australia, Singapore, Australia, Norway and USA. Furthermore, it is determined that the use of Building Information Models (BIM) and the Industry Foundation Class (IFC) standard is imperative for automated compliance checking in England and Wales.

Most of the initiatives mentioned above focuses on creating object based rules and mapping the entities encapsulated within them to the international building model schema. The schema is designed to support the needs of an international user and takes little consideration of national semantics (e.g. UK practice and culture). Hence, the research focuses on creating UK building regulation specific data model schema. The analysis of Part-B1 through knowledge formalisation has resulted in identification of over 120 semantic entities. Using the output, a Part-B1 data model schema has been developed using EXPRESS-G language. Thus, an England and Wales building regulation specific, semantically rich, object model schema appropriate for the requirements of automated compliance checking has been developed.

The data model schema development results into a document modeling method. This method was developed in a manner such that it would be applicable to model any building regulation technical document. The development of a document modeling method acts as a contribution to the knowledge as building experts, rule authors and computer programmers can use it for data modeling. The said methodology was implemented on a sample legislative document to validate its usefulness. Also through the research work, concepts such as knowledge formalisation and a clause filter system were coined and successfully utilised to overcome the issues related to unsuitability of building regulations. This work accounts as a contribution to knowledge due to its novelty. A clause filter system was developed primarily to extract appropriate information suitable for automated compliance checking. On the basis of various key findings, a detailed framework for automated compliance checking of the UK building regulations is delivered through the research work.

Table of Contents

Abstract.....	i
Table of Contents.....	ii
List of Tables	vii
List of Figures.....	viii
Frequently Used Abbreviations.....	x
List of Appendices.....	xi
Acknowledgements	xii
Declaration	xiii
CHAPTER-1:.....	1
Introduction.....	1
1.1 Background.....	2
1.2 Problem statement and intention of the thesis	3
1.3 Research aim and objectives	6
1.4 Research process	6
1.5 Outline of the thesis	8
CHAPTER-2:.....	12
A Historical Review of Code Compliance Checking System Development Approaches.....	12
2.1 Background.....	13
2.2 Various approaches to code compliance system development	13
2.2.1 CORENET (Singapore).....	14
2.2.2 Design Check (Australia).....	16
2.2.3 International Code Council (United States).....	17
2.2.4 Statsbygg (Norway)	18
2.2.5 Solibri Model Checker (Finland)	20
2.2.6 Work done in other places	21
2.2.7 Lack of research in UK	21
2.3 Strengths and weaknesses of various approaches	22
Strengths	23

Weaknesses	24
2.4 Conclusion.....	24
CHAPTER-3:.....	26
Industry Foundation Class Standards and Interoperability.....	26
3.1 Introduction.....	27
3.2 Background.....	27
3.3 Technological development/Development of CAD Tools.....	28
3.3.1 The adoption of CAD.....	28
3.3.2 Building Information Modelling	29
3.3.3 Open BIM Standards	30
3.4 Industry foundation class standard	31
3.4.1 IFC layering structure and domain knowledge.....	32
3.5 IFC standards for interoperability.....	33
3.6 CAD exports into Industry Foundation Classes.....	34
3.7 A paradigm shift.....	35
3.8 Conclusion.....	35
CHAPTER-4:.....	37
Theoretical Context for Object Based Model Development	37
4.1 Introduction.....	38
4.2 Background.....	38
4.3 Selection of a data sample	39
4.4 Use of an appropriate sampling method	40
4.4.1 Convenience sampling.....	40
4.4.2 Judgement sampling.....	41
4.4.3 Theoretical sampling	41
4.5 Overview of the selected data sample	41
4.6 Use of the data filter system.....	42
4.6.1 Filter one	43
4.6.2 Filter two	44
4.6.3 Filter three	45
4.7 Data modelling.....	45
4.7.1 Conceptual data modelling	46
4.7.2 Classical data models.....	46
4.7.3 The hierarchical data model.....	46
4.7.4 The network data model	47
4.7.5 The relational data model	47

4.7.6	The semantic data model	47
4.8	Need for a semantic model.....	47
4.8.1	Supplementing additional entities	48
4.9	Capabilities and significance of STEP model data and IAI	48
4.10	EXPRESS-G described as a modelling language	49
4.11	Theoretical context initiating model development	54
CHAPTER-5:.....		55
Knowledge Formalisation – a prerequisite for the object model development		55
5.1	Introduction.....	56
5.2	BIMs and IFC	56
5.3	The England and Wales building regulations – suitability	57
5.3.1	Subjective and complex in nature	57
5.3.2	Inconsistent use of terminologies	58
5.3.3	Complexity of their structuring and inter-relationships.....	58
5.4	An object oriented approach.....	59
5.5	Knowledge formalisation	59
5.5.1	Significance of knowledge formalisation.....	60
5.6	Execution of knowledge formalisation	60
5.6.1	Selection of a data sample	60
5.6.2	Use of data filtering system.....	61
5.6.3	Elemental view of the building regulations.....	64
5.7	Initiating object data model development.....	70
5.8	Conclusion.....	70
CHAPTER-6:.....		72
Development of Object Based Building Regulation Model.....		72
6.1	Introduction.....	73
6.2	Necessity for an object model	74
6.2.1	Building information models lack data.....	74
6.2.2	Building models exported to IFC	74
6.2.3	IFC international standard data.....	75
6.3	Fundamental principles used in the development	76
6.3.1	Object identification.....	76
6.3.2	Object transformation into classes	77
6.3.3	Defining attributes of simple types and enumeration type	78
6.3.4	Establishing semantic relationships	79
6.4	Building regulation model – summarised process.....	82

6.5	Modelling of key abstract concepts.....	84
6.6	Strategies adopted and exceptions made	88
6.6.1	Use of different simple data types	89
6.7	Structuring of object data model.....	89
6.7.1	Need for structuring.....	89
6.7.2	Methodology for structuring.....	90
6.8	Observations.....	94
6.8.1	Interoperability.....	94
6.9	Understandability	96
6.10	Conclusion.....	100
CHAPTER-7:.....		102
Validation of the Developed Methodology for Modelling		102
7.1	Introduction.....	103
7.2	Summing up the document modelling methodology	103
7.3	Validation by implementation	106
7.3.1	Selection of a generic document.....	106
7.3.2	Use of a filter system.....	107
7.3.3	Extracting semantics.....	109
Part-2: Development of the object data model		110
7.3.4	Development of the data model	110
7.3.5	Data model structuring	114
7.4	Conclusion.....	116
CHAPTER-8:.....		117
Conclusions and Recommendations		117
8.1	Introduction.....	118
8.2	Conclusions.....	118
8.2.1	Objective One - <i>to review England and Wales Building Regulations</i>	118
8.2.2	Objective Two - <i>A critical review and a comparative analysis</i>	120
8.2.3	Objective Three - <i>to review BIM and IFC</i>	121
8.2.4	Objective Three – <i>to optimise the extraction of computer interpretable rules</i>	122
8.2.5	Objective Four – <i>To develop England and Wales building regulations</i>	123
8.2.6	Objective Five – <i>To validate the developed modelling methodology</i>	125
8.3	Contribution to Knowledge.....	126
8.3.1	Implications on practice	129
8.4	Limitations	130
8.4.1	Limitations with regards to data collection and data sampling	130

8.4.2	Limitations with regards to the review of systems	130
8.4.3	Limitations with regards to the use of a framework.....	131
8.5	Recommendations for future research.....	131
8.5.1	Recommendations to building model authors.....	131
8.5.2	Recommendations in relation to document authoring.....	132
8.5.3	Recommendations in relation to open standards.....	133
8.6	Closing Remarks.....	133
References		135
Appendix A: Fire Safety Object Data Model		xiv
Appendix B: Data analysis using filter system		xviii
Appendix C: Compliance Checking Process.....		xxi
Appendix D: List of Publications.....		xiv
Appendix E: Building regulation fire safety part B1		xv

List of Tables

Table 2.1: Overview of rule checking systems

Table 4.1: Various options of simple data types available

Table 4.2: Various Aggregations types available for data modelling

Table 5.1: Forming clause categories as part of the knowledge formalisation for part B1

Table 5.2: Entities spread over England and Wales Fire Safety Part B1 and Part B2

Table 5.3: Examples of declarative clauses and their breakdown

Table 5.4: Examples of informative clauses and their breakdown

Table 6.1: Resemblance between fire safety Building Regulation sections and EXPRESS-G classes

Table 6.2: Extracted objects' resemblance to IFC objects

Table 6.3: Classes showing resemblance to building regulation sections

Table 6.3: Classes showing resemblance to building regulation sections

Table 7.1: House rules grouped into categories using filters

Table 7.2: Classes showing resemblance to building regulation sections

Table 8.1: Approved documents classification on the basis of building aspects

Table 8.2: Comparison of various automated compliance checking systems

Table 8.3: Research objectives and respective chapter numbers

List of Figures

- Figure 1.1: Research process flow chart
- Figure 1.2: Research process and chapter scheme
- Figure 2.1: e-PlanCheck/FORNAX system environment
- Figure 2.2: Solibri Model Checker desktop window
- Figure 2.3: Review of implementation efforts undertaken on rule checking systems
- Figure 3.1: The overall architecture of the IFC model
- Figure 4.1: Overview of Fire Safety Part-B, Volumes B1 and B2
- Figure 4.2: Information filter system applicable to clauses
- Figure 4.3: Data modelling types
- Figure 4.4: Express/Express-G association
- Figure 4.5: Entity Space, abstract supertype
- Figure 4.6: Cavity enumeration types and its use
- Figure 5.1: Part B is fire protection and has subtypes B1 and B2
- Figure 5.2: Total number of clauses (sample size) considered
- Figure 5.3: Sorting out clauses into different categories
- Figure 5.4: Representation of the number of entities extracted from Part B1, B2 and G
- Figure 6.1: Entities identified from the fire safety clauses
- Figure 6.2: Entities into entity classes
- Figure 6.3: Habitable space modelled as an entity class
- Figure 6.4: Entity class cavity barrier shows supertype-subtype relationship
- Figure 6.5: Development of an object class from Fire Safety Part B1 1.15
- Figure 6.6: Object class Detector represented in Express-G.
- Figure 6.8: Representation of the abstract concept of means of escape
- Figure 6.7: Habitable space modelled as an entity class

Figure 6.9: Representation of the abstract concept of habitable space

Figure 6.10: Entity class building site representations

Figure 6.11: Use of attributes from resource domain

Figure 6.12: Entity relationship diagram for compartment class

Figure 6.13: Class CavityBarrier (abstract) representation

Figure 6.14: Class fire separating element representation

Figure 7.1: Legislative document modelling methodology

Figure 7.2: Selected sample size

Figure 7.3: House rule categories along with total number

Figure 7.4: Entity classes including kitchen, food cooking, heat detector, and saucepan

Figure 7.5: Object to object type relationship between kitchen, heat detector and saucepan

Figure 7.6: Entity class OvenCooking having a supertype-subtype relationship with FoodCooking

Figure 7.7: Supertype-subtype relationship between class Exit and class FireExit

Figure 7.8: Entity NonCompliance possesses result types enumeration values

Figure 7.9: Student regulation specific data model

Figure 7.10: Use of Resource Domain

Figure 8.1: Mappings using the domain extensions approach

Figure 8.2: Major Conceptual overview of automated compliance checking

Frequently Used Abbreviations

AEC - Architecture Engineering Construction

AI - Approved Inspector

BCB - Building Control Bodies

BIM - Building Information Modelling

CAD - Computer Aided Drawings

CityGML - The City Geography Mark-up Language

CORENET - Construction and Real Estate NETWORK

CSM - Constraint Set Manager

CSIRO - Commonwealth Scientific and Industrial Research Organisation

EDM - Express Data Manager

GBXML - Green Building Extensible Mark-up Language

GSA - General Services Administration

IAI - International Alliance for Interoperability's

ICC - International Code Council

IFC - Industry Foundation Class

LA - Local Authority

MCS - Model Checking Software

NBC - National Building Codes

RIBAE - Royal Institute of British Architects Enterprises

SMC - Solibri Model Checker

STEP - Standard for the Exchange of Product Model Data

UML - Unified Modelling Language

XML - Extensible Mark-up Language

List of Appendices

- Appendix A** List of publications as part of this research
- Appendix B** A list of web-based case studies
- Appendix C** Building regulation specific object model
- Appendix D** Available BIM guides, reports and visions
- Appendix E** Building regulation fire safety part B1
- Appendix F** House rules for student accommodation

Acknowledgements

Many people have provided me with assistance, guidance, and support over the past few years, without them it would not have been possible to complete this thesis. First and foremost, I would like to express my heartfelt gratitude to my supervisors Professor Steve Lockley and Dr. Jane Matthews for their guidance, timely discussions, constructive comments and critical reviews and exceptional support. This research would not have been possible without the support from my supervisors.

I would like to thank RIBA Enterprises for showing keen interest in this research project and providing financial assistance. In addition, my appreciation goes to research administration staff and other member of school of architecture and the built environment.

In addition, I would like to express my deepest appreciation to my family for their patience, continuous moral support and encouragement during the course of this research, especially to my wife Samhita.

I would like to convey special regards to my friends; Amey, Nagendra, Eiman, Tariq, Farah, Nesma for their support throughout this PhD research. I wish to thank my friends and housemates from Newcastle; Abhinav, Harvindar, Ritesh, Akshay, Vishal, Ajay.

Sagar M Malsane
PhD Built Environment - Research
Engineering and Environment
Northumbria University

Declaration

I declare that the work contained in this thesis has not been submitted for any other award and that it is all my own work. I also confirm that this work fully acknowledges opinions, ideas and contributions from the work of others. The work was done in collaboration with the Royal Institute of British Architect Enterprises (RIBAE).

Any ethical clearance for the research presented in this thesis has been approved. Approval has been sought and granted by the University Ethics Committee.

I declare that the Word Count of this Thesis is 41,216 words

Name: Sagar M Malsane

Signature:

Date:

Chapter-1:

Introduction

1.1 Background

National building codes are “a collection of regulations adopted by a city to govern the construction of buildings” (Satti & Krawczyk, 2004). Building codes play a key role in the safety of life and property by helping to protect from fire and other environmental hazards. Building codes are applicable to construction, alteration, movement, enlargement, replacement, use and occupancy, location, maintenance, removal and demolition (Dimyadi & Amor, 2013). Building codes are written so that the build forms will follow the minimum requirements, such as means of exit, structural stability, sanitation, light and ventilation, and conservation of energy. Built environments are expected to be designed and executed according to rules so as to ensure safety and well-being. A building is subject to multiple regulatory assessments throughout its lifecycle stages, including planning, construction, facility management, and demolition (Woodson, 2006).

Manual checking of building regulations is the conventional practice for compliance checking in the architecture, engineering and construction (AEC) industry. However, manual checking of building codes using a thick set of drawings (common with large scale and complex buildings) is laborious, error prone and time consuming, hence it is difficult to assume that it is a valid and fair procedure (Greenwood, Lockley, Malsane, & Matthews, 2010; Jeong & Lee, 2008). Manual building regulation compliance is complex and human errors can occur many times during the approval process, which results in high and long term costs (Tan, Hammad, & Fazio, 2010). In building regulation compliance checking, building designs are checked against various regulatory requirements, which means there are different departments and organisations expecting documentation, although they do not necessarily share a common vision of such monitoring (Fenves, Garrett, Kiliccote, Law, & Reed, 1995).

Building design is regulated and monitored by a number of national codes, regulations, commands, recommendations and standards (Hjelseth, 2009). As part of the approval process, designs are subjected to formal audit by the consent processing authority. During the construction stage, each building component is checked before and after installation to ensure that the quality of products and workmanship conforms to the required national standards. During the operation or facility management stage too, audits take place to ensure that the building is operating and maintained as per the required standards (Dimyadi & Amor, 2013).

During the designing stage, building designers are expected to ensure that every aspect of their design complies with various regulatory requirements. Manual checking of design compatibility against building codes is a rigorous process as designers need to read relevant code sections, interpret their content and then analyse any design alterations needed as per the building codes (Eastman, Lee, Jeong, & Lee, 2009). Building codes are not necessarily structured and

described in a way that will help designers to visualise any code problem in their design. Often, designers and building permit-issuing bodies have different interpretations of the same code, which leads to ambiguity. At the time of the rule checking process such ambiguities can prove costly, time consuming to rework and eventually cause delays in construction (Satti & Krawczyk, 2004). This scenario indicates the need for automated building regulation compliance checking, which is an easier and valid option (Hjelseth, 2009). If we are automatically able to check for building regulation compliance, existing problems resulting from manual checking can be eliminated. Automated compliance checking will not only prove beneficial to building designers but also to building certifiers, consultants, building code authorities, specification writers and builders (Ding, Drogemuller, Jupp, & Rosenman, 2006). 85% of architects are interested in automated building regulation compliance checking as they spend a substantial amount of time (more than 50 hours per project) on manual checking of building regulations (Jeong & Lee, 2008).

An automated building regulation compliance checking application is “something that assesses a design on the basis of the configuration of objects, their interrelationships or attributes. Since code compliance checking is often a costly bottleneck in the building delivery process, code reviews have the potential to save significant time and cost” (Eastman et al., 2009). Automated code compliance checking related research has been going on since the 1960s (Hjelseth, 2009). It involves automatic checking of building plans represented by Building Information Modelling (BIM) for code compliance via Model Checking Software (MCS) (Choi & Kim, 2008).

On the basis of the background, this PhD research attempts to optimise the feasibility of automated code compliance checking process against the complex set of England and Wales building regulations by designing a suitable object data model schema. Further it focuses on the development of a building regulation document modelling methodology for computer interpretable representation. What are the problems and challenges exist in this effort are explained in the following section.

1.2 Problem statement and intention of the thesis

The Building Act 1984 is a key piece of legislation that applies to England and Wales and comprises the Building Regulations and Building Control system. The Statutory requirements are published officially by the Royal Institute of British Architects Enterprises (RIBA) in the form of Building Regulation Approved Documents (NBS, 1996). These approved documents consist of clauses which are written in a natural language format. They set out the standards to which building works must comply. The Building Regulations apply to most building work, as buildings are expected to meet criteria from an organisational, financial, environmental and social perspective (Hjelseth, 2009; Satti & Krawczyk, 2004). Responsibility for compliance

checking is primarily shared by Building Control Bodies (BCBs); through either a Local Authority (LA) or a private sector Approved Inspector (AI). The applicant involved in the work has the flexibility to approach either a Local Authority Building Control or Approved Inspector Building Control but he needs to notify the authorities of his decision jointly in the form of an 'Initial Notice' (NBS, 1996; RIBAEnterprises, 2006).

The England and Wales Building Regulations 'Approved Documents' consist of clauses that are written in a natural linguistic format. In their present form they are not suitable for automated compliance checking. They also, by their nature, make the transition to automated compliance checking a difficult process (NBS, 1996). Hence, it is important to investigate its potential and feasibility for data modelling so that they can support automated compliance checking.

Traditionally, designs have been represented in 2D format, with an emphasis on making them graphically and visually as correct as possible to enable professionals to understand and interpret them for necessary building information (Eastman et al., 2009; Hiekkila & Blewitt, 1992; Jeong & Lee, 2008; Nguyen, 2005). However, the use of graphical information alone is not suitable, i.e. the traditional way of presenting information in the form of lines for advanced matters such as building regulation compliance checking (Holtz, Orr, & Yares, 2003). At present the AEC industry is in a transition from paper and 2D Computer Aided Drawing (CAD) to fully 3 dimensional BIM. To create a BIM, a modeller uses semantically rich objects to build a virtual prototype. The resulting 3D integrated model is a far more rich representation of a building project than the traditional 2D drawings. The ability to attach 'properties' to objects means that the use of BIM is potentially a far more convincing instrument in communicating building designs in terms of obtaining sanction from the rule checking authorities. Hence, BIM has an advantage over other such systems, as it stores information in the form of collection of objects with associated properties (Davies & Raslan, 2010; Holzer, 2009; Niemeijer, Vries, & Beetz, 2009; Sullivan, 2007).

The drawings are expected to contain all the necessary information required for building regulation compliance checking purposes, but this is often not the case. Although BIM is becoming popular, it is not common for models to contain semantically rich information; they may lack England and Wales building regulation specific entities or the related details required for automated compliance checking. Hence for building regulation compliance checking, designers have an extra share of responsibility and must prepare models in such a way that they provide the information needed according to a well defined and agreed upon structure (Eastman et al., 2009; Jeong & Lee, 2008; Kymmell, 2008).

The full benefits of BIM will materialize only through sharing of information across organisations, departments, information technology systems and databases (Bernstein & Pittman, 2004; Love, Simpson, Hill, Matthews, & Olatunji, 2014). The industry foundation

class (IFC) standard is the key to facilitating this interoperability in a cost-effective way and without relying on any particular product or vendor specific file formats (Conover, 2009; Solibri, 1999). IFC adds a common language for transferring information between different BIM applications, while maintaining the meaning of different pieces of information in the transfer (Ding et al., 2006; Eastman et al., 2009; Holzer, 2009). The International Alliance for Interoperability's (IAI) IFC standard is implemented in all the major BIM packages. It can consistently export valid IFC data files describing a building design, including the model hierarchy, properties and behaviours of building objects. IFC is suitable in terms of standardisation, unambiguity, consistency and completeness of description of building designs (Jones, 2007; Khemlani, 2005).

The strategy adopted in most compliance checking initiatives has been to convert proprietary BIM models into the IFC and then to author bespoke compliance rules that can be executed using this model (Eastman et al., 2009). The problem with this approach is that the international BIM tools do not populate these IFC models with all the required data; in particular, the relationships with England and Wales building regulations. Thus, for reliable compliance checking, additional data must be provided by the design team as a separate activity.

The intention of this research is to focus on the problems such as:

- The unsuitability of England and Wales building regulations due to its human linguistic format.
- Current BIMs lacking the England and Wales building regulations specific semantics required for automated compliance checking.
- IFC acts as an international interoperability standard, focuses on international semantics.

The solution is to develop an object model which comprises national semantics specific to England and Wales building regulations. Object model will be developed, within the IFC model, by identifying concepts, objects and properties that are entrained in the building regulations (England and Wales). Most of the initiatives have focussed on creating a schema which is designed to support the needs of an international user and take little consideration of national semantics (Greenwood et al., 2010). Hence, this research has focussed on creating an English and Welsh building regulation specific object model schema which will be suitable to meet the requirements of UK code compliance checking.

Further the study's result is the development of a methodology for modelling a document; the methodology aims to be applicable to all parts of the England and Wales building regulations or to any similar legislative document which has a human linguistic format.

1.3 Research aim and objectives

The project intends to investigate the potential for digitisation of the England and Wales Building Regulations and to develop a method to construct an England and Wales building regulation specific object data model schema that enables automated compliance checking.

To achieve the above aim, the following objectives have been formulated:

- To review UK Building Regulations in terms of their structure, nature and suitability for automated building code compliance checking.
- To conduct a critical review and a comparative analysis of existing automated code compliance checking systems from different countries.
- To optimise the extraction of computer interpretable rules from the current UK Building Regulations data using a knowledge formalisation process.
- To develop a UK Building Regulation specific object based data model schema for code compliance checking; this information model in general should be inclusive of the national semantics specific to England and Wales.
- To validate the developed legislative document modelling methodology by applying it to a generic document and achieving the desired results.

1.4 Research process

Figure 1.1 shows the steps adopted in the research design to accomplish the project's aim. It illustrates the research methodology formulation and key research stages, such as the literature review, methodology, data collection, data analysis and research findings (Blaxter, Hughes, & Tight, 2010).

As part of the research methodology formulation and its execution, different philosophical approaches were studied in order to gain an understanding, such as ontology, epistemology and the empirical research approach (Bryman, 2004b; Oliver, 2004). Out of these three approaches, the empirical research approach was decided upon for use in the research. This approach represents a way of gaining knowledge by means of direct and indirect observation or experience. Empirical research is supported by evidence and here it involved a case study based approach to capture quality data which were suitable for the research (Bryman, 2004a; Cresswell, 2003).

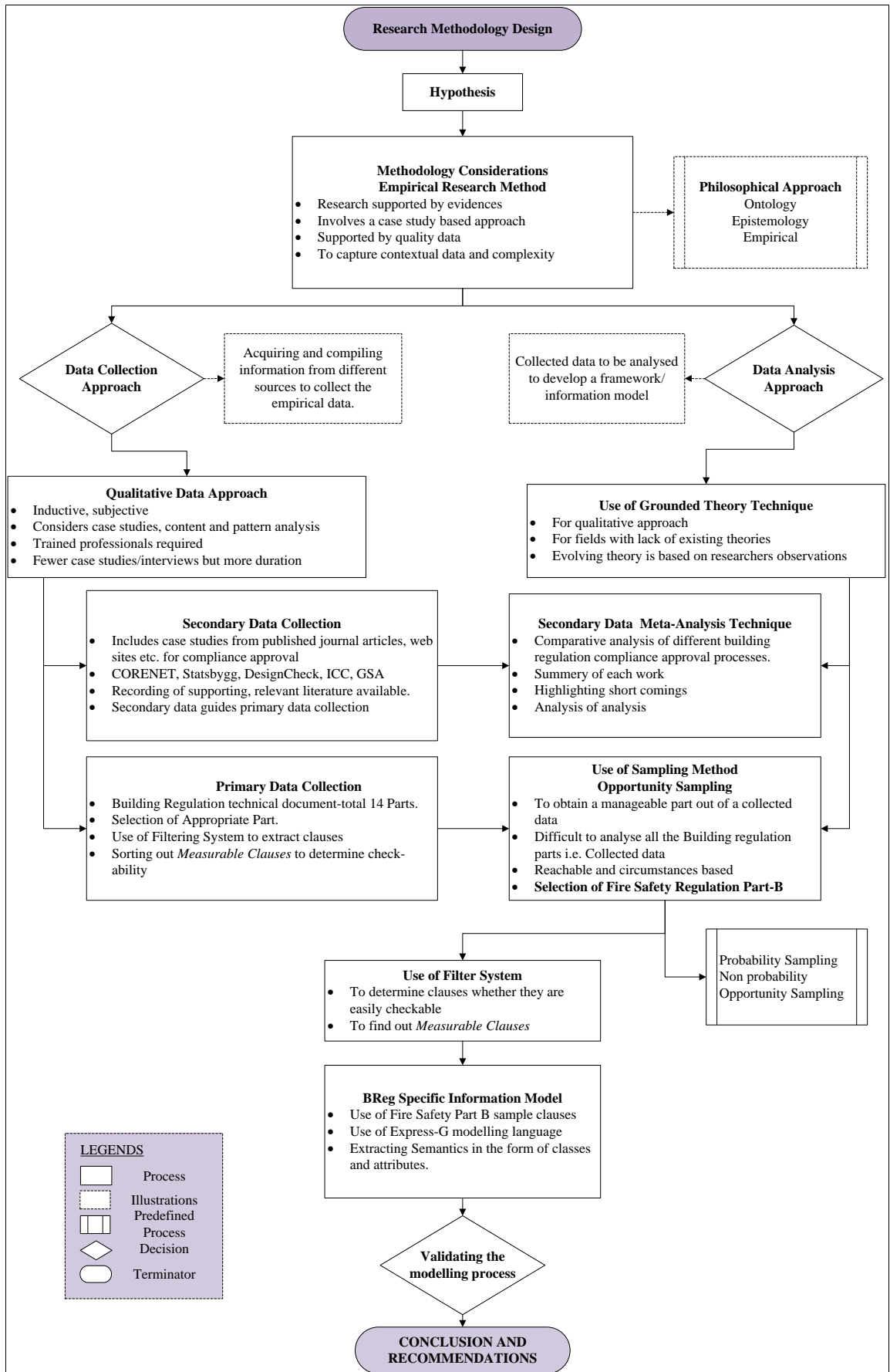

Figure 1.1: Design of Research process

The empirical research approach involves data that are qualitative in nature and these are collected by acquiring and compiling information from different sources in the form of primary data and secondary data. For data collection, a qualitative data approach was chosen. Primary data were collected in the form of UK building regulation technical documents published by RIBAE. These primary data, collected in the form of 14 approved documents, were significantly large in number to handle. Hence, the adoption of an appropriate sampling method was crucial to restrict the scope of the research work (Fellows & Liu, 2008).

Secondary data collection was carried out in the form of desk based case studies from published journal articles, websites, etc. Case studies included those of CORONET, Statsbygg, DesignCheck, International Code Checking and US-General Services Administration. It also involved gaining a theoretical understanding of the topic with the help of a literature review. Furthermore, it involved the study of Building Information Models (BIM) and the Industry Foundation Class (IFC) standard for their use in automated compliance checking in England and Wales (Levy & Ellis, 2006).

As a substantial amount of data was collected, it was important to get an overview of all the collected data and this was followed by a combination of an inductive and a deductive approach. A detailed review of each rule checking system and a consolidated view or summary of all the different rule checking systems helped in finding a set of observations which could lead to developing a theory. Using grounded theory and a meta-analysis technique, a code compliance related theory was developed on the basis of observations made from the data (Glaser & Strauss, 1999). A judgement sampling method was adopted to ensure a manageable part (Building Regulation Part-B1) of the data was selected. A filter system was developed to analyse the sampled data and a UK building regulation specific semantic data model was generated.

1.5 Outline of the thesis

This thesis is organised into seven chapters as represented in Figure 1.2. The *current chapter (Chapter One)* describes the research background, current research issues, the aim, the objectives and the structure of the thesis. *Chapter Two* critically reviews various approaches to code checking from different countries and their related implementation efforts. This study has been conducted with the help of published literature. The study of various code compliance checking approaches has been treated as a desk based case study exercise and data have been collected accordingly. They are considered secondary data and a comparative analysis has been carried out to understand similarities and dissimilarities between them. The study mainly helps in understanding the need for the development of an England and Wales specific building model

schema, rather than focussing on an international building model schema as such schemas take little consideration of national semantics.

Chapter Three explains the theoretical context in which the England and Wales building regulation specific data model has been developed, hence it addresses all issues which are related to the object model. It begins by pointing out the inability to check all types of building regulations through automated compliance checking. Hence, it explains the importance of carrying out classification to find out whether clauses should be considered for automated compliance checking or whether they should be checked manually. It introduces the concept of knowledge formalisation very briefly and explains data sampling selection methods, as data selection is an important stage of knowledge formalisation. Using an appropriate sampling method, the UK Approved Document Fire Safety Part B1 was selected and an overview of it is presented in this chapter. To classify building regulations, a data filtering system was created and this is also explained. Furthermore, this chapter introduces the concept of data modelling and its various types. The chapter ends with an explanation of Express-G, a data modelling language, as well as its core components.

Chapter Four focuses on the development of a method for the interpretation of England and Wales building regulations into a computer interpretable format for the facilitation of automated compliance checking. Two major concepts/activities are explained: knowledge formalisation of building regulations and the development of an object data model. To convert building regulation knowledge into computer interpretable rules, the suitability of building regulations is analysed and characteristics which make the transition difficult are explained. Furthermore, the process of knowledge formalisation is explained, including the steps involved in it, and the execution of knowledge formalisation is shown. At the end, the point is made that knowledge formalisation provides a foundation by making formalised knowledge of the England and Wales fire safety building regulations available, initiating the building regulation specific data model development work.

Chapter Five is about development of the England and Wales fire safety building regulations specific data model, using the output achieved through knowledge formalisation. Express-G modelling language is extensively used for the same. It begins by addressing the fundamental principles used for the development of the data model; the execution of each principle is explained in detail with appropriate examples provided. Following this, data modelling of key national level England and Wales building regulation specific concepts is explained using various examples, such as habitable room, escape routes, etc. Various strategies are employed for object model development. This chapter addresses the same and also explains why exceptions are made at times. Once the data development is complete, the data model is

structured for its better management. Using an IFC data model structure as a reference and creating different domains, these issues are highlighted.

Validation of the document modelling methodology which is developed in the previous two chapters is described in *Chapter Six*. To validate the methodology, it is applied to a generic house rules related document.

Appendices are presented in the remainder of the thesis which present material supporting this research. The sample Part-B1 fire safety document, research papers and object based data model is provided.

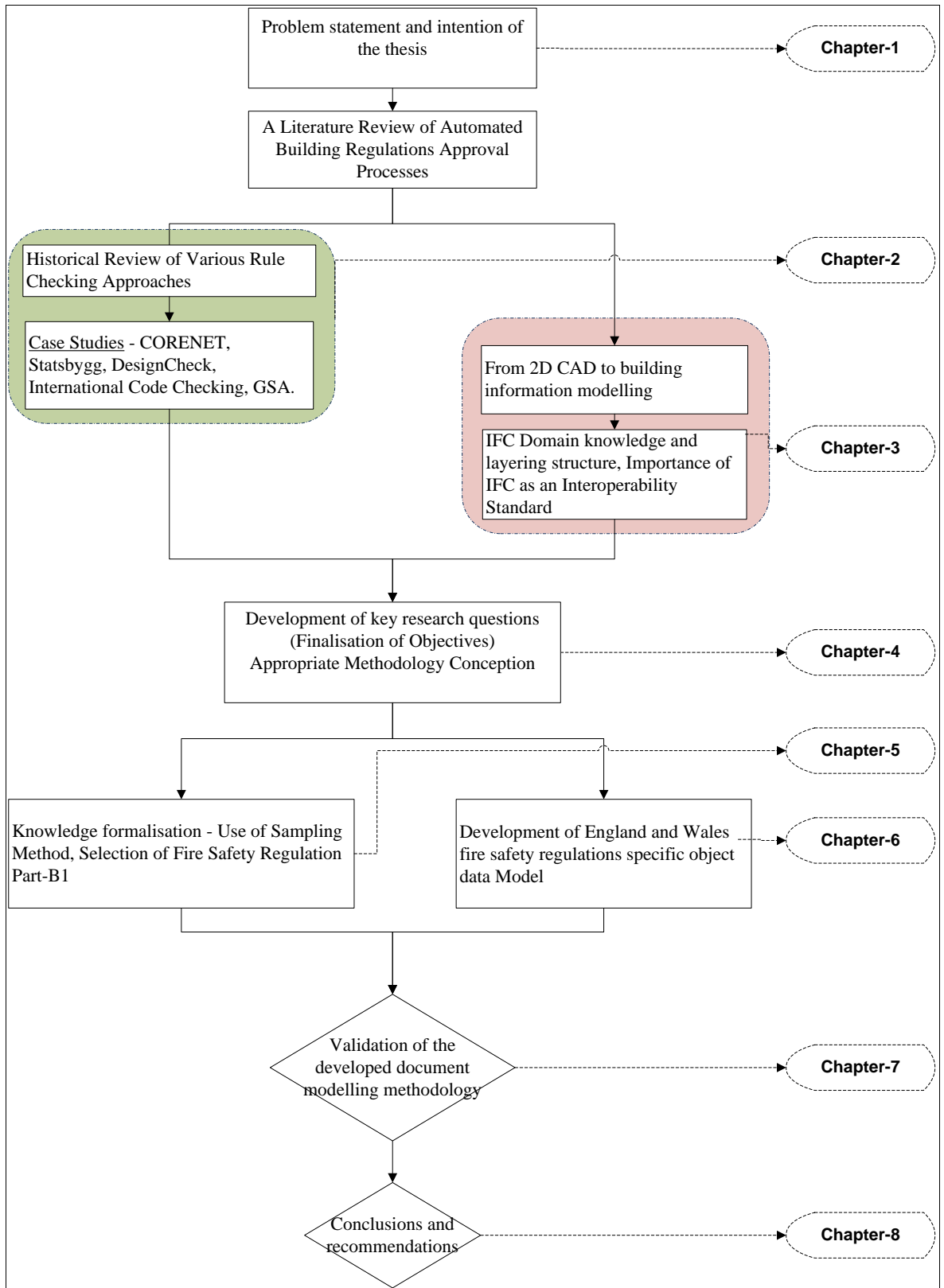

Figure 1.2: Research process and chapter scheme

Chapter-2:

A Historical Review of Code Compliance Checking System Development Approaches

2.1 Background

The aim of this research is to optimise the feasibility of digitising England and Wales building regulations to support automated compliance checking using BIM standards. Currently in England and Wales the process of building approval involves the manual checking of building designs or architectural designs for compliance against various frequently changing NBCs (Greenwood et al., 2010; NBS, 1996). Checking of building designs against building regulations for compliance is time-consuming and the manual checking process is highly dependent upon the building inspector's experience, judgement and skills (Fenves et al., 1995).

Automated building regulation compliance checking would improve these practices and provide a framework for consistent results. However, the automation of the building regulation checking procedure has been widely viewed as a complex and challengeable task to perform in computer-aided building design (DesignCheck, 2009).

After understanding and acknowledging the need for automated compliance checking, it was important to review various attempts at code compliance checking by different countries to understand the following issues:

- Major steps involved in code compliance checking;
- Associated processes related to development of code compliance checking;
- Issues and challenges encountered by various researchers;
- Issues observed in the work of others.

A critical review of code compliance related implementation efforts undertaken to date has been carried out. Both in literature and in practice there has been limited progress in automated compliance checking development. Automated code compliance related research has been going on since the 1960s (Hjelseth, 2009). It involves automatic checking of building plans represented by BIM for code compliance using MCS (Choi & Kim, 2008). In this research, such systems have been interpreted and studied, with data collected in the form of web based case studies, recorded and documented. The study of various code compliance checking approaches has been treated as desk based research, with data collected from case studies accordingly. These data are considered secondary data and they are analysed so as to draw conclusions (Blaxter et al., 2010; Cresswell, 2003).

2.2 Various approaches to code compliance system development

A detailed review of the rule checking systems that have been developed so far to assess building designs has been carried out and is presented in this section. This is to provide the context of the research undertaken. A similar review based on various criteria can be found in (Eastman et al., 2009).

To review existing building regulation compliance checking systems from different countries, a published paper based case study method has been employed. The research methodology also included web based case studies, as conducting actual case studies was impractical and prohibitive as it involved different countries. It was therefore decided to rely on web based case studies and published literature. The advantage of the web based case study method is its public accessibility through written reports (Fellows & Liu, 2008). At the first stage of the research methodology, a critical review of the implementation efforts undertaken to date related to rule checking was carried out. Five such systems were interpreted and studied; the data collected can be treated as secondary data. This was followed by preparation of data for analysis (Bryman, 2004b).

In the late 1980s, development of rule-based systems for building models began. In the 1990s, the development of IFCs led to initiatives using building model schema for building code checking. This initial research outlined the need for multiple object views for different types of rule checking, thus larger industrial-based efforts were needed (Eastman, Teicholz, Sacks, & Liston, 2008; Hjelseth, 2012)

2.2.1 CORENET (Singapore)

The BP-Expert system had been available in Singapore from as early as 1995 for checking 2D drawings. It was implemented with a view “to reengineer and streamline the fragmented work processes in the construction industry, so as to achieve quantum improvements in turnaround time, quality and productivity” (Evelyn & Fatt, 2004). In 2000 it was replaced by e-PlanCheck as part of the Construction and Real Estate NETWORK (CORENET) project (Sing & Zhong, 2001).

CORENET project was one of the first initiatives in automated code-checking, funded by the Singapore Ministry of National Development. It replaced the BP-Expert system in 2000 (Choi & Kim, 2008). The aim was to provide an internet based electronic submission system for checking and approving building plans. Building proposals were submitted as a combination of existing 2D drawings with additional information provided in supplementary IFC-based files. The system utilised many of convergent technologies, such as Object Orientated software design, Standard for the Exchange of Product (STEP) Model Data (Fenves et al., 1995), and adoption of graphical project technology. It was considered to be ‘cutting edge’ and conceptually strong, yet there is little evidence of continuing work on the specific initiative.

In Singapore, CORENET was one of the driving factors behind the move from a 2D design drafting approach towards a graphical BIM approach. BIM is used as a portable database which can be enriched by project information throughout the project lifecycle. Thus, it can provide a common platform for exchange of information speedily and seamlessly among all project

stakeholders, as well as with building approval regulatory authorities (Evelyn & Fatt, 2004; Sing & Zhong, 2001). As stated by (Khemlani, 2005), CORENET encouraged the Singapore construction industry to use BIM standards for code compliance checking in the form of the CORENET e-PlanCheck system which checked and approved building plans. This system is built on client-server architecture based on the internet with which building professionals can check applications for code compliance.

For infrastructure industry related building plan submission, checking and approval, CORENET comprises both an e-submission system and integrated plan checking system. As the name suggests, it involves an internet based system for submitting plans and documents for approval within a secure technical environment. IFC based files can be automatically checked by using integrated plan checking, which is a cutting edge system in the area of building regulations, artificial intelligence and BIM technologies (Choi & Kim, 2008; Khemlani, 2005).

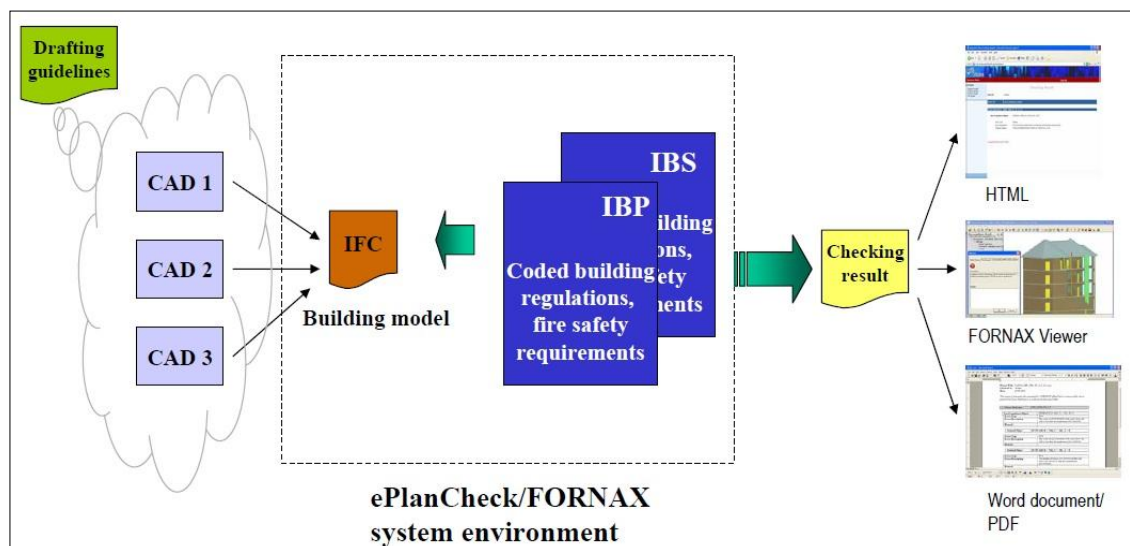

Figure 2.1: e-PlanCheck/FORNAX system environment (Khemlani, 2005)

Building professionals can use the e-submission system shown in Figure 2.1, by creating their own account and uploading a BIM with required information for the automated compliance checking process. The user needs to wait for a downloadable report which highlights the areas of non-compliance. Sometimes, competent professionals can view the building model graphically and highlight areas of non-compliance.

Singapore has adopted IFC as an interoperability standard to ensure long-term sustainability of BIM implementation, as it makes a BIM more stable. IFC standards are in their early stages of implementation and will be widely accepted in the future, and Singapore is supporting all international efforts to boost IFC adoption through the CORENET e-PlanCheck system (Greenwood et al., 2010; Khemlani, 2005).

IFC represents the basic geometrical building information which can be modelled by a BIM application. However; many of the requirements related to Singapore codes for compliance checking are not available in it. To provide a solution, e-PlanCheck commissioned an independent platform, FORNAX, along with the already existing EDM Model Checker. FORNAX is an object library written in C++ that provides the higher level of semantics required for Singapore code checking. Objects represented through FORNAX contain all the relevant attributes for the Singapore codes, as well as the rules that apply to them. Each object has been designed to be extensible in order to cover the requirements of other countries, and as a result CORENET e-PlanCheck has been used as the basis for pilot projects in Norway, New York and Australia (Eastman et al., 2009; Greenwood et al., 2010; Khemlani, 2005).

CORENET demonstrated its first trial on the e-PlanCheck (architectural) system in the year 2004, involving seven architectural firms. The duration of the testing was eight months and each firm experimented with two ongoing or past building models in IFC format for checking. Overall, each firm spent two month's manpower on the project and it was compensated by CORENET with funding for their efforts. Results and related feedback have not yet been published by CORENET (Khemlani, 2005). Singapore's e-PlanCheck system is one of those rare projects on such a large scale in support of IFC and BIM technology (Evelyn & Fatt, 2004). Despite difficulties such as its inability to support the checking of design standards throughout the different design stages of a project (Ding et al., 2006) and ongoing attempts to implement performance based checking (Solihin, 2004), e-PlanCheck in Singapore is still the only system that is currently operational (Ding et al., 2006)

2.2.2 Design Check (Australia)

Buildings constructed in Australia have to comply with the Building Code of Australia. According to (Ding et al., 2006; Eastman et al., 2009), Design Check, active in Australia, is an advanced software tool that was developed to automate compliance checking of building codes with design. The Commonwealth Scientific and Industrial Research Organisation (CSIRO) initiated the project and it was funded by Australia's Cooperative Research Centre for Construction Innovation. The University of Sydney, Building Commission of Victoria, Queensland Department of Public Work, NSW Department of Commerce and Woods Bagot were other members/stakeholders involved in the project. Design Check was developed and used mainly for automated compliance checking of Australia's new requirements related to disability access design. However; it was also applicable to other types of building codes such as building maintenance, refurbishment and redevelopment. Victoria's Building Commission Director facilitated authentication for this software and it is currently on trial by the construction industry in Australia (Eastman et al., 2009).

Both the Solibri Model Checker (SMC) and Express Data Manager (EDM) were considered possible platforms for automated code checking in Australia, focussing on accessible design regulations (Ding et al., 2006; Eastman et al., 2009). However, (Ding et al., 2006) and (Greenwood et al., 2010) observed that Design Check uses object based rules, encoded using EDM. Building data models, in IFC format, were imported into the EDM database and transformed into the Design Check's internal model. Similar to e-PlanCheck from Singapore which uses FORNAX - an object library, Design Check includes EDM. The DesignCheck model includes specific building code information significant from a compliance checking point of view which is not currently incorporated by BIM (Hjelseth & Nisbet, 2010).

A mapping schema, written in Express, translates the building data model from IFC format into the Design Check schema. The strategy is similar to that of e-PlanCheck from Singapore; however, Design Check has a rule schema for early and detailed design stages, as well as for specification so that it can be used to check for compliance at various stages in the building design process. It is therefore targeted at architects and designers rather than just building control certifiers (Ding et al., 2006). As yet, DesignCheck does not have the ability to view 3D models and all reports are text based.

2.2.3 International Code Council (United States)

Work on code checking began in the United States (US) around 2000. Due to an emphasis on health, safety and welfare, the focus was on improving the procedure of how code officials handle building inspections, permitting processes and design, zoning reviews with the help of BIM technology, and integrated design review. A major driver of BIM and validation of BIM models in the US is the General Services Administration (GSA). The GSA issued BIM-guidelines in late 2006 regarding the use of BIMs so that it is more effective and active in the United State's AEC sector, the Public Building Service (PBS) sector in particular. In 2007, GSA proposed that all planners seeking funding for a spatial planning project would need to produce BIMs for validation in an open standard format. This has pushed the US construction industry into use of certain standards required by public clients; similar events took place in Denmark at the same time resulting in legal requirements. An online repository of government regulations is the easiest way for users to access or retrieve related documents (GSA, 2007; Holzer, 2009).

When the concept of automated compliance was in its embryonic stage in the United States, the International Code Council (ICC), a non-profit organisation, initiated the 'SmartCodes' project in conjunction with AEC3 and Digital Alchemy. According to the ICC, an automated code-compliance check is one which checks BIM data with model checker software. Regulatory officials can print the results or they can highlight the non-compliant elements/objects with an explanation of violation within the 3D BIM (Eastman et al., 2009).

The SmartCodes project focussed largely on addressing the problems of transforming paper based codes (of which there are thousands) into machine-interpretable rules. This was a lengthy process requiring much iteration between building code officials and software developers. In order to streamline this process, the SmartCodes project developed a methodology for applying tags to electronic copies of building codes using a 'tag dictionary', or ontology (Wix, Nisbet, & Liebich, 2008). The rules are then automatically extracted, following a strict mathematical pattern, into an IFC constraints schema. The resulting IFC constraints schema is mapped onto the IFC building data model via the tag dictionary. The rules can currently be executed using either SMC or AEC3 XABIO. The SmartCodes project does not support building code specific information that is not currently implemented by BIM vendors (Eastman et al., 2009).

In the US, electronic-rulemaking (E-rulemaking) has been introduced for the public to comment on proposed rules and regulations. This is an internet based system where people can post their comments and suggestions. The board considers this feedback and can revise the proposed rules and regulations if deemed necessary. This process has resulted in a large amount of public feedback which needs to be reviewed and analysed in relation to proposed rules (Lau, Kerrigan, Law, & Wiederhold, 2004; Sullivan, 2007).

According to the ICC, by sharing the common BIM, rather than the traditional method of using 2D drawings, building inspectors can review plans in comparatively less time. Due to this they can spend more time on site for better inspection. Designers and other consultants within the building construction community can submit plans within a stipulated time frame as they do not have to produce any different work and can deal with building regulation related issues more exclusively (Lau et al., 2004).

2.2.4 Statsbygg (Norway)

The CORENET work was developed and emulated in Norway with the ByggSok system (Haraldsen, Stray, Päivärinta, & Sein, 2004). ByggSok is a Norwegian e-Government system consisting of three modules: an information system, a system for e-submission of building applications, and a system for zoning proposals (Rooth, 2005). FORNAX, an object library used in Singapore's CORENET project, contains all the relevant attributes for codes, as well as the rules that apply to that object. Objects were designed to be extendible in order to cover the requirements of other countries, thus Norway emulated it with the ByggSok system (Greenwood et al., 2010).

ByggSok is heavily based on IFC standards. Work is ongoing and currently focuses on the issues of classification, terminology and standardising rule checking in construction on a global level. Statsbygg has been developed for providing electronic services for zoning and building related matters. Standards Norway and BuildingSMART Norway have actively supported

development efforts by the Norwegian Building and Construction industry in the area of building code compliance checking (Choi & Kim, 2008). Standards Norway is responsible for standardisation of Norwegian building standards. It has adopted and published some 1,500 new Norwegian building standards (Choi & Kim, 2008; Eastman et al., 2009). Standards Norway has been active with BuildingSMART Norway since 2005 on a national and international level and is in charge of international (IFD) library development in Norway. In 2010, they worked on a classification system, model checking, specification system, and building and construction standard contracts. Together they developed MCS in combination with Norwegian building regulations. BuildingSMART Norway works to support the standardization of work and streamline the implementation of specific construction projects (Bell, Bjorkhaug, & Hjelseth, 2009).

Building upon their e-PlanCheck pilot projects, Norwegian developers (Statsbygg) have experimented with multiple systems as part of their efforts to extend the use of IFC based BIM to the entire project lifecycle. The resulting systems have been piloted on real projects, with data being exchanged through a wide selection of software to suit the various stages/tasks of the project lifecycle.

The Norwegian BIM pilot project HITOS is managed by the Statsbygg governmental agency and code checking efforts focus primarily on accessibility design. The building model data are stored and accessed through the EDM Model Server in IFC format. The accessibility rules are mapped to their associated building objects and executed using SMC's Constraint Set Manager (CSM). Solibri has the potential to assess building model data in IFC and retrieves objects related to accessibility rules. As yet, data rules implemented focus predominantly on simple geometrical constraints, and as such, the objects and parameters are supported by IFC data models produced by current BIM packages.

The Statsbygg Solibri system does not support the enhancing of these data models or export to IFC format, thus it cannot currently be used for compliance checking of attributes not supported by current BIM vendors. The Solibri CSM is implemented in java and ships with a library of built-in parameterised rules which can be configured by adjusting the parameters. New rules, however, must be custom made in collaboration with the Solibri software developers, and as such, are not easily adapted for other software. Solibri has the benefit of a powerful 3D modelling engine which, in combination with the ability to directly read IFC files, allows for clear visual reporting of rule infringements for the user. Solibri's built-in rule library contains rules for validating a data model prior to rule checking, which is useful (Eastman et al., 2009; Greenwood et al., 2010).

2.2.5 Solibri Model Checker (Finland)

The SMC of Solibri Co., Finland, is the most widely known software currently available for building model checking (i.e. BIMs). CORONET (Singapore) and SmartCodes of ICC (USA) have both used the SMC in their code checking research development. SMC checks faults in building design models and analyses models for their integrity (Ding et al., 2006; Khemlani, 2009).

BIMs can be exported into IFC format as IFC acts as the neutral data model representation standard. IFC is a tool for independent and neutral data model representation for describing a building's rule checking process. Such IFC files can be checked for suitability based on pre-defined rules with the help of Solibri (see Figure 2.2). SMC is a java-based desktop platform application that reads an IFC standard file and maps it to an internal structure, facilitating access and processing. Solibri checks mainly simple geometrical rules such as whether necessary spaces match standards, validation and constraints for specific objects (Eastman et al., 2009; Jeong & Lee, 2008).

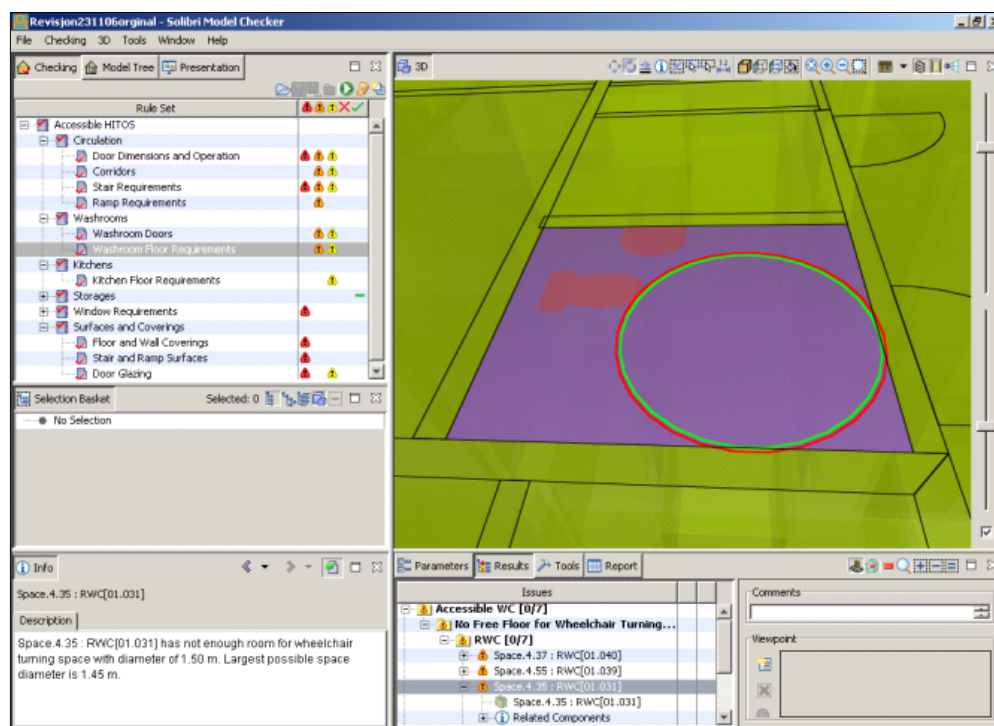

Figure 2.2: Solibri Model Checker desktop window

EDM is a system with an object based rule engine. EDM provides a shared data repository and is compatible with IFC. Compared to EDM, SMC provides a CSM for managing and configuring sets of constraints, supporting design 'spell-checking'. SMC provides automated design spell-checking to a building model and is capable of directly interfacing with an object-based architectural CAD system (Ding et al., 2006). SMC provides a well-developed reporting

system with 3D visualisation. The reporting interface allows designers or users to view the constraints being checked, update constraints and toggle between the reporting results and constraint specifications.

Through the CSM, users can configure their own check list to designate items using pre-defined rules and adjust associated parameters. Solibri displays item-wise rule checking results visually and simplistically, which facilitates the immediate preparation of detailed reports. SMC follows the IFC international standard format, yet there are cases where errors occur in exporting files, making it difficult to ensure accurate checking. Although this problem is not unique to SMC, it is the one that has to be solved from a technical point of view in BIM development (Jeong & Lee, 2008).

2.2.6 Work done in other places

The Netherlands have developed a method for computational checking of BIMs for approval of building designs based on building regulations. This method mainly involves checking of a data model exported in an IFC format which has constraints entered in it. IFC format is widely accepted, the most stable and it has the capability to store semantic information. For checking constraints on buildings, the use of graphical information alone is not satisfactory, i.e. the traditional way of presenting information in the form of lines. Due to this, BIM has an advantage over 2D CAD systems as it stores information in the form of a collection of objects with associated properties (Niemeijer et al., 2009). This concept of using constraints for checking designs came from the mechanical engineering industry. The building industry did not adopt it widely and only Revit (focusing on geometrical constraints) and SMART codes (focusing on building codes) show relevance to such a system. Not much work on code compliance checking has been published so it has therefore been explained only briefly.

2.2.7 Lack of research in UK

A review of the various efforts in relation to automated building regulations compliance checking in different parts of the world has been described in section 2.2. It is observed that there has been limited progress in automated compliance checking development which has been going on since the 1960s. Countries like Singapore, United States, Australia, Norway and Finland have shown interest in this type of research and taken efforts accordingly. However so far in the UK, efforts related to automated building code compliance checking has been very limited.

Initial efforts included in this context were, RIBAE, who are the official publisher of UK building regulations in 2008, created an elemental view of the building regulations. This elemental view helps in understanding the impact of clauses on individual building objects and is maintained via a complex matrix showing building objects and their relationship to building

regulations clauses and the classification system UNICLASS. This effort highlighted the importance of authoring of building regulations keeping objects at the forefront. This work was further continued and extended resulting into the creation of National BIM Library by NBS in 2012.

The NBS National BIM Library contains thousands of generic BIM objects from leading UK and global manufacturers. BIM objects are construction product information presented in a 3D format. They are freely available and are authored by NBS technical experts. BIM objects are created to comply with the NBS BIM Object Standard, a global standard providing high quality BIM objects by providing a common data set to drive collaboration and consistency.

Another recent initiative was the creation of BIM Toolkit by NBS, which provides step-by-step help to define manage and validate responsibility for information development and delivery at each stage of the asset lifecycle. The BIM Toolkit project was initiated by HM Government's BIM Task Group and funded by Innovate UK. However as indicated above, there was no initiative in UK, which directly focuses on automated compliance checking of UK building regulations. Hence this research work is pivotal in that sense which directly focuses on developing a methodology for automated compliance checking of UK building regulations.

2.3 Strengths and weaknesses of various approaches

A detailed review of each rule checking system has been conducted and presented above. In this section to begin with a consolidated view or summary of all the different rule checking systems available is presented and explained (see Figure 2.3). A consolidated view has helped in understanding how these systems work, what are their strengths, weaknesses and what differentiates them from each other (Levy & Ellis, 2006; Silverman, 2005; Thomas, 2006).

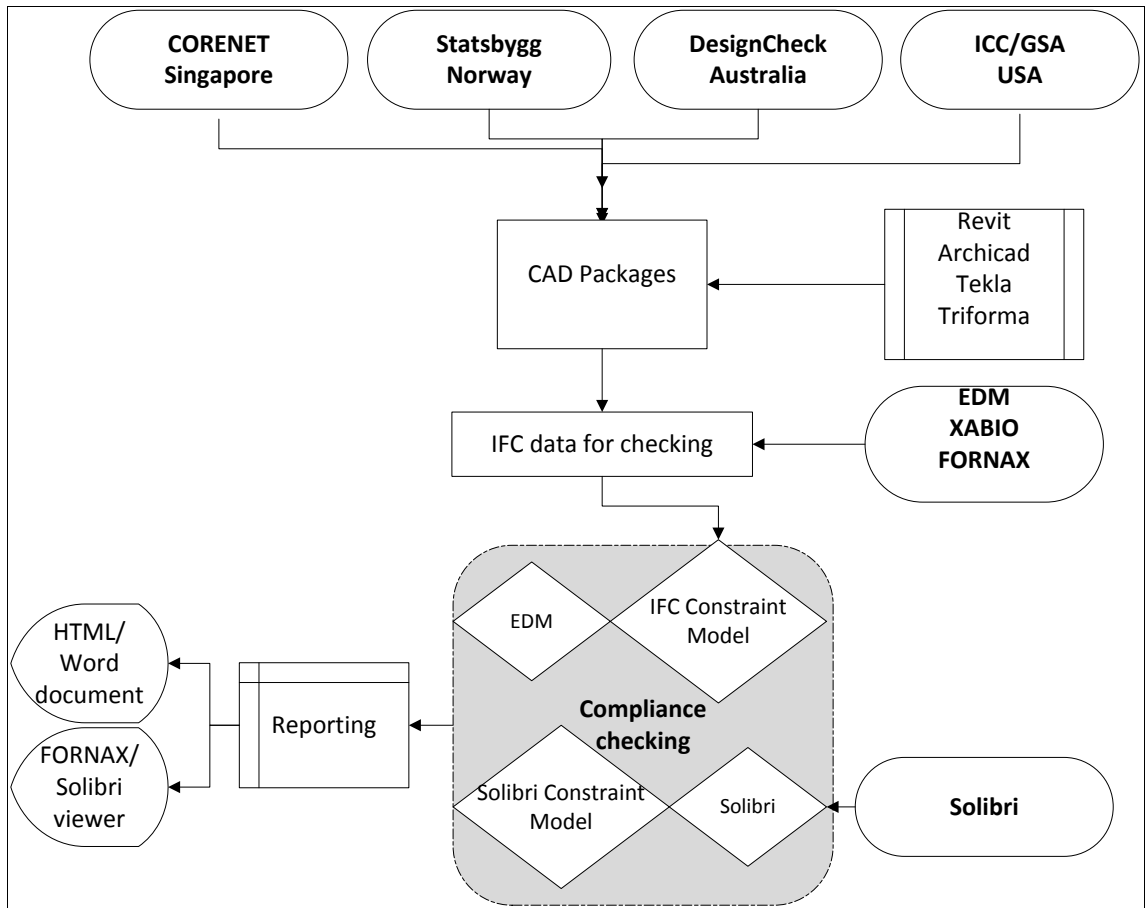

Figure 2.3: Review of implementation efforts undertaken on rule checking systems

Strengths

- As shown in figure 2.3 above, automated building regulations compliance checking systems use different CAD packages, such as Revit, Archicad, Tekla, and Triforma. However, they all are exported into IFC as a neutral data format for checking. All systems have advocated and used building information models over 2D drawings.
- Automated building regulations compliance checking systems use IFC as an interoperability standard. Although there are several open standards for building models, IFCs are the most comprehensive for the purpose of regulatory control. These IFCs are also widely adopted by the major CAD vendors and are generally accepted as the standard most likely to succeed (See, 2008).
- Almost all systems comprise additional object library which provides higher level of semantics. CORENET comprises an independent platform, FORNAX, along with the already existing EDM model checker. The EDM model checker is also part of rule checking systems such as DesignCheck and Statsbygg. The SmartCodes project from the ICC/GSA comprises SMC and XABIO as part of its rule checking system (Autodesk, 2008; Nawari, 2012).

- Through all these systems it is observed that the four main functionalities required for rule checking are as follows.
 - Building model preparation – extracting and deriving model view data for checking.
 - Rule interpretation – translating human written and readable rules into computer implementable ones.
 - Rule execution – applying rules to building models.
 - Reporting results - ideally graphically (contravening objects highlighted in the model) and with reference to the source rules.

This observation helps researchers, computer programmers, and building regulation authors in finalising the primary functionalities for automated building regulations compliance checking.

Weaknesses

- These systems do not focus on analysing country specific nature of building regulations and use of knowledge formalisation to extract data which is suitable for automated building regulations compliance checking.
- Based on the available published information about CORENET, Statsbygg, DesignCheck, ICC, and GSA, it is observed that they have typically addressed only certain aspects of their overall system.
- Also, almost all systems are still in the development stage and work is documented as ‘in progress’ (Evelyn & Fatt, 2004; Khemlani, 2005; Lau et al., 2004).
- It is concluded that most of the initiatives outlined above have focussed on creating object based rules and mapping the entities encapsulated within them to the international building model schema. However, this schema is designed to support the needs of an international user and takes little consideration of national semantics.
- Approach in all automated compliance checking systems, was to target a particular building clause and provide a relevant solution but it did not attempt to provide a solution which would be generic and applicable to all types of clauses.

2.4 Conclusion

Current work has presented many of these systems (CORENET, Statsbygg, DesignCheck, ICC, and GSA) in the form of reports and conference presentations. Based on their study through published literature and by understanding their strengths and weaknesses, a brief overview of these systems is presented in the table below 2.1

Table 2.1: Overview of rule checking systems

Country	Singapore	Australia	USA	Norway
Initiators	Construction and Real Estate Network	CSIRO and University of Sydney	US General Services Administration	Norwegian Construction Industry
Start of the initiative	1995-2000	1998	2000	1997
Platform use	FORNAX	EDM	SmartCodes	SMC
Target rules	Building code	Accessibility	Building code	Accessibility
Interoperability standard	IFC	IFC	IFC	IFC
Rule interpretation	Programming and predicate logic	Programming and object oriented interpretation	Predicate logic	Programming
Rules coded in	Computer code	Rule schema	SmartCode builder	Parametric tables
Rule check reporting	Graphical reporting	Graphical reporting	Graphical reporting	Graphical reporting

This review and analysis has initiated research aimed at developing an England and Wales building regulation specific building model schema. Mappings will be created between the developed schema and the IFC schema through the domain extension approach, ensuring interoperability and maintainability. Building authors will subsequently define rules in terms of the schema, ensuring comprehensibility and maintainability. Also, the nature of UK building regulations and their suitability will be analysed.

Chapter-3:

Industry Foundation Class Standards and Interoperability

3.1 Introduction

A consolidated view and detailed study of all the rule checking systems conducted in section 2.2 of chapter 2, indicated that automated compliance checking is about assessment of building designs with MCS based on configuration of objects, their relations and attributes (Lockley, Malsane, & Matthews, 2013). However, it was noticed that such software does not allow modification of a building design. A rule-based system applies rules, constraints or conditions to assess a proposed design, with results being classed as a 'pass', 'fail' or 'unknown' (Eastman et al., 2009). An unknown result occurs particularly in those cases where the required building regulation related data are incomplete or missing from the proposed building design file. To avoid such instances where data is not available or missing for checking purposes, a building data model preparation is a solution (Salama & El-Gohary, 2011). As per the work done in the last chapter, section 2.3, one of the four main functionalities required for rule checking is building model preparation, where the necessary information required for checking is prepared. This chapter describes the importance of preparation or authoring of a building model to make use of it in the UK automated compliance checking process. Also, it highlights the significance of IFC as an interoperability standard for building model vendors, as well as its use in automated compliance checking.

3.2 Background

Historically, development in information technology has been achieved with the help of advances in computer science. The purpose behind such development was to provide information to achieve set objectives more efficiently. This development is also reflected in the AEC industry (Froese, Han, & Alldritt, 2007). However, the AEC industry has a poor reputation for the manner in which its organizations and individuals adopt technological advances. For several years, the AEC industry has suffered from data ambiguities and communication lapses due to a relatively slow pace of adapting and exploiting information technology among designers and builders. While in nearly all sectors computers are responsible for increased productivity, construction productivity has seen a decline (Yan & Damien, 2008). To rectify problem such as data ambiguities and communication lapses, use of BIM is a solution, but so far in the AEC industry its utilisation has largely been limited to specific aspects of design visualization (Brandon & Kocaturk, 2008). Industries such as aerospace and automobile manufacturing have effectively used information technology to transform their ways of doing business. Similar to CATIA, a three-dimensional computer-aided design system that revolutionized airplane design, BIM has the potential to radically transform the way building designs are created, communicated and constructed (Foster, 2010). Similarly, BIM technology has the potential to help in automated compliance checking due to its ability to communicate building design more effectively (Succar, 2009).

3.3 Technological development/Development of CAD Tools

Over the past 10 years, design tools in the AEC industry have been improved from 2D modelling to 3D modelling, a situation that is encouraging in terms of the uptake of BIM (Greenwood et al., 2010).

3.3.1 The adoption of CAD

At first the technology of CAD was not as popular as it is nowadays. However, with the popularization of personal computers, the use of CAD became commonplace. During the 1970s and 1980s, two-dimensional (2D) computer aided design was developed and deployed by the ‘early adopters’ for construction design practices. By the end of the 1990s, 2D CAD was used in the majority of construction design activities and 3D design systems were available, although their use was limited (Greenwood et al., 2010; Yan & Damien, 2008).

One of the main reasons for the resistance to the use of 3D CAD in construction was the lack of perceived benefits. Essentially, this generation of software tool was drawing-oriented, i.e. the underlying representation in the tools was graphical (in terms of lines, arcs, points, etc.). For instance, a door represented in this way would therefore ‘behave’ like a series of graphical objects and not a door. For example, changing the opening width of the door meant making a line or arc shorter or longer. Whilst this was acceptable in 2D CAD (being no different to a traditional paper-based drawing procedure), in 3D CAD the amount of graphical change required was significantly greater. Thus, although 3D CAD brought great potential benefits (such as clash detection and visualisation) the overheads associated with the authoring of models rendered these benefits too costly. The end result was that most design practices used 3D for presentational purposes and disposed of the model once this was complete in favour of traditional 2D drawings (Azhar, Brown, & Farooqui, 2009; Lockley et al., 2013).

The initial response of CAD vendors to resolve this was *parametric object design*: rather than the user having to define the lines and arcs of the door they would be automatically generated from a set of parameters, such as height and width. As these parameters were altered, so were the resulting graphical representations. This approach effectively accelerated the process of authoring the graphical representation of the building, but essentially the resulting model was still a graphics-oriented model designed to produce output as drawings. The development of object oriented CAD resulted in BIM (Greenwood et al., 2010; Krygiel & Nies, 2008).

Traditional construction processes (with CAD participation) involve numerous documents at different stages maintained separately, resulting in overlap and inconsistency of information. Various project participants store information at several locations without sharing with other participants, making building design and its execution a complex process and resulting in the

late delivery of projects. The BIM concept was introduced to tackle this issue; it was about providing a shared podium which can hold information, including building regulations. BIM is expected to drive the construction industry towards a “model based” process and gradually move the industry away from a “2D Based” process (Foster, 2010).

3.3.2 Building Information Modelling

In the AEC industry, there is a misconception by some that BIM is only a piece of software. It is partly due to inadequate knowledge about BIM and partly due to aggressive marketing strategies of some software vendors, selling their piece of software as BIM software. Although software is a necessary part of the process, it is much more than an application. “Building Information Modelling is defined as the creation and use of coordinated, consistent, computable information about a building project in design-parametric information used for design decision making, production of high quality construction documents, prediction of building performance, cost estimating, and construction planning” (Krygiel & Nies, 2008).

BIM is interpreted differently by project stakeholders, but more commonly it gets associated with 3D graphical modelling of an architectural design. However, any piece of information related to a project can be considered BIM and it needs not to represent geometry all the time (Hamil, 2011). In fact, the actual start point of BIM is the client requirements or project brief; geometry comes later in the scenario in the form of floor plans, elevations and 3D views. As compared to 3D modelling, BIM is a powerful technology. It possesses all the functions of 3D CAD. BIM has an advantage over 3D CAD systems, as it stores information in the form of a collection of objects with associated properties. While 3D CAD can be described as a collection of points, lines, 2D shapes and 3D volumes, the BIM concept comprises geometric entities which have symbolic or abstract significance, as well as quantitative or qualitative data. BIM is fully acknowledged by architects for its versatility in developing design solutions and 3D visualizations. However, so far it is not well recognised as a construction tool which can be used by various stakeholders for different objectives, such as generating costs and scheduling savings etc. (Beetz, 2009; Foster, 2010; Niemeijer et al., 2009).

A BIM methodology seeks to add new or additional layers of information by allowing new methods of data exchange and communication amongst all stakeholders in a project. This can be the design team, builders and owners. Each of these teams needs a methodology with which to share information about a project in greater quantities and more efficiently than their current method (Dix, 2009). For any project, BIM acts as a podium which can hold information related to ductwork, electrical installation, fire protection, occupancy, energy consumption, CO2 emissions or any information that needs to be collected regarding a site or building. This collection of information can be fed along with geometry into a BIM authoring tool to enhance

the model. Similarly, for automated compliance checking purposes it is expected that building regulation specific data should be held by BIM. This data can be fed using geometry into building models using BIM authoring tools (Hamil, 2011). The goal of a BIM methodology is to allow an overall view of the building or project by including everything in a single-source model (Eastman et al., 2008). However, at present the authoring tools may not be capable of feeding all the required building regulation related data.

3.3.3 Open BIM Standards

Different CAD packages have their own internal BIM products. The number of such BIM products in the market is increasing due to its popularity. As these BIMs are owned by different proprietors, they all store information in their respective proprietor's format (Bailey, Brodtkin, Hainsworth, Morrow, & Simpson, 2008). This leads to compatibility issues and data sharing difficulties among these models. This issue of interoperability has led to the formation of numerous data standards like IFC, MVD, IDM, IFD, COBie, BCF, OGC, gbXML, BIMXML, DWF etc. (Niemeijer et al., 2009). However, the benefits of BIM will materialize only through the sharing of information across organizations, departments, IT systems and databases. To achieve the full benefits, the BIM standards is key to facilitating this cost-effectively and without relying on any particular product or vendor specific file formats (Conover, 2009; Niemeijer et al., 2009; Solibri, 1999).

- IFC-Industry Foundation Classes, the data model specification for building information modelling and data exchange. It is elaborated extensively in section 3.4.
- MVD-Model View Definition, the specification for subsets of all available BIM data to serve a stated purpose or process.
- IDM-Information Delivery Manual, the business case specification for exchange of BIM data, includes end user Exchange Requirements (ERs).
- IFD-buildingSMART Data Dictionary (International Framework for Dictionaries), a catalogue of common industry concepts rationalizing varied terminology, due to language, market, or professional idioms, for the same concept.
- COBie-Construction Operations Building Information Exchange, an information exchange specification for capturing BIM data related to building lifecycle management.
- BCF-BIM Collaboration Format, an XML schema that encodes messages to enable workflow communication between different BIM (Building Information Modeling) software tools.
- gbXML-Green Building XML, a file format schema for exchanging BIM data for building energy performance simulation and analysis.

- BIMXML-an XML schema developed to represent a simplified subset of BIM data for web services.
- PDF-Portable Document Format, originally developed by Adobe for the electronic exchange of any printable document.
- DWF/DWFX-Design Web Format, originally developed by Autodesk, as a PDF alternative for CAD data/documentation.

A true, non-proprietary interoperability data standard are key to the long and short term success of the building industry as it moves forward with BIM processes and technology. Open BIM standards as listed above, help in building detailed models; deliver accurate products that can be used during commissioning such as automated compliance checking. Further to ensure facility management throughout the life of the facility and to deliver high performance, carbon neutral, and net zero energy based facilities.

3.4 Industry foundation class standard

The IFC system is a data representation standard and file format used to define architectural and construction-related CAD graphic data as 3D real-world objects. Its main purpose is to provide architects and engineers with the ability to exchange data between CAD tools, cost estimation systems and other construction-related applications. IFC provides a set of definitions for all object element types encountered in the building industry and a text-based structure for storing such definitions in a data file (Young, Jones, & Bernstein, 2007).

IFC is known by most professionals simply as a data model developed to facilitate interoperability in the building industry. IFC was developed by BuildingSMART (earlier called IAI), located in different parts of the world. It was developed over several years with regular releases of new versions. Its first version was released in 1997 and the latest version is the seventh released in 2003 as IFC 2X2. IAI has 14 chapters in 19 countries and 650 members. IFC model development has been an ongoing process for several years, undertaken by the Model Support Group of the IAI. Each subsequent version adds capabilities to represent more entities and more relationships related to a building's lifecycle (BuildingSMART, 2008; Khemlani, 2004; Kiviniemi, 1999).

The existing IFC schemas have defined many universal AEC objects for the use of AEC applications in architectural design, cost estimation, building service design, construction, and facility management. The IFC model represents not just tangible components such as walls, doors, beams, ceilings, furniture, etc., but also more abstract concepts such as schedules, activities, space organizations, construction costs, etc., in the form of entities. All these entities, i.e. IFC wall, can have a number of properties, such as name, geometry, materials, finishes, relationships, etc. (Khemlani, 2004; Kiviniemi, 1999)

3.4.1 IFC layering structure and domain knowledge

The IFC model has four different layers, as follows: 1) core layer; 2) resource layer; 3) interoperability layer; and 4) domain layer. Each layer has several diverse categories and it is within each category or schema that the individual entity is defined. There are a total of 623 different kinds of entities, components and concepts. The modular design of the overall architecture (see Figure 3.1) is intended to make the model easier to maintain and grow, to allow lower level entities to be reused in higher level definitions. The layering system is designed in such a way that an entity at a given level can only be referenced to the same level or lower level entity (Eastman et al., 2009; Kiviniemi, 1999).

Resource layer: This layer contains categories of entities representing basic properties, such as geometry, material, quantity, measurement, date, time, and cost, and they are not specific to buildings. They function as resources that are used in defining the properties of entities in the upper layer.

Core layer: This layer has abstract concepts that are used to define entities in the higher layers, i.e. KERNEL Schema, a product extension schema.

Interoperability layer: This layer has entity categories that are commonly used and shared between multiple building constructions and facility management applications. Most of the common building elements/entities, such as beam, wall, door, column, etc., would be defined in this layer.

Domain layer: This layer is at the highest level and contains entity definitions for concepts specific to individual domains, such as architecture, structural engineering, facility management and so on (Khemlani, 2004).

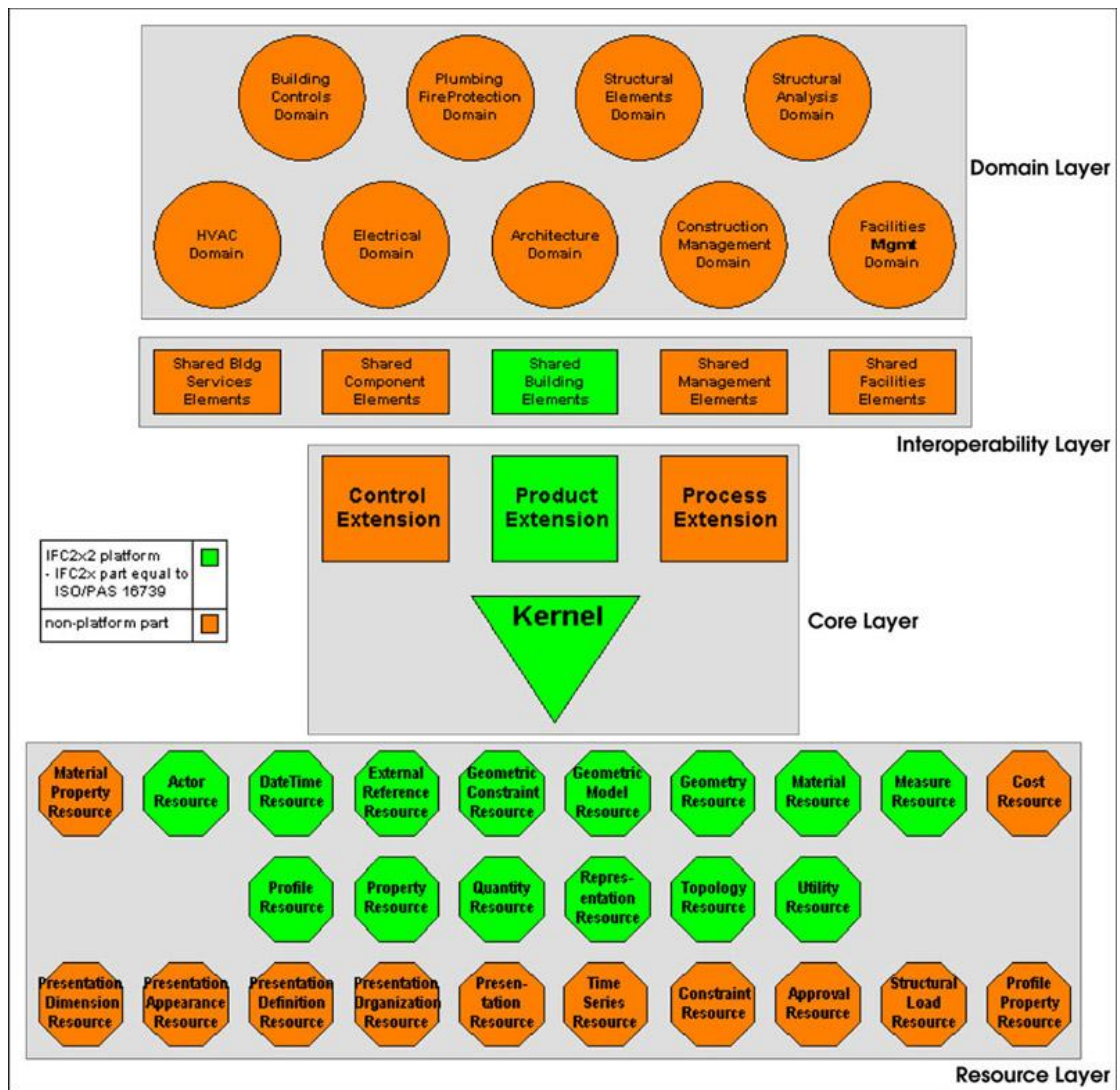

Figure 3.1: The overall architecture of the IFC model, showing the four different layers and the categories within each layer.

3.5 IFC standards for interoperability

Data interoperability is all about sharing information between different stakeholders involved in a project and software applications which are useful for design, construction, procurement, maintenance and operations. To transfer data between software applications, BuildingSMART has developed a common data schema. This data schema has the capability to hold interdisciplinary building information which has been used throughout the lifecycle of a project. This data schema format is named IFC (Sanguinetti, Eastman, & Augenbroe, 2009).

IFCs are an ISO-certified standard used to read information from BIM. IFC is unique as it is one of the few data exchange standards that the building industry has which does not only read and understand geometry, but also most CAD packages are compatible with it. Data exchange is possible for all major CAD applications because of IFC. Also, implementation of the IFC standard is possible as it is an open standard compared to the other closed and carefully

protected standards of CAD software manufacturers (Niemeijer et al., 2009). The IFC format is widely accepted; the most stable and has the capability to store semantic information.

IFCs add a common language for transferring information between different BIM applications while maintaining the meaning of different pieces of information in the transfer. This reduces the need for remodelling the same building in each different application. It also adds transparency to the process (Ding et al., 2006; Eastman et al., 2009; Holzer, 2009). IFC standard has been developed for consistent data representation of building information which can be exchanged between different AEC software applications. IFC has been developed in such a way that it provides broad general definitions of objects and significant attribute data. IFC has been designed to address all buildings related information, over the whole building lifecycle, from feasibility, planning to facility management (Eastman et al., 2008).

IFC is an open exchange format, as mentioned in section 3.4 that captures building information; it can be used by commercial building model based applications to exchange information with each other. For information exchange to take place it requires applications to be 'IFC-compliant', which means capable of importing and exporting IFC files. The IFC model specification is in the public domain and accessible to everyone, so developers can work with it and build the necessary IFC import and export capabilities. What this essentially means is that data has to be mapped between internal representation and the IFC representation (Woodbury, Burrow, Drogemuller, & Datta, 2000).

3.6 CAD exports into Industry Foundation Classes

IFC specification data files describing a building design contain rich sets of class definitions which represent various kinds of building objects. The hierarchy, properties and behaviours of these building objects are also specified in the IFC model. Present software applications, like Autodesk Revit, Graphisoft, ArchiCAD, Gehry Technologies - digital project designer, Vectorworks Architect, etc., can help to create building models. IAI's IFC has been implemented in several such AEC CAD packages and can consistently export valid IFC data files describing building model information (Yang & Xiang, 2001). However, when such models get exported into an IFC file, it cannot represent all the data. This results in data loss, part of which at times is essential from an automated building regulation compliance checking point of view. Software vendors are partly responsible for this particular problem because they are not fully IFC compliant. They need to find a solution whereby building models, when they get exported as an interoperability standard, should be able to represent all the information in the IFC files. This is why building regulation related information needs to be modelled with reference to the IFC standards.

To represent 3D CAD objects of building designs in an automated code checking process, IFC and its compliant information representations may be the most suitable models in terms of their standardisation, unambiguity, consistency and completeness of description of building designs. However, to make IFC files suitable for UK automated compliance checking, there is a need to author building models by feeding information particularly related to England and Wales building regulations (Bazjanac, 2002).

3.7 A paradigm shift

During the 1990s, computer scientists were making a paradigm shift in the way software was designed and authored. This involved moving away from a functional or procedural way of conceiving software to an object-oriented paradigm. Object-oriented programming required software engineers to construct their systems in terms of the real world objects that were involved in the problem to be solved (K. Lee, 2008). This shift in focus was intended to lead to more stable and maintainable software solutions that could be understood by domain experts who were intended to use the systems. Accordingly, construction industry researchers began to adopt the OBJECT ORIENTED approach to software design which resulted in several research prototypes (Stumpf, Ganeshan, Chin, & Liu, 1996). By the mid 1990s, the major CAD vendors were adopting this approach. However, it became apparent that building designs comprised thousands of different types of real world objects and that it was a task beyond any individual company to create computer models for all of these. There was a need for international standardisation for objects in building models and this led to the beginning of the development of the IFCs. It is important to note that this initiative to develop object and product models was not unique to the construction industry; rather it was part of an international initiative – the STEP model data- for all sectors of industry (Pratt, 2001). This pan-industry initiative initially focussed on developing a modelling language (EXPRESS) and file exchange format. These were the cornerstones of the current IF implementation. These steps enabled the next phase of development, namely generic resources or libraries that could be shared across all sectors to avoid duplication and accelerate development (Gray, Kulkarni, & Paton, 1992).

3.8 Conclusion

Following on the literature review about the growth of BIMs and IFC standards, the following points are concluded:

- At present, although the AEC industry has moved from using data in 2D CAD format to BIM data, there is a need to focus on the process of building model authoring by the design team to incorporate more and more information into building models.

- Currently there is no single software application which can claim to have the capability to fully populate data in a building model. This situation is further aggravated by the fact that there is an issue of model ownership and liability in model authoring. At present the focus of building model authors is largely on visualisation rather than building information and they are partly helpless to make models more semantically rich due to software applications' incapability to allow the same.
- As a result, current BIMs are not semantically detailed enough for use in the automated building regulation compliance checking process. Thus, to extend this information into building models or to make more building information available for the compliance checking process, an IFC-compliant England and Wales building regulation specific object model needs to be developed.
- IFC standards act as international open standards for interoperability as they focus on universal standards. The existing IFC model has defined many universal AEC objects for use with AEC applications in architectural design, cost estimation, building service design, construction, and facility management (Yang & Xiang Li). This indicates that the IFC data model is rich in its semantic content. However, it does not represent entities or attributes which are important in the local context of UK automated compliance checking. It has a complex hierarchical structure and relations established between objects are not necessarily suitable for the automated compliance checking needs.
- The review suggests that there is awareness that international CAD tools should be employed to author the majority of building models in the form of elements, materials, geometry, etc., and an extension programme is a must for author data which is missing. There are several open standards for building models but our research to date has suggested that the most comprehensive, for the purpose of regulatory control, are the IFCs. Other standards such as the City Geography Mark-up Language (CityGML) and Green Building Extensible Mark-up Language (GBXML) are targeted at a specific use and do not model the breadth of concepts required. The IFCs are also widely adopted by the major CAD vendors and are generally accepted as the standard most likely to succeed.
- In the context of automated compliance checking, model authors are not focussing on adding the required England and Wales building regulation specific information as it is not the established practice yet. If they want to, software applications must be developed that help them to do so. Model authors also need help with producing formalised data from the building regulations that are readily available so that they can include them in their building models.

Chapter-4:

Theoretical Context for Object Based Model Development

4.1 Introduction

A historical review of various rule checking approaches illustrates the limitations of rule checking applications, specifically their inability to check all types of building regulations. Hence it was important to make a clear distinction between what can be done in the rule checking software and what must be done by skilled professionals. In the context of UK automated building regulations compliance checking to classify building regulations as suitable or unsuitable (Vanier, 1989), a clause filter system was developed as part of this research. It is explained in detail in this chapter.

The preceding chapter reviewed various automated rule checking approaches and described the considerable gap between what the construction industry expects from automated compliance checking and what code checking research work offers to date (Jaeger & Harelik, 1985; Yang & Xiang, 2001). To bridge the gap and achieve the expected results, a new approach was required for the development of an IFC-compliant common and sharable building regulation object data representation model.

From a UK automated compliance checking perspective, to make building design information available at a more mature level or to make necessary information about building designs directly available, an IFC based building data representation model needed to be developed. This IFC based building representation model needed to offer new building objects and attributes, specific to England and Wales building regulations, into the existing international IFC model to facilitate the automated compliance checking procedure. To develop such a UK building regulation specific object model for checking, fire safety (Part B1) regulations were selected as the sample data (Neuman, 2007; RIBAEnterprises, 2006). Why and how such a data sample of fire safety regulations was chosen is explained in this chapter in section 4.3. Furthermore, as part of the building regulation specific object model development process, the concept of knowledge formalisation is introduced here. A brief overview of modelling types is explained before going into the development details of the object data model. The UK building regulations object data model was developed using a modelling language, Express-G, which is described here.

4.2 Background

The building regulations comprise guidelines and provisions for the design of buildings, representing complex and subjective information. They possess certain major characteristics as mentioned in section 2.1. To check compliance of building designs against such provisions automatically, it was necessary to carry out classification, as mentioned in section 2.4, to find out which building regulations should be considered for automated compliance checking and which should be performed manually. This context gave rise to the need for classification of the

UK building regulations. The need for classifying the building regulations was further substantiated by the characteristics mentioned in section 2.1 which typify the UK building regulations.

As mentioned in section 3.8, a new approach was required for developing an IFC compliant UK building regulation specific object data model and it began with knowledge formalisation. Knowledge formalisation provided the foundation for developing a data model by making formalised knowledge of the UK fire safety building regulations available. Using this body of work, the IFC compliant UK building regulation specific object model was developed.

The basic aim of knowledge formalisation in the context of the UK automated compliance checking was to interpret a body of building regulation knowledge and convert it into a computer application processable format, in such a manner that the implementation could be validated as being consistent with the original written knowledge (Hjelseth, 2009). This concept is further explained in Chapter 5 in section 5.5. The formalisation of building regulations in the UK context was achieved through three steps, as follows:

- 1) Selection of appropriate building regulation section belonging to a particular domain (e.g. Fire Safety clauses for the UK dwelling houses).
- 2) Classifying building regulation clauses into computer interpretable or not (declarative or informative) using a filter system.
- 3) Decomposition of the declarative and informative clause categories to extract semantics and to form pseudo codes.

In this context, where clauses need to be categorised based on their suitability for automated compliance checking, a filtering system was designed and it is explained in detail in section 4.6 below.

4.3 Selection of a data sample

The knowledge formalisation process commenced by focusing on a particular part of the building regulations (fire safety clauses for dwelling-houses). It was difficult to cover all kinds of codes at once for automated compliance checking, as the codes are bulky and complex. UK building regulations are divided into 14 Approved Documents and each approved document has many sections and subsections. The UK Approved Document Part B1-Fire Safety was considered part of the sampling process as a representative data sample for the knowledge formalisation (Bryman, 2004b). Fire safety requirements are generally acknowledged to be the most complex and difficult to interpret. More about how this data sample was chosen and the use of a sampling technique is provided in the next section.

The selection of data was followed by application of a filter system to determine whether the regulations were suitable for automated checking or not. Only suitable provisions filtered from the system were taken into consideration for automated checking. Every possible entity featured in the measurable regulations was identified and extracted. This formalisation of measurable regulations data continued with extracting the facts (criterion data) and rules from the building codes (Yang & Xu, 2004).

4.4 Use of an appropriate sampling method

Before going into the process of knowledge formalisation, it was important to decide on a sampling method so that it could be used to select the appropriate UK building regulation sample data. The data collection and sampling process was one of the most important milestones in this research. The sampling technique used was a very complex process and at times it led to a lack of clarity in the results. The sample had to be selected in such a way that the sample would represent the whole population with maximum accuracy and efficiency (Marshall, 1996). Also, in order to achieve valid inferences about the collected data, it was necessary to select the right sample size (Marshall, 1996; Trochim, 2006).

The main aim of sample size selection for quantitative research is to have the ability to generalize and make inferences from the sample about the entire population. In qualitative research, however, the main aim of sample size selection is to answer the research question adequately and efficiently. A single figure sample size may be sufficient to analyse and do a detailed study for a simple research question. For complex research questions, however, multiple samples and sampling techniques may be required. As a study progresses, the study gets more clarity, reducing the emergence of new categories, themes or explanations from the data and focusing more on important subjects which are necessary for the research. This is termed 'data saturation' and it helps to narrow down the research question and stop confusion related to various other data elements. Unlike the quantitative approach where the research design has a stepwise approach, the qualitative research approach requires a flexible research methodology which allows a stepwise as well as cyclic approach to sampling, data collection, analysis and interpretation (Marshall, 1996). This implies that qualitative research involves repetitive study of different phases, like sampling, data collection, etc., in the research. There are three broad approaches to selecting a sample for a qualitative study – convenience sampling, judgement sampling and theoretical sampling.

4.4.1 Convenience sampling

As the name suggests, this involves techniques that make the selection of the most easily accessible, relevant data for the research. It is the least costly in terms of time, effort and money for the researcher but at the same time it offers less reliable and poorer quality outcomes. A

justified and rational sampling of data can be achieved by a more thoughtful approach rather than just the selection of an easily accessible and convenient sample (Marshall, 1996; Trochim, 2006).

4.4.2 Judgement sampling

Judgement sampling is considered the most common and useful technique because in this technique, the researcher selects the most productive sample possible to answer the research question. It also involves the researcher developing a strategy, methodology or framework of the variables based on evidence and a literature study. This might include variables such as age and gender but it has more intellectuality (Bryman, 2004a; Cresswell, 2003).

4.4.3 Theoretical sampling

Theoretical sampling is the building and generating of theories from the study of a sample collected and then selecting new samples to examine and validate the theory. It is a technique used for qualitative research and necessitates interpretation (Marshall, 1996).

The UK Approved Document Part B1-Fire Safety was considered part of the sampling process. It acted as representative data to extract semantics for the data model development. For testing condition small sections of the building code with fire requirements is targeted, and as shown in figure 4.1 below, using filters at different stages suitable data is extracted. Fire safety requirements are generally acknowledged to be the most complex and difficult to interpret.

4.5 Overview of the selected data sample

The UK Approved Document Fire Safety Part B was selected using the judgement sampling technique as a representative data sample; Part B is divided into Volume B1 and Volume B2, having altogether 11+18 different sections. Fire Safety Volume B1 has 137 clauses and Volume B2 has 445 clauses (see Figure 4.1). Fire Safety Part B is one of a series that has been approved and issued by The Secretary of State for the purpose of providing practical guidance with respect to the requirements. Fire Safety Volume-B1 deals solely with dwellinghouses while Volume B2 deals with other types of building. The provisions set out in this approved document deal with different aspects of fire safety in the context of building design, and appropriate guidance to each of these aspects is provided separately in Part-B. Some of the significant aims of this guidance are as follows:

- B1 – To ensure satisfactory provision of means of early warning and satisfactory standards of means of escape during fire hazards.
- B2 – To ensure internal linings are protected from fire spread.

- B3 – To ensure the stability of buildings in the event of fire.
- B4 – To ensure external walls and roofs have adequate resistance to fire spread.
- B5 – To ensure satisfactory access for fire appliances to buildings.

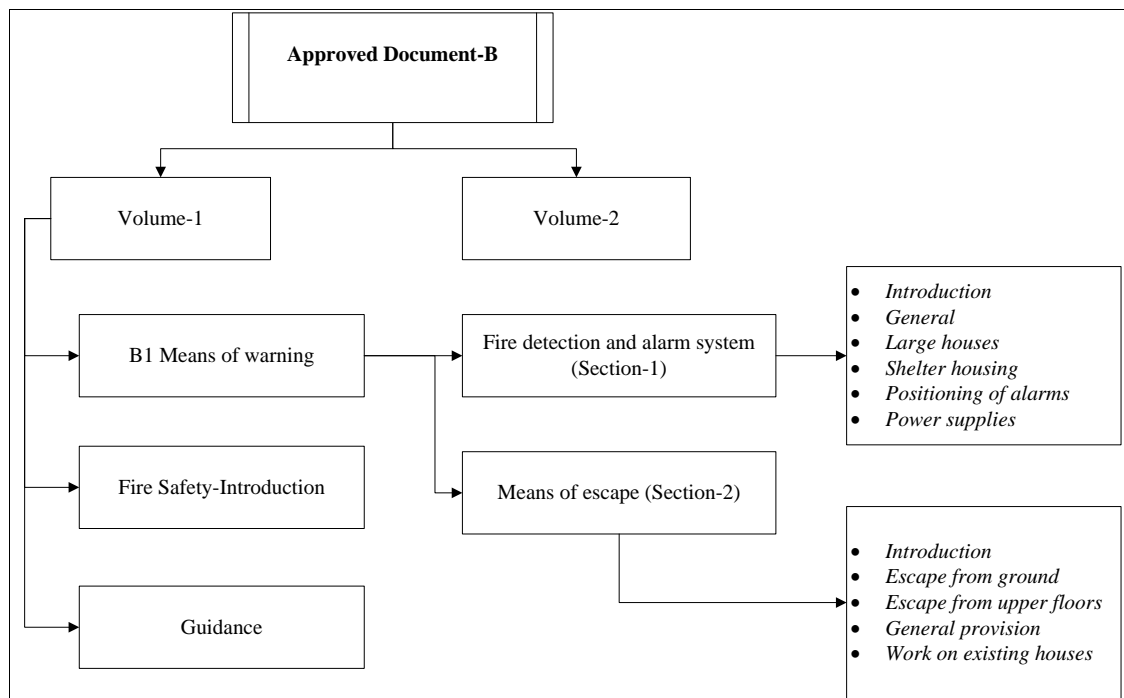

Figure 4.1: Overview of Fire Safety Part-B, Volumes B1 and B2

The guidance has been clearly described in various sections for different requirements; many of the provisions are closely linked to each other. There is a close link between the provisions for means of escape (B1) and the control of fire growth (B2). The document has been designed in such a way that the guidance as a whole should be considered a package aimed at achieving an acceptable standard of fire safety. Thus, this overview shows that the sample data size considered for knowledge formalisation was adequate and acted as a representative of the whole data. This data sample was used for the application of a filter system.

4.6 Use of the data filter system

Fire Safety Volume-B1 was selected for knowledge formalisation using judgement sampling. After that a consistent strategy was required for classifying the building regulations of the selected part B to make them suitable for checking. This resulted in the development of a data filtering system that was applicable to any part of the UK approved document.

A data filtering application is mainly about clause data sorting, clause classification on the basis of their nature and putting them into different categories for further use. The application in this case had three data filters: filter one; filter two and filter three (see Figure 4.2). All three filters

were used for suitable data extraction or classification of clauses for further use. The three data filters had different responsibilities to perform and these will be described further.

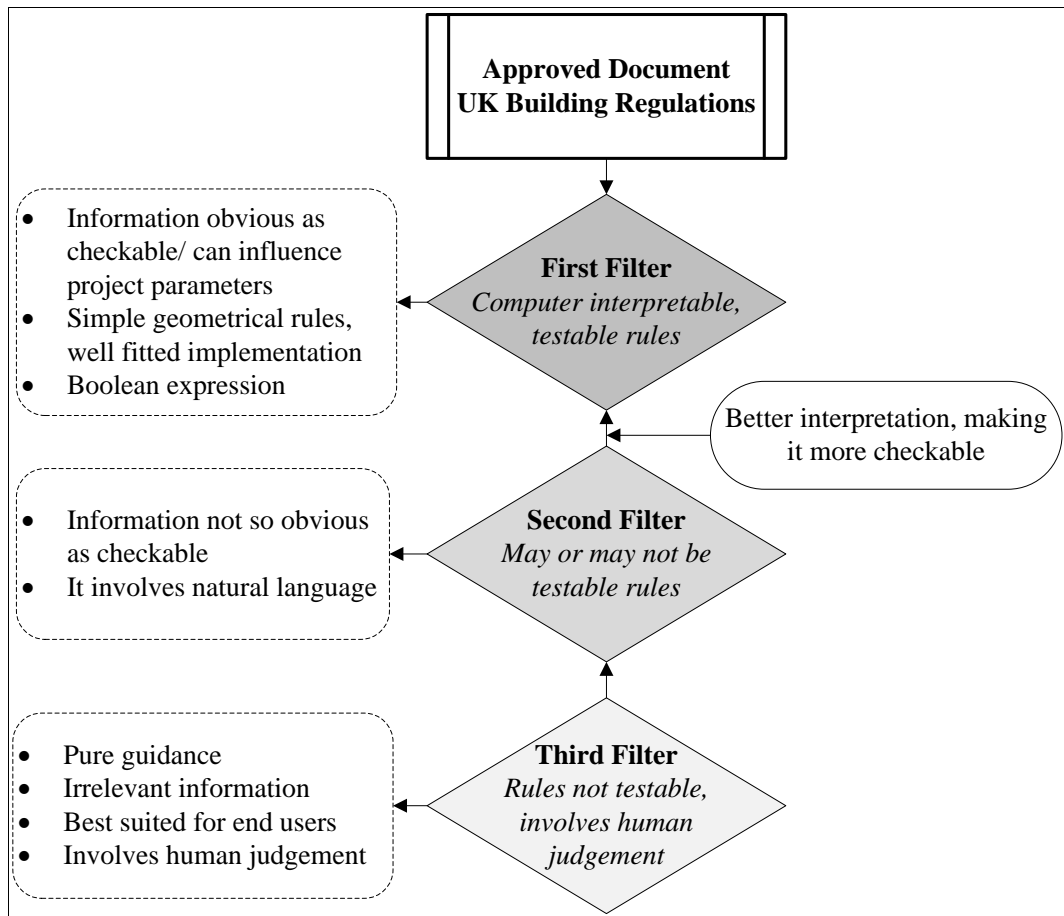

Figure 4.2: Information filter system applicable to clauses

4.6.1 Filter one

The UK approved document consists of clauses and by nature these clauses vary from one another. Some of them are measurable and readily checkable as they involve geometry and factual data. These clauses contain entities with certain attributes and that is why they are termed measurable. Such clauses could be extracted and put together in a category using filter one and this was its sole aim. Clauses extracted using filter one were termed ‘declarative clauses’ as they deliver a very direct meaning. Some of the information in part B appears very practical and realistically logical. Such data has a lot of value in terms of the influence on a whole building’s life cycle. Such data comes under declarative codes.

Declarative codes are short in length and can be reinterpreted easily into a form that can be automatically checked. This is one of the reasons why they are easy to convert into a form suitable for automated checking. Filter one was applied to all UK fire safety requirements and this acted as an effective starting point for the automation of codes. Using the data filtering

system and by applying filter one, 35 declarative clauses were extracted and used for the information model development.

Examples:

- Smoke alarms should not be fixed next to or directly above heaters or air conditioning outlets.
- Relative safety places should be provided on a route, e.g. a protected stairway within a reasonable travelling distance.
- There should be at least one smoke alarm on every storey of a dwelling house.

4.6.2 Filter two

A typical UK approved document has plenty of clauses which are not obviously checkable in their nature. They tend to be more subjective and do not project a direct meaning. They involve natural language and expertise is needed to understand their exact meaning and to turn them into checkable codes. Clauses extracted using filter two were termed ‘informative clauses’ as they possessed a lot of information relating to building regulations but did not deliver a very direct meaning. Fire regulation part B features a lot of data which is informative and explanatory. Sometimes having knowledge of such data helps in long term cost reduction and less maintenance work, but current regulatory authorities do not consider incorporation of such data into building models while checking for approvals.

From an automated code checking perspective, it was necessary to re-interpret existing codes into a form that could be automatically checked; not all informative codes could be represented in the same way. Some informative codes represented important information which could feature in the approval process but some of them represented information which was not so important and rather difficult to reinterpret. Informative codes are difficult to reinterpret into a form that can be automatically checked because extracting information for checking is not easy. Using the data filtering system and by applying filter two, 32 informative clauses were extracted and used for the information model development.

Examples:

- There should be provision for early warning of fire.
- There should be routes of sufficient number and capacity.
- Escape routes should be suitably located to enable persons to escape to a place of safety.
- There should be appropriate means of escape in case of fire from the building to a place of safety.

4.6.3 Filter three

The approved document is structured in such a way that data including some clauses is not suitable for checking, very subjective and involves human judgement to make meaning of it. On some occasions this type of data is pure guidance, mainly for end users, and does not feature in the actual checking criteria. Information provided in part B, but not necessarily all information, should be turned into ruleish or codeish or should be part of automated code checking, as 50% of such information is merely guidance and too subjective and descriptive.

The current manual building regulation checking method does not consider this sort of information as a basis to supervise building drawings or building works. This will always be useful as additional information but should not be mandatory. Using the data filtering system and by applying filter three, 60 clauses containing pure guidance were extracted and used for the information model development.

Examples:

Fires do not normally start in two different places in a building at the same time. Initially, a fire will create a hazard only in the part in which it starts and it is unlikely, at this stage, to involve a large area. The fire may subsequently spread to other parts of the building, usually along the circulation routes. The items that are the first to be ignited are often furnishings and other items not controlled by the Building Regulations. It is less likely that the fire will originate in the structure of the building itself and the risk of it originating accidentally in circulation areas is limited, provided that the combustible content of such areas is restricted.

4.7 Data modelling

An information system is a means to provide information required by an organization. Generically, an information system receives information, stores it in a descriptive form, processes it and makes it accessible at the need of the user. This information stored by the information system in a descriptive form using some sort of coding is called data and storing of this data on a physical media is termed a database. A database is primarily concerned with structured or formatted data; it possesses similar data patterns which indicate that it can be easily classified into categories or classes (see Figure 4.3). A data model is a primary tool for designing a database (Nazar & Bramer, 1997).

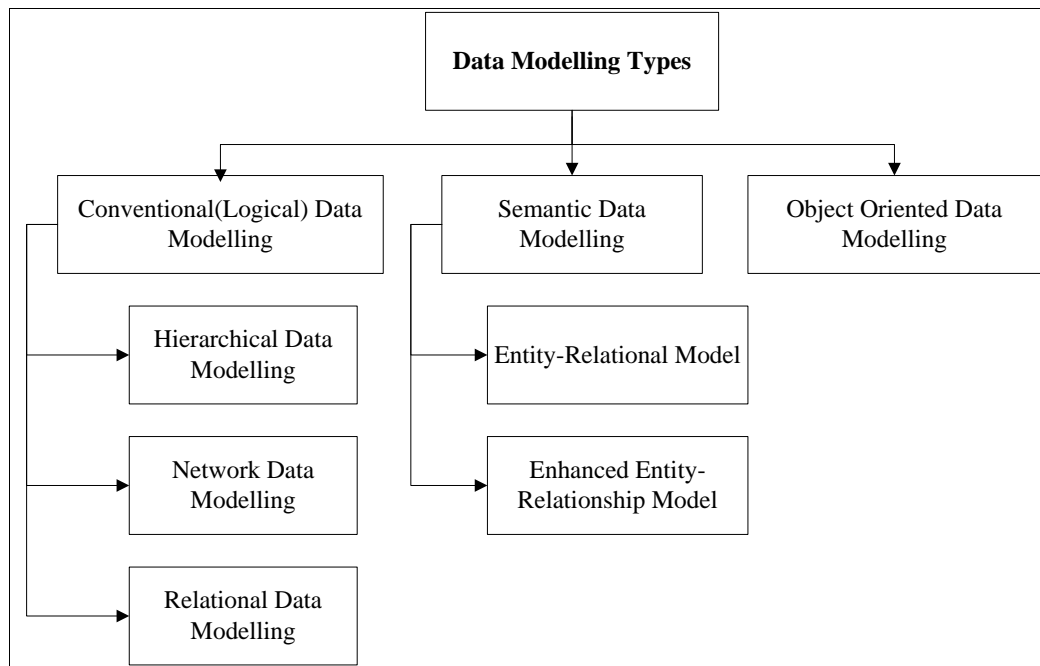

Figure 4.3: Data modelling types

4.7.1 Conceptual data modelling

Conceptual data modelling is about understanding data, descriptions of objects and their behaviour in the real world, and is an effort to capture their structured representation in the database. As mentioned by studies (Gray et al., 1992) since the early 1960s, conceptual data modelling has been an active area of research, leading to different data model proposals and eventually leading to a clearer understanding of the information modelling process(see Figure 4.3).

4.7.2 Classical data models

Classical data models fail to capture much of the semantics associated with data and hence are not suitable for conceptual data modelling. The hierarchical, network and relational data models are three of the most common and popular examples of a classical data model. However, in all three of these models, the fundamental modelling construction, record or relation does not contain an atomic semantic unit; as a result these models need extensive additional constraints to maintain semantic integrity of the database.

4.7.3 The hierarchical data model

The hierarchical data model, to represent entities or objects, possesses the concept of a record. A record is a collection of named fields to represent each individual object in the application environment. Additionally, the hierarchical data model allows one or more relationships in a tree like structure, where each record occurs at a specified hierarchical level.

4.7.4 The network data model

The network data model sets mechanism by which any owner record has one-to-many associations with a number of member records, thus allows a network of relationships.

4.7.5 The relational data model

The relational model is to describe a database as a collection of predicate variables, describing constraints but relation does not contain semantic unit. The relational model uses a single mechanism, a relation for modelling entities, to present association among entities. This leads to semantic overloading on the relation and results in difficulties for users determining the meaning and purpose of a relation.

Use of classical data models for conceptual data modelling is not sufficient and its deficiencies have triggered intense research work in the semantic data modelling area (Gray et al., 1992; Nazar & Bramer, 1997).

4.7.6 The semantic data model

The semantic data model, a conceptual data model type, aims to capture the meaning of data in a more or less formal way so that database design can become systematic and the database can behave intelligently. Semantic data modelling work has been inspired by knowledge representation research in artificial intelligence. Work on semantic data modelling started as early as 1963. Overtime there have been several prominent data model proposals which aim to capture more and more semantics of data. There have been several research based articles which explain semantic data model proposals. The earliest of such studies was conducted in 1976 (Gray et al., 1992; Kantardzic, 2003).

4.8 Need for a semantic model

As established through the literature review, the exported CAD information in IFC files is not rich enough for the use of building code compliance checking in an automated process. To extend this information or to make more design information available for the compliance checking process, an IFC-based building conceptual representation data model needed to be developed (Yang & Xiang, 2001; Yang & Xu, 2004) in the context of the UK fire safety regulations. It supplements UK building regulation specific building design objects and attributes into the existing IFC model to facilitate the automated compliance checking.

The IFC compliant building object representation model is defined in EXPRESS-G language. It is targeted to extend standard IFC specifications by using additional type objects and some entity attributes. One of the primary intentions of developing such an IFC compliant building

object model was to meet the particular requirements of the automated checking procedure, specifically for UK fire safety regulations.

As discussed in section 3.4, the IFC standards were used as an interoperability standard to represent 3D building design information. However, at present the standard IFC schema lacks additional building regulation specific attributes and rich sets of ‘propertyset’ attached to objectified classes. IFC does not allow capturing of high level semantics of building elements as required by code compliance checking. FORNAX, Solibri, and EDM are platforms designed to bridge the gap between IFC models and code checking requirements. When BIMs are exported into IFC based files to automatically check, the information needed in the BIM represented as a file is either absent or of poor quality/relevance in some cases; hence, a semantic model is a solution.

4.8.1 Supplementing additional entities

As established before, an IFC file often only represents the basic geometrical building information which can be modelled by a BIM application. This leads to the issue of a lack of significant data for automated compliance checking. That is why it is important to have a building model which is consistent with the rules to be checked, possessing required IFC entities and properties prior to derivation of extended information. (Bazjanac, 2002) points out that enriching a building model IFC schema with required information by defining and entering new attributes using ‘propertyset’ is a way forward. How to supplement such additional UK building regulation specific entities along with attributes is a challenging task. During the stage of building regulation knowledge formalisation, different entities and attributes emerged; these were used as additional attributes to extend the IFC model further. An IFC compliant model with additional attributes was necessary to meet the specific requirements of the automated checking process and to make more design parameters available directly for the automated process. Development of an IFC compliant model with interoperable and extensible features involved the extension of an existing IFC model, adding a new entity and entity attributes. As indicated above in section 4.7, the information model was defined using computer modelling language, Express-G, but to get this model executed it needed to be implemented in a programming environment so that it could represent real building data in CAD files.

4.9 Capabilities and significance of STEP model data and IAI

STEP model data and IAI are international communities which are working on the development of standardised representation models for products such as buildings. These communities are targeted at providing a mechanism for standardised representation, exchange and sharing of computer interpretable information about a product; a building in the case of AEC. Both use EXPRESS modelling language to describe and represent building information structures and

relationships. However, at present these STEP models are not completely information rich and they are evolving to a mature level to have the support of major AEC CAD vendors (Greenwood et al., 2010; Yang & Xiang, 2001; Yang & Xu, 2004).

IAI's IFC is an effective alternative to STEP model data as an interoperability standard due to its capability of having rich sets of class definition to represent various building related objects. Several AEC CAD packages can consistently export data into rich IFC data files describing a building design. To represent 3D-CAD objects of building designs for an automated regulation checking process, the IFC standard and its compliant information representation is the most suitable in terms of its standardisation, unambiguity, consistency and completeness of description of building designs (Yang & Xiang, 2001).

4.10 EXPRESS-G described as a modelling language

Information models describing products such as ships, steel frameworks and buildings have been developed using EXPRESS models. EXPRESS is a data definition language that has been used to define a schema for modelling building related products such as doors, windows, etc. Such a schema contains concepts which are formalised using entities, attributes, types, etc., and their hierarchical interrelations. Hierarchical linking amongst these formalised concepts (in the form of entities, types and attributes) can be established through relationship attributes (Beetz, 2009; Reuter, 1998; Schevers & Drogemuller, 2006).

EXPRESS is a graphical modelling language. This powerful data modelling language development started in the early 1980s much before Extensible Mark-up Language (XML) and Unified Modelling Language (UML). The language development started aimed at making it a flexible, extensible and scalable modelling language easy for human experts to read. EXPRESS-G is also a graphical modelling language and is directly related to the EXPRESS data definition language. It is used to identify object classes, to describe data attributes and to establish relationships between objects. EXPRESS-G was developed under the STEP model, which has been selected successfully in some industries. A limited number of model developers are aware of its existence and capabilities. IFC schemas have been extensively developed in EXPRESS-G. Everything that is drawn in EXPRESS-G can be defined in EXPRESS; however, not everything that can be defined in EXPRESS can be drawn in EXPRESS-G (Beetz, 2009).

- **EXPRESS and EXPRESS-G association**

This section of the thesis provides a basic description of EXPRESS-G notations and the representation techniques used for the development of the UK Building Regulation specific model. The data model is a graphical development easy for users to read, and represents the essence of building regulations. It is not a complete reference to the capabilities of EXPRESS-

G. It was developed as a subset of the EXPRESS language. With the help of EXPRESS-G editor, users can assemble a large data model using class objects and their relationships with other class objects (Reuter, 1998). A simple example of a class included in an EXPRESS schema is the class FireDetectionAlarmSystem.

- **Entities/Classes**

In semantic modelling, as mentioned in section 4.8, data is modelled in terms of atomic units called entities or objects. An ‘entity ‘can be loosely defined as a thing that exists and corresponds to real world objects, like building elements such as wall, door, window, etc. In a semantic data model, entities can be distinguished using unique designations and this is known as ‘object identity’. A class needs more information in terms of attributes to describe it fully. Once related specific information is modelled for describing one instance of a class, the specification can be generalised to cover all instances of the same class. Things in which we are interested are also known as classes. In Express-G modelling language, classes are represented in a rectangular box with solid lines enclosing the name of the class (see Figure 4.4). A class requires more information to describe it fully and this information can be provided using attributes.

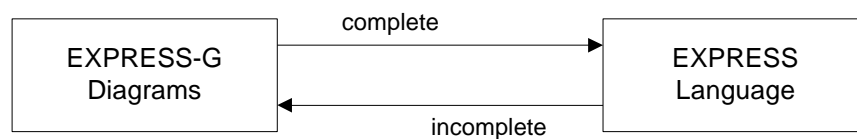

Figure4.4: Express/Express-G association

- **Entity types**

Entities representing real world objects share some common properties. For example, all dwellinghouses have properties like area, address, storeys, etc. Categorisation of such real world objects on the basis of shared common properties is termed ‘entity types’. The concept of entity type provides a powerful method of organising, simplifying, and condensing the information about groups of objects. Some authors have termed this ‘class’ in place of ‘entity types’.

- **Simple data types**

Simple data types are the smallest parts of EXPRESS-G, as they cannot be subdivided into anything smaller. A simple data type is shown as a rectangular box with a double vertical line at the right hand side of the box (see Table 4.1). The actual name of the data type is enclosed within the box.

Table 4.1: Various options of simple data types available

BINARY		A sequence of 1 and 0, e.g. 100101
BOOLEAN		True or false (equivalent to 1 or 0)
LOGICAL		True, false or unknown
STRING		A sequence of alphanumeric characters, e.g. 'Room'
NUMBER		Any number either integer or real, e.g. 16, 16.23
INTEGER		A whole number without decimals, e.g. 16
REAL		A rationale number including decimals, e.g. 16.23, 16.0

- **Attributes and relationships**

Everything which comes under the description of a class or everything that is related to a class is considered to be an attribute or a data member. This data attribute can be a simple data type as mentioned in the table 4.1, a constructed or defined data type or it can be another class.

Consider a class called FireDetectionAlarmSystem; this class describes a fire alarm, detector and sprinkler system. This class has attributes such as PowerSupplyType, Number and System Category. These attributes may be either mandatory or optional. Mandatory means whenever an instance of the class is used, a value of that attribute must be given. Optional means that a value may be given but it is not necessary on an instance of a class. Mandatory relations are shown by a solid line between classes and attributes. Optional relations are shown by a dashed line between classes and attributes. The name of the relation is written above the line. The circle shows the primary direction of the relation.

- **Relationships between classes**

Relationships exist between classes. While it is possible to represent relationships between classes in EXPRESS-G, it does not allow the use of spaces in a class name. In many instances, it feels necessary to use the same name for several relations that a class possess, but this is not allowed in EXPRESS and therefore should not be used in an EXPRESS-G model.

- **Cardinality and aggregation**

Relationships that exist within the information model can be either mandatory or optional. Cardinality is a term that describes a numeric quantity to the relationship. In the example below, the mandatory relation established suggests BuildingElement must have exactly one TotalLength whilst the optional relation identified suggests BuildingElement may have zero or one TotalVolume. EXPRESS-G allows greater than one numeric value for relations by providing various aggregation methods or aggregate data types (see Table 4.2). For example, a site may have zero, one or more legal descriptions and at least one boundary curve. Aggregations allowed are:

Table 4.2: Various Aggregations types available for data modelling.

ARRAY	A fixed size collection of things with order represented as A [1:?].
BAG	A collection of things with no order and allowed duplication represented as B[1:?].
LIST	A collection of things with order and no duplication represented as L [1:?].
SET	A collection of things with no order and no duplication represented as S [1:?].

The most frequently used aggregation will be SET and LIST. The FireDetectionAlarmSystem example shown uses SET which indicates that the FireAlarm relationship is unique but the elements may occur in any order. If the relationship was set LIST it means FireAlarm must occur in a particular order with each listed element being unique. The first character in square parentheses in an aggregation is the minimum possible value. The second character is the maximum possible value and may be either a number or the (?) character, which means indeterminate.

- **Supertype/Subtype relationship**

In EXPRESS-G, supertype-subtype relations are a special form due to its INHERITANCE capability nature. A class is described with general specifications but it can be expended by particular characteristics of subtypes. A subtype represents or inherits all the properties possessed by its supertype class object. However, each subtype may have additional attributes and a supertype/subtype relationship can be represented by a double thickness line.

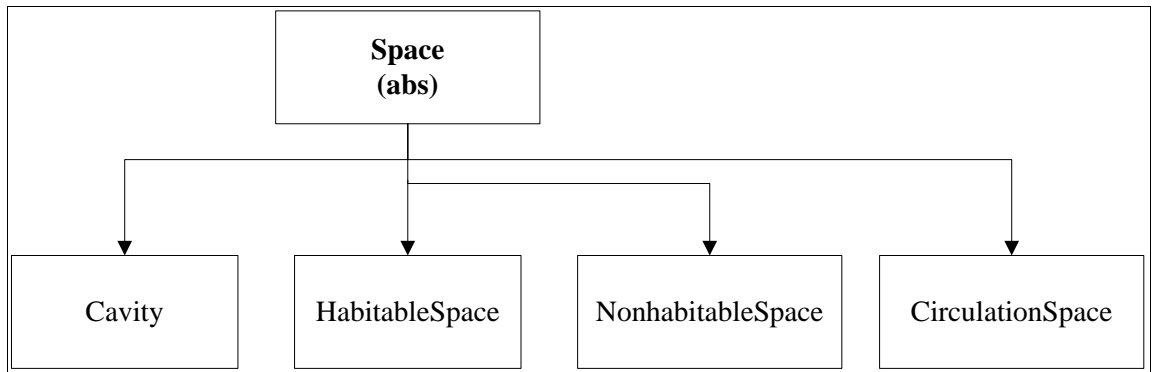

Figure 4.5: Entity Space, abstract supertype

To make the subtypes exclusive, for instance the Space entity may be a CirculationSpace, a HabitableSpace or a CavitySpace (see Figure 4.5); the number 1 is written at the branch of the relation. In the example, the term (ABS) is used with a Space entity to indicate that it is an abstract supertype. This means that it cannot exist in itself, only by virtue of its subtypes. The abstract supertype is a key as it not only allows attributes to be collected at a higher level within the data/information model but also inherits them to its subtypes.

- **Enumeration data type**

When an enumerated data type is attached as an attribute to an entity, it presents a possible value in the form of an enumerated list. The attribute will only take one value out of the enumerated list. It is shown as a rectangular box with dashed lines and a double vertical bar to the right. The name given to the enumeration is written in the box.

The example below (see Figure 4.6) shows an enumeration for the Cavity entity; it is enumerated as WallCavity, ExternalWallCavity, RoofCavity, FloorCavity and WallCladdingCavity.

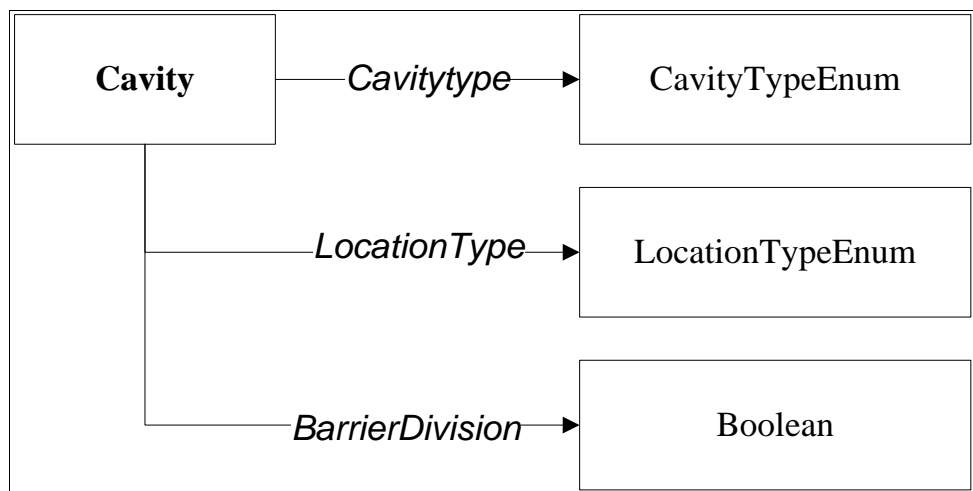

Figure 4.6: Cavity enumeration types and its use

- **Interfaces**

In the case of extending data models, to make them more robust it becomes essential to refer object classes to another model. A class or data type that is referenced from another model is shown as a rectangular block using dashed lines containing a rounded box using solid lines. In the rounded box, the name of the model in which the class exists is declared. An interface implies that there is a requirement in the current model to refer something from another model.

4.11 Theoretical context initiating model development

The study conducted and presented in this chapter relates to data modelling and its various types. It helped in initiating the process of developing a UK building regulation specific data model. As established beforehand, data modelling involves knowledge formalisation and the classification of data as suitable or unsuitable for automated checking. To classify building regulation data, a data filter system was developed; this data filter system along with other filters was explained in detail here. Knowledge formalisation begins with the selection of a sample of building regulation data. The building regulatory technical document Fire Regulation Part B1 and B2, published by the RIBAE, was selected as a sample and used for describing building regulation knowledge formalisation.

This chapter has explained what the different sampling methods are and which one was selected. The formalisation of building regulation data was followed by the development of an object based rule representation model by specifying objectified rule classes along with their attributes and assembling the relationships and hierarchy structure of these entities. These objectified rule classes were defined on the basis of clause context, clause requirement and objects extracted. Express-G, the modelling language, was used exclusively to develop the model; hence, it was elaborated upon in this chapter.

Chapter-5:

Knowledge Formalisation – a prerequisite for the object model development

5.1 Introduction

The literature review (Chapter 2, section 2.2) detailed existing international initiatives to address the issues relating to representation and execution of building regulations for automated compliance checking. It showed that there are several different software solutions used in these systems, such as BP-Expert, BCAider, DesignCheck, etc., and that these code compliance systems are largely prototypes in their developing stages. It was noted in particular that, due to the large variance in local standards (i.e. building regulations), not only in content but also in the degree of freedom encouraged in their interpretation (prescriptive versus performance), each solution developed needed to be customised in order to conform to the local standards and practices of the respective country (Khemlani, 2005; Niemeijer et al., 2009; Sing & Zhong, 2001). This is reinforced by (Eastman et al., 2009), who suggest that the first step towards automated code compliance is the interpretation of the structuring of building regulations. This chapter focuses on the development of a method for the interpretation of the England and Wales building regulations into a computer interpretable format for the facilitation of automated compliance checking. Two major concepts/activities are involved:

1. Knowledge formalisation of building regulations;
2. Development of an object data model schema (explained in detail in the next chapter).

As part of developing such a methodology, the England and Wales building regulations are studied and analysed in order to determine their suitability for automated compliance checking.

5.2 BIMs and IFC

Traditionally, designs have been represented in 2D format in drawings, with an emphasis on making them graphically and visually as correct as possible to enable professionals to understand and interpret them for necessary building information (Eastman et al., 2009; Hiekkila & Blewitt, 1992; Jeong & Lee, 2008; Nguyen, 2005). The object oriented nature of BIMs, coupled with BIM use by construction professionals, has increased in the UK to 35% in 2012 (Waterhouse & Hamil, 2011), meaning it is now potentially feasible to automatically check designs for compliance with the building regulations.

To create a BIM, a modeller uses semantically rich objects to build a virtual prototype. The resulting 3D integrated model is a far more rich representation of a building project than the traditional 2D drawings. The ability to attach ‘properties’ to objects means that the use of BIM is potentially a far more convincing instrument in communicating building designs in terms of obtaining sanction from the rule checking authorities (Davies & Raslan, 2010; Holzer, 2009; Sullivan, 2007). Recent developments in both software and hardware have resulted in a significant sophistication in representing building models. However, even today building

models do not typically include the detailed level of information required for fully automated rule checking.

The full benefits of BIM will materialize only through sharing of information across organisations, departments, information technology systems and databases (Bernstein & Pittman, 2004; Love et al., 2014). The IFC standard is the key to facilitating this interoperability in a cost-effective way and without relying on any particular product or vendor specific file formats (Conover, 2009; Solibri, 1999). IFC adds a common language for transferring information between different BIM applications, while maintaining the meaning of different pieces of information in the transfer (Ding et al., 2006; Eastman et al., 2009; Holzer, 2009).

The IAI's IFC standard is implemented in all the major BIM packages, which can consistently export valid IFC data files describing a building design, including the model hierarchy, properties and behaviours of building objects. The IFC is suitable in terms of standardisation, unambiguity, consistency and completeness of the description of building designs. The significance of IFC is further acknowledged on the basis of its use in existing code checking projects (Bazjanac, 2002; Han, 2005).

5.3 The England and Wales building regulations – suitability

It is a significant undertaking to understand and determine the nature of the England and Wales building regulations. The England and Wales building regulations consist of the 'requirements', within which each 'part' or 'approved document' sets out the broad objectives or functions of individual aspects of the building design and construction in a subjective manner. These are termed 'functional requirements' and are expressed in terms of individual clauses which set out what is reasonable, adequate or appropriate for achieving compliance. Most are informative or suggestive in nature, and can be incomplete in terms of expectation or contradictory in nature.

In the context of England and Wales, it is important to have building regulations that are responsive to the opportunities provided by recent technical developments. One way of potentially reaping the benefits is by developing methods for converting the England and Wales building regulation knowledge into computer interpretable rules (Hjelseth, 2009). However, there are characteristics of the England and Wales building regulations which make this transition difficult, as examined in section 5.3.1.

5.3.1 Subjective and complex in nature

It is important to acknowledge that the building regulations are complex and at times subjective in nature and therefore building regulation experts need to be involved in their conversion to computer interpretable rules to ensure the correct interpretations for code checking. Software

developers should not be expected to deal with the prediction of meaning from building regulations without a framework in place to allow domain experts to check on whether the understanding is correct or not. Such a framework would help to eliminate concern over loss of integrity of intent (Hjelseth, 2009). An example demonstrating the need for domain expert input is given below, extracted from Clause 1.11 of Part B1 of the England and Wales Building Regulations Approved Documents (Greenwood et al., 2010).

Example-1: **Clause 1.11** *Smoke alarms should normally be positioned in the circulation spaces between sleeping spaces and places where fires are most likely to start (e.g. kitchens and living rooms) to pick up smoke in the early stages of a fire (RIBA Enterprises, 2006).*

It is apparent that there is potential for varying interpretations in this instance, particularly with reference to "where fires are most likely to start". This could lead to errors during automated compliance checking, due to the complexities involved in extracting subjective parameters.

5.3.2 Inconsistent use of terminologies

An overview of the England and Wales building regulations by the author showed that entities or objectified concepts are often terminologically inconsistent, both within an approved document and across approved documents. Hence, knowledge formalisation becomes vital to ensure consistent terminology throughout all sections of the England and Wales building regulations, helping to make automation efficient and robust.

An example demonstrating the inconsistent use of terminologies is given below, using 'Section-1: fire detection and fire alarm system' of Part B1 of the England and Wales Building Regulations. Entities referred to in the section 1 clauses include alarm units, smoke alarms, detectors, smoke detectors, heat alarms, detection equipment, alarm receiving centres, heat detectors, wall mounted units and ceiling mounted units. All of the above are used inconsistently, sometimes within the same clause, and all refer to the same general concept, but it is unclear what differentiates them.

5.3.3 Complexity of their structuring and inter-relationships

The England and Wales building regulations are composed of 14 different parts which are updated frequently and individually for reasons such as changes in the law, consultation processes and extraordinary events (Bell et al., 2009; Greenwood et al., 2010). Since these 14 parts represent different specialised domains, they each get updated from the respective subject specialist. This has resulted in a situation where, from a code compliance point of view, continuity and consistency across the regulations is sometimes missing. Due to the need to be responsive to external events, the maintenance of an automated rule base needs to be kept separate from, and independent of, any proprietary software updates.

5.4 An object oriented approach

Building regulations are created and managed by people. They are represented in human linguistic formats, typically in the form of lengthy subjective text, numerical tables and sometimes equations (Bell et al., 2009; RIBAEnterprises, 2006). As more and more consultants are producing semantically rich object oriented building models, the need for a shift in authoring practice, bringing consistently defined building objects with associated properties to the forefront, becomes apparent (Jones, 2007). If the England and Wales building regulations are object centric, with consistently defined properties, it will be easier for architects to reflect that information into building models. In this context, RIBA have made progress by creating an elemental view of the building regulations (Bell et al., 2009). This elemental view helps in understanding the impact of clauses on individual building objects and is maintained via a complex matrix showing building objects and their relationship to building regulations clauses and the classification system UNICLASS. Knowledge formalisation, such as the above, provides suitable, significant and required data for the development of England and Wales building regulation specific object modelling.

After analysing the characteristics and suitability of the building regulations, a methodology has been formed to develop an England and Wales building regulations specific object data model. The following sections detail the development of such a method for the interpretation of the England and Wales building regulations into a computer interpretable format and data model development for the facilitation of automated compliance checking. It involves two major stages/activities as previously mentioned in section 5.1.

5.5 Knowledge formalisation

The basic aim of knowledge formalisation in the context of automated compliance checking is to interpret a body of building regulation knowledge and convert it into a set of rules that can be processed by a computer application (Hjelseth, 2009). The formalisation of England and Wales building regulations can be achieved in three steps:

- Selecting an appropriate building regulation sample belonging to a specific building related aspect;
- Classifying building regulation clauses into those which are computer interpretable declarative and those which are not informative;
- Decomposition of the declarative and informative clauses to extract semantics.

Formalisation of the building regulation/code knowledge is aimed at extracting the necessary logic out of the human language description format of the building regulations and formally interpreting them for the purpose of automated compliance checking.

5.5.1 Significance of knowledge formalisation

The importance of knowledge formalisation in the England and Wales building regulation compliance checking context has been well established in the above sections (5.1 – 5.4). The knowledge formalisation process forms a bridge between the existing England and Wales building regulations and an object data model for automated compliance checking. It provides suitable, significant and required data for the England and Wales building regulation specific object modelling. This shows one cannot start developing an England and Wales building regulation specific object model using building regulations in their current natural language based format, which is why knowledge formalisation is a prerequisite. The section above (section 5.5) explains what are the major milestones involved in the England and Wales building regulation specific knowledge formalisation. Upcoming sections explain the practical execution of those steps to achieve the same.

The significance of knowledge formalisation can be understood by referring to the work of (Ding et al., 2006), who illustrate knowledge formalisation for automated compliance checking of codes, standards, regulations and law. Some parts are suitable for easy implementation of automated compliance checking but some still have to be done by skilled professionals or domain experts, which in this case would be building regulation experts.

5.6 Execution of knowledge formalisation

As mentioned in section 5.5, building regulation knowledge formalisation commences with focussing on a particular aspect of building regulation, such as fire safety, and interpreting it in the context of a building design checking domain, such as design checking of a dwelling-house. The England and Wales Fire Regulation Part B1, comprising building regulatory technical documents for dwelling houses and published by RIBAE, is used as an example for describing building regulation knowledge formalisation in this study. After this, the application of a filter system is used to determine whether regulations/provisions are computer interpretable/processable or not (Eastman et al., 2009; Jeong & Lee, 2008). Only checkable provisions filtered from the system are taken into consideration here for automated compliance checking. Every entity featured in these measurable regulations is identified and extracted. This formalisation of measurable regulation data continues with extracting the facts and rules from the building codes (Yang & Xu, 2004).

5.6.1 Selection of a data sample

An understanding of the building regulations, their structure, makes up and the history of their growth from a statutory act to building regulations has been provided in the literature review chapter. The first step towards building regulation knowledge formalisation involves the

selection of an appropriate part from the official 14 approved documents of the building regulations. Fire Safety Regulation Part B1 was selected as a sample for this research. Part B1 was chosen as it has been updated recently, is well-documented and involves clauses that are used regularly in practice. It deals with dwelling houses, has 11 different sub-sections and comprises 137 clauses. Knowledge formalisation began with Section-1, which has 24 clauses. Figure 4.1 (*overview of part B*) shows the number of clauses (sample size B1) considered for the knowledge formalisation out of the total number of clauses. The England and Wales Fire Regulation Approved Document data sample comprises Volume B1 and Volume B2 (RIBAEnterprises, 2006). Figure 5.2 explains the scope of work by also showing how many clauses (sample size B1) were considered for the knowledge formalisation out of the total number of clauses. The last chapter (Chapter 4) described in detail the rationale and methodical approach used to choose such sample data.

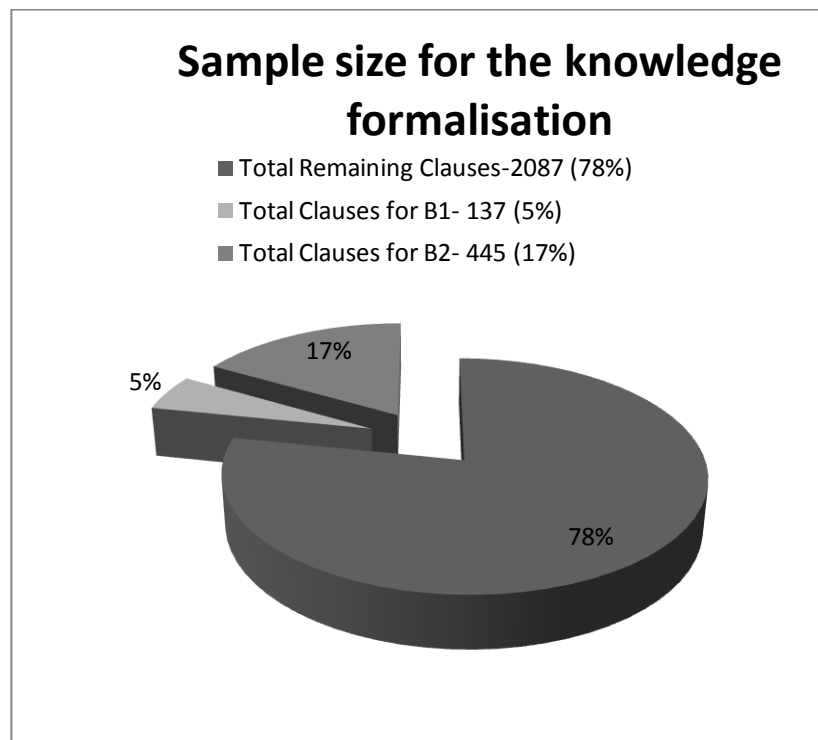

Figure 5.2: Total number of clauses (sample size) considered

5.6.2 Use of data filtering system

Once the data sample B1 was finalised, a filter system was used to determine whether the regulations were computer interpretable or not (Jeong & Lee, 2008). Only checkable or suitable provisions filtered from the system were taken into consideration for code compliance for the purpose of this research. Every entity featured in these checkable regulations was then identified and extracted.

Filters one and two were applied to the selected data sample to sort out clauses into 3 categories: declarative, informative, and clauses not suitable for automated compliance checking. Using the first filter, 27 declarative clauses were filtered out.

It is important to explain the concepts of the above mentioned clause categories in section 5.5, before explaining the knowledge formalisation stages.

5.6.2.1 Significance of declarative clause category

Declarative clauses are short in length, clear in their meaning and can be reinterpreted easily into a form that can be computer processable, thus suitable for automated compliance checking. Declarative clauses are measurable, readily checkable and involve geometry and factual data. These clauses contain entities with clearly defined attributes and constraints, i.e. they declare information unambiguously. Using the above definition as the first filter system, 27 declarative clauses were filtered out (refer to Figure 5.3 below).

Examples:

- A smoke alarm should not be fixed next to or directly above heaters or air conditioning outlets.
- There should be at least one smoke alarm on every storey of a dwelling house.

5.6.2.2 Significance of informative clause category

A typical approved document has plenty of clauses which are not obviously checkable in their nature. They tend to be more subjective and direct meaning cannot always be taken from them. They involve natural language and building regulation expertise is required to understand their exact meaning and to turn them into something checkable.

Clauses extracted using filter two were termed informative clauses as they possessed subjective information relating to building regulations. They did not deliver a very direct meaning and only contained data partially suitable for interpretation into computer processable rules. Fire Regulation Part B1 features 64 such informative clauses (refer to Figure 5.3 below).

Examples:

- There should be routes of sufficient number and capacity.
- There should be appropriate means of escape in case of fire from the building to a place of safety.

5.6.2.3 Clauses not suitable for automated compliance checking

By applying filters one and two, 27+64 clauses were extracted, as mentioned in section 5.6.2 above. The remaining 46 clauses (refer to Figure 5.3) from the fire safety Part B1 were such that

they were not suitable for automated compliance checking. Approved Document Part B1 is authored in such a way that it contains clauses which are not suitable for automated compliance checking due to their subjectivity and the fact that they require human judgement in order to make meaning out of them. On some occasions this type of data is purely for guidance, mainly for end users, and such clauses do not feature in the actual checking criteria. The current manual building regulation checking method does not consider this sort of information as a basis to supervise building drawings or building works. This will always be useful as additional information but currently it is outside the scope of the current compliance checking.

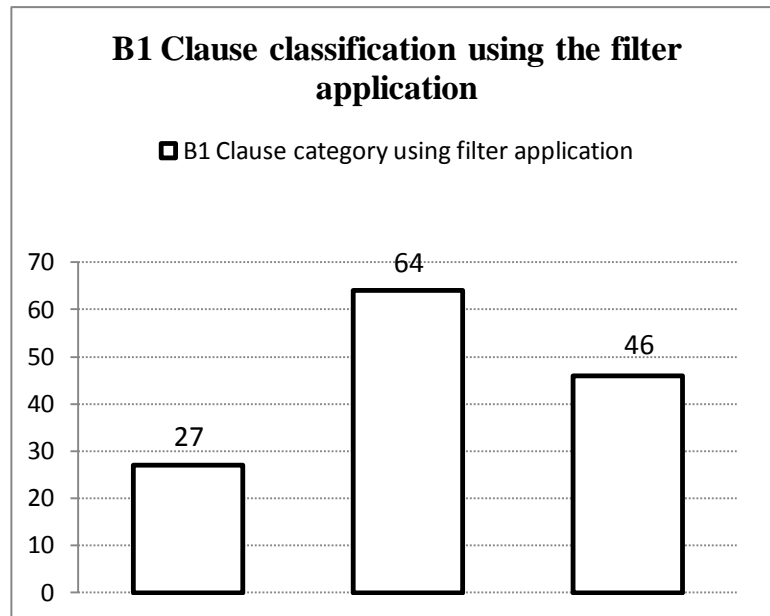

Figure 5.3: Sorting out clauses into different categories

Examples:

- Fires do not normally start in two different places in a building at the same time. Initially, a fire will create a hazard only in the part in which it starts and it is unlikely, at this stage, to involve a large area. The fire may subsequently spread to other parts of the building, usually along the circulation routes. The items that are the first to be ignited are often furnishings and other items not controlled by the Building Regulations. It is less likely that the fire will originate in the structure of the building itself and the risk of it originating accidentally in circulation areas is limited, provided that the combustible content of such areas is restricted.

The concepts and significance of the clause categories have been mentioned in section 5.6.2. A filter system was then applied to the Fire Safety Volume B1 as part of the knowledge formalisation procedure. The Part B1 clauses were classified into different categories, as shown in Figure 5.3 and Table 5.1.

Table 5.1: Forming clause categories as part of the knowledge formalisation for part B1

Clause Filter Level	Semantic Brief	Semantic Filter	Building Regulation Part	Clause Numbers
First semantic filter	Computer interpretable, information obvious as checkable/can influence project parameters, simple geometrical rules.		Fire Safety Part-B Volume-1	Clause 1.1, 1.3, 1.4, 1.5, 1.6, 1.8, 1.10, 1.11, 1.12, 1.13, 1.14, 1.15, 1.16, 1.17, 1.18, 1.20, 1.24, 2.8, 2.14, 5.3, 5.4, 5.7, 5.8, 5.14, 6.1.
Second semantic filter	Information is not obvious as checkable, needs interpretation to understand the exact content and meaning, codes/regulation involves natural language.		Fire Safety Part-B Volume-1	Clause 1.2, 1.7,1.9, 1.19, 1.21, 1.23, 2.1, 2.2, 2.3, 2.4, 2.5, 2.9, 2.10, 2.11, 2.12, 2.13, 2.16, 2.17, 2.18, 2.19,2.20,3.1, 3.2, 3.3, 3.4, 3.5, 3.6, 3.8, 3.9, 3.10, 3.12, 3.14, 4.5, 4.6, 4.7, 4.8, 5.1, 5.2, 5.5, 5.6, 5.9, 5.11, 5.13.
Remaining clauses not suitable for automated compliance checking	Clauses which do not figure under declarative or informative categories, clauses which are not suitable for automated compliance checking.		Fire Safety Part-B Volume-1	2.6, 2.7, 2.8, 2.15, 3.13, 4.4, 5.10, 5.12, 6.2, 6.3, 6.4, 6.8, 7.1, 7.5, 7.10, 7.13, 7.14, 8.2, 8.3, 8.4, 9.5, 9.6, 9.7, 9.8, 9.9, 9.11, 9.12, 9.14.

5.6.3 Elemental view of the building regulations

Once the declarative and informative clauses were finalised, the next task was to extract the physical entities along with their given or derived attributes using a manual data parsing technique. Figure 5.4 shows 122 entities extracted from Part B1 which have been used in the England and Wales Building Regulation specific object data model development.

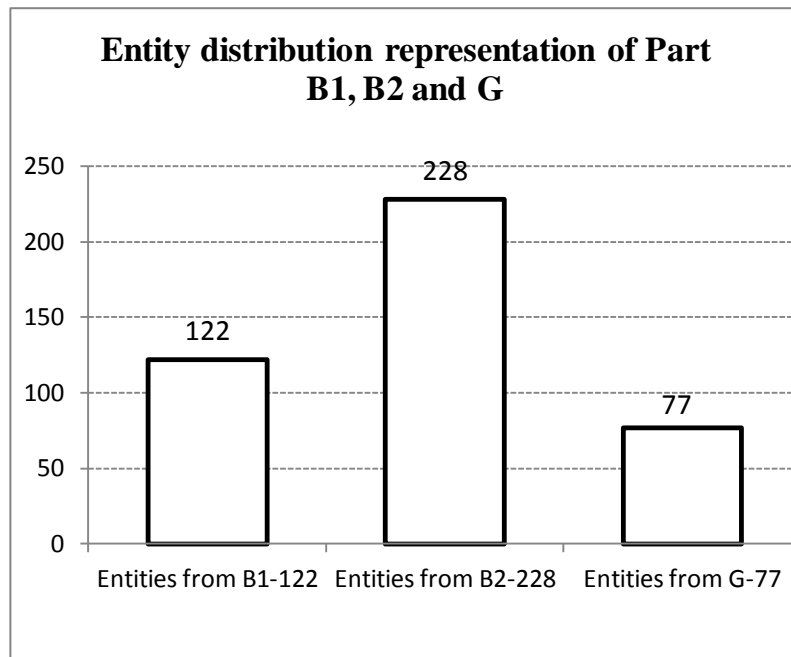

Figure 5.4: Representation of the number of entities extracted from Part B1, B2 and G

Fire detection system, boiler room, circulation space, ceiling and compartment wall are all examples of the entities extracted from the declarative as well as the informative clauses. The following is an entity distribution table (Table 5.4) suggesting whether physical entities feature in Volume B1, B2 or both.

Table 5.2: Entities spread over England and Wales Fire Safety Part B1 and Part B2

Approved Document	Fire Safety Volume -1	Fire Safety Volume -2
Total Clause Number	137	445
BReg Objects Extracted		
Automatic fire detection system	√	√
Air conditioning outlets		√
Automatic door release		√
Air circulation system	√	√
Assembly	√	√
Auditoria		√
Automatic door		√
Atria		√
Bathroom	√	√
Boiler room	√	√
Basement floor	√	√
Building envelope systems	√	√
Balcony	√	√
Circulation space	√	√
Central monitoring point	√	√
Conductor	√	√
Compartment wall	√	√
Corridor		√
Ceiling	√	√
Car park		

The above extracted entities formed the basis for the development of an IFC compliant England and Wales building regulation specific data model.

5.6.3.1 Extracting semantics

Once the declarative and informative clauses were filtered, the physical entities along with their given or derived attributes were extracted. In total, 137 clauses were targeted as a sample and 122 entities were extracted (refer to Figure 5.4) to inform an elemental view of the England and Wales fire safety clauses as part of the knowledge formalisation process. The above methodology was repeated for the fire safety Part B2. From the 445 clauses in Part B2, 228 entities were extracted.

To further explain in detail, Section-1 covering fire detection and fire alarm systems can be used as an example from the fire safety Part B1 document. Clauses are decomposed to sort them out into declarative and informative clauses and form pseudo codes. It is beyond the scope of this research to consider all 91 declarative and informative clauses and show their sequential decomposition and pseudo code formation and hence Section-1 is selected. Tables 5.3 and 5.4 below show how declarative or informative clauses sorted using a filter system can be decomposed using major steps such as identifying objects, extracting checkable clause content and forming pseudo codes, which provides a foundation on which an England and Wales building regulation specific data model can be built.

Table 5.3 explains how from Section-1, out of a total of 24 clauses, the declarative clauses were considered along with their chronological decomposition.

- Example B1: 1.2- The installation of smoke alarms, or automatic fire detection and alarm systems can significantly increase the level of safety by automatically giving an early warning of fire. The following guidance is appropriate for most dwellinghouses. However, where it is known that the occupants of a proposed dwellinghouse are at a special risk from fire, it may be more appropriate to provide a higher standard of protection, e.g. additional detectors.

Table 5.3 below explains how B1: 1.2 was broken down step by step by extracting objects, finding out checkable content and forming pseudo codes. Such pseudo codes helped in determining the check-ability of clause B1: 1.2.

- Example B1: 1.5- A dwellinghouse is regarded as large if it has more than one storey and any of those storeys exceed 200m².

Table number 5.3 below explains how the B1: 1.5 declarative clause was considered and broken down. It involved identifying objects, extracting checkable data and formation of pseudo codes.

Table 5.3: Examples of declarative clauses and their breakdown

Clause No.	Objects Identified	Checkable Content	Rules Extracted
B1:1.2	Smoke alarms, automatic fire detection, alarm system, storey, early warning, dwellinghouse, occupant, special risk, fire, additional detectors.	Check whether additional detectors are provided or not. Check if the occupants of a dwelling house are at a special risk. Check if the occupants need a higher standard of fire protection.	If dwellinghouse has occupants ≥ 1 and (occupant) person is at special risk from fire = true, then detectors must be >1 , then passed, or else failed.
B1:1.5	Dwelling house, storey, storey area.	Check if a dwelling house comes under a large dwelling house category. Check if the dwelling house is more than one storey. Calculate the area of each storey of a large dwelling house. Check whether the area of a single storey exceeds beyond 200m ² .	If dwellinghouse is of area type large dwellinghouse = true and large dwelling house storey area $> 200\text{m}^2$, then passed, or else failed.
B1:1.1 2	Fire detection and fire alarm systems, smoke alarm, storey.	Check whether each storey of a dwelling house has one smoke alarm.	If smoke alarm number on every storey ≥ 1 , then passed, or else failed

Examples of informative clauses and their modelling

Table 5.4 below explains how B1: 1.1 and 1.4 were broken down by extracting objects, finding out checkable content and forming pseudo codes.

- Example B1: 1.1- Provisions are made in this section for suitable arrangements to be made in dwellinghouses to give early warning in the event of fire.
- Example B1: 1.4- The smoke and heat alarms should be mains-operated and conform to BS 5446-1:2000 or BS 5446-2:2003, respectively: Fire detection and fire alarm devices for dwellinghouses, Part 1 Specification for smoke alarms, or Part 2 Specification for heat alarms. They should have a standby power supply, such as a battery (either rechargeable or non-rechargeable) or capacitor. More information on power supplies is given in clause 15 of BS 5839-6:2004.

Table 5.4: Examples of informative clauses and their breakdown

Clause No.	Objects Identified	Checkable Content	Rules Extracted
B1:1.1	Dwellinghouse, early warning.	Check whether suitable arrangements have been made in a dwelling house for the event of fire.	If a dwellinghouse = true then fire detection and alarm system must be ≥ 1 , then passed, or else failed.
B1:1.4	Smoke alarm, heat alarm, mains operated, fire detection and fire alarm devices, smoke alarm, heat alarm, standby power supply, battery, capacitor.	Check whether smoke alarms and heat alarms are mains operated. Check whether smoke alarms and heat alarms conform to BS 5446-1:2000 or BS 5446-2:2003. Check if smoke alarms and heat alarm devices have a standby power supply, if they have a rechargeable or non-chargeable battery, and if they have a capacitor.	If fire detection and alarm system is mains operated = true and fire detection and alarm system is standby power supply type = true and has battery or capacitor ≥ 1 , then passed, or else failed.
B1:1.6	Fire detection and fire alarm systems, smoke alarm, storey.	Check if a two storied large dwellinghouse is fitted with a fire detection system and a fire alarm system. Check if the fire detection system and the fire alarm system are of grade B category LD3 standard.	If dwellinghouse is of area type largedwellinghouse = true and storey element number = 2 fire detection and alarm system must be ≥ 1 , then passed, or else failed.

5.6.3.2 Information provided as guidance

It was noticed that in Part B1 a large amount of the information provided was for guidance and dealing with such information was challenging. The information comprised supportive guidance related to requirements and general guidance for stakeholders, clients and sometimes building authorities as well. It was further noticed that this information was haphazardly provided and not grouped together on the basis of the physical entities it was related to. Modelling of such natural language based information is an enormous challenge.

It was not necessary that all information provided in Part B1 should be turned into checkable computable rules or should be part of automated code checking, as 50% of such information was merely guidance. BIMs cannot represent this sort of information as it is too subjective and descriptive. The current manual building regulation checking method does not consider such information as a basis to supervise building drawings or building works. It will always be useful as additional information but not mandatory in the automated code compliance context.

5.7 Initiating object data model development

As explained above, knowledge formalisation has provided a foundation by making formalised knowledge of the England and Wales fire safety building regulations available, initiating building regulation specific data model development work. Using the body of work or the output, the IFC compliant England and Wales building regulation specific data model has been developed.

The entities, once extracted, were used as the basis for creating an object based representation of Part B of the building regulations. Initially, this ‘data model’ was created by specifying object classes for each entity and defining each attribute associated with that entity. Attributes were extracted using the same method as above, i.e. on a clause by clause basis, and so each object class was developed to give a semantically rich object based view of the building regulations. The data model was further enhanced by establishing relationships between the object classes, including establishing a hierarchical structure. The hierarchical structure was particularly useful for rationalising some of the terminology ambiguities; for example, the relationship between smoke alarms, smoke detectors, heat alarms, and detection equipment. The use of enumerations for many of the attributes, extracted from the building regulations, was also very significant for formalising the England and Wales fire safety building regulations context, allowing the model to represent allowable values for non-habitable spaces.

In the same way Part-1 knowledge formalisation has been explained in sequential stages, Part-2 building regulation data model development is explained in the next chapter 06.

5.8 Conclusion

This chapter has examined the problems associated with the England and Wales building regulations with respect to their suitability for computer interpretable rules for code compliance checking. To overcome these problems and to convert the England and Wales building regulation knowledge into a computer interpretable rules format, a method in the form of knowledge formalisation was developed in this research. Many of the transition related problems described above can be overcome through the knowledge formalisation process.

While BIM is becoming popular, it is not common for building models to contain semantically rich information. An object based representation of England and Wales building regulations could help to define the minimum amount of data required in order to be able to test for compliance, and in doing so help to add value to semantically rich models. This object based representation starts with knowledge formalisation and hence it has been concluded that knowledge formalisation is essential before one can start the development of a building regulation specific object model.

Using knowledge formalisation, over 350 semantic entities were identified from parts B1 and B2 of the England and Wales Building Regulations. It was observed that many of these entities, for example the space model, had relevance to other parts of the regulations. However, it has been concluded that creating formalisations of regulatory information will generate many more detailed England and Wales specific entity definitions than are currently in the IFC schema. A significant number of these definitions are, in reality, refinements of IFC definitions. For example: 1) “Habitable Space” is a refinement of “IfcSpace”; 2) “Circulation Space” is a refinement of “IfcSpace”. Currently, it may not be feasible to write computer interpretable rules for complete 100% automated compliance checking; nevertheless, a significant number of building regulations are suitable for automated compliance checking. The process of knowledge formalisation helps in estimating the number of declarative clauses. A specific focus on automating the process for the declarative clauses in Part B1 could have significant benefits for the industry, including:

- a shortened building regulation application process;
- an ability for consultants to pre-check applications for completeness of information, as well as compliance, at any stage in a project; and
- a consistency check for building regulation authors.

Chapter-6:

Development of Object Based Building Regulation Model

6.1 Introduction

In Chapter 5, knowledge formalisation was discussed and this provided a foundation for developing a object model by making formalised knowledge of the fire safety building regulations (England and Wales) available. Using this body of work, an IFC compliant building regulation specific object model was developed. The knowledge formalisation began by focusing on the first 24 clauses of section-1 (i.e. fire detection and fire alarm systems). Hence, the building regulation specific object model development also started with the same section using the output from the knowledge formalisation stage. The output of the knowledge formalisation was identification of 122 disparate objects and their associated attributes. Turning these objects into object classes and using an entity-relationship method to establish relationships between such classes was a starting point. This formalised knowledge was turned into a object model using the following broader stages (Auel, 2005).

- Object identification
- Object transformation into classes
- Defining attributes and enumeration values
- Establishing semantic relationships

An information system can be described as one which supplies information needed by an organisation. An information system receives information, stores it, processes it and provides access to it at the request of users. When the information is to be stored and processed, it needs to be coded into some descriptive form. Such coded information is called 'data'. A collection of data stored on a physical media is termed a 'database' (Gray et al., 1992). A database is primarily concerned with structured or formatted data, i.e. many instances of data possess sufficient similarity to classify them into a class or category. This makes it possible to separate the description of the data from the actual data. A data model is the primary tool for designing a database. A conceptual schema which is part of an information system is a single, integrated definition of the data; it provides a consistent definition of the meanings and interrelationships of the data in order to share, integrate and manage the data (T. Lee, 2000).

The England and Wales fire safety object model was developed by specifying object classes and summarising their attributes, as well as establishing relationships and a hierarchy structure for these object classes. The IFC data model was referred to during the development and structuring of the fire safety object model (Yang & Xiang, 2001). The EXPRESS-G language was extensively used to create this particular data model. A data modelling technique was employed to form the building regulation specific object model and this is explained in detail in this chapter (Auel, 2005). Details about data model types, their evolution and their development are given in Chapter 4.

6.2 Necessity for an object model

The need for a building regulation specific object data model is explained and relevant issues are highlighted.

6.2.1 Building information models lack data

At present, although the AEC industry has moved from using data in a 2D CAD format to BIM data (Waterhouse & Hamil, 2011), there is a need to focus on the process of building model authoring by the design team. Currently there is no single software application which can claim to have the capability to fully populate data in a building model. This situation is further aggravated by the fact that there is an issue of model ownership and liability in model authoring. At present the focus of building model authors is largely on the visualisation rather than the building information and they are partly helpless to make models more semantically rich due to software applications' incapability to allow the same (Dix, 2009; Hamil, 2011).

In the context of automated compliance checking, model authors are not focussing on adding the required England and Wales building regulation specific information as it is not the established practice yet. If they want to, software applications must be developed that help them to do so. Model authors also need help with producing formalised data from the building regulations that are readily available so that they can include them in their building models. Another challenge is how to represent complex building regulation related information (in building models), which is often checked on the basis of flawed human judgement for code compliance. It is difficult to interpret complex information into geometrical parameters.

As a result of the above, current building models are not semantically detailed enough for use in the automated building regulation compliance checking process. Thus, to extend this information into building models or to make more building information available for compliance checking process, an IFC-compliant England and Wales building regulation specific object model needs to be developed. This study has focussed on the fire safety building regulation (Yang & Xiang, 2001; Yang & Xu, 2004). The overall implication of this existing situation is that there is a realisation/awareness that international CAD tools should be employed to author the majority of building models in the form of elements, materials, geometry, etc., and an extension programme is a must for author data which is missing.

6.2.2 Building models exported to IFC

Present software applications like Autodesk Revit, Graphisoft , ArchiCAD, Gehry Technologies- digital project designer, Vectorworks Architect, etc., can help to create building models. IAI's IFC has been implemented in several such AEC CAD packages and can consistently export valid IFC data files describing building model information (Yang & Xu,

2004). However, when such models get exported into an IFC file, it cannot represent all the data. This results in data loss, part of which at times is required from a building regulation compliance checking point of view. Software vendors are partly responsible for this particular problem because they are not fully IFC compliant. They need to find a solution whereby building models, when they get exported as an interoperability standard, should be able to represent all the information in the IFC files. This is why building regulation related information needs to be modelled with reference to the IFC standards (Jones, 2007; Yang, 2003).

6.2.3 IFC international standard data

- As discussed in the literature review chapter, section 3.4, the IFC standards are being used as interoperability standards to represent 3D building design information. Also as IFC standards act as international open standards for interoperability, they focus on universal standards. They do not represent entities or attributes which are important in the local context of UK automated compliance checking and that is why IFC standards are not the entire solution for interoperability standards for automated compliance checking.
- The existing IFC schema has defined many universal AEC objects for use of AEC applications in architectural design, cost estimation, building service design, construction, and facility management (Yang & Xiang, 2001). This indicates that the IFC data model is rich in its semantic content but in terms of the information modelled by IFC, it is not necessarily fully suitable for use in automated building code compliance checking. This is why the development of a UK building regulation specific data model is imperative (Yang & Xu, 2004). Again, although the IFC data model is very rich in its semantic content, such semantic information is scattered into different domain spaces of the IFC model. As IFC standards are designed as a set of international standards, navigating through such a large model is difficult.
- The IFC data model has a complex hierarchical structure and relations established between objects are not suitable for UK compliance checking needs. During the compliance checking process, checking of an IFC schema requires many rules and is rather tedious.

In answer to the issues highlighted above, the England and Wales building regulation specific object model was developed for the specific context of the fire safety building regulations for dwelling houses. It supplements building design objects and attributes that are significant in the building regulations compliance checking context, into the existing IFC model to facilitate automated compliance checking. By integrating the IFC schema with the developed object model, a schema has been provided which is in accordance with the

needs of England and Wales building regulation compliance checking and which is easy to navigate, presenting relationships in the building regulation context.

6.3 Fundamental principles used in the development

Considering the issues mentioned in section 6.2, the UK building regulation specific object data model was developed as a conceptual information model mainly for automated compliance checking. The building regulation model consists of computer interpretable definitions for architectural design entities, semantic relationships and entity attributes (Yang & Xiang, 2001). The following principles/methods have been considered for this development (Batini, Ceri, Kant, & Navathe, 1991).

6.3.1 Object identification

An entity can be loosely defined as a thing that exists and corresponds to real world objects, such as building elements like wall, door, window etc., but it can also be of an abstract nature.

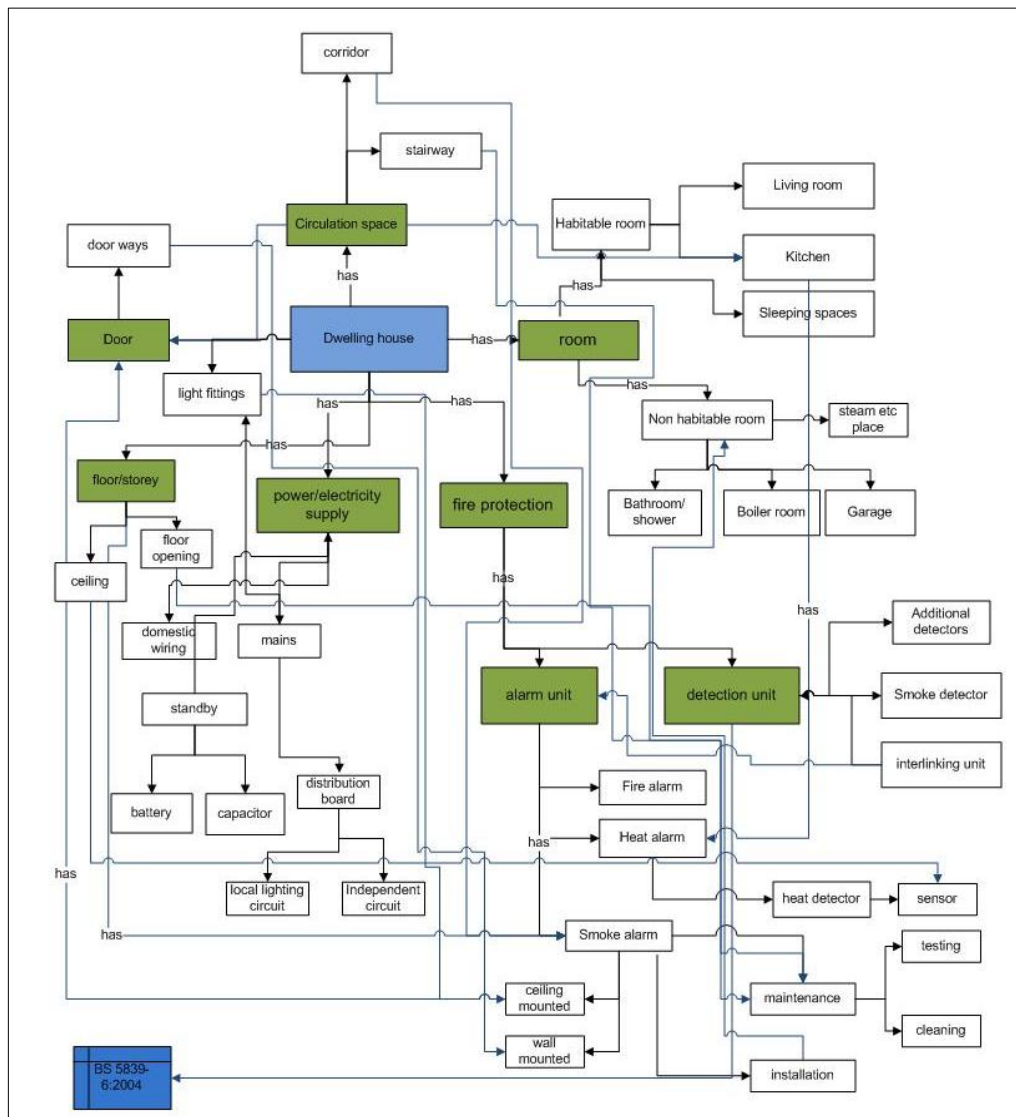

Figure 6.1: Entities identified from the fire safety clauses

An entity is a conceptual object, usually a noun in the requirement specification (Gray et al., 1992). To name few of the basic entities, they include floor, space, room, detector, alarm, door, window, etc. (see Figure 6.1).

6.3.2 Object transformation into classes

To construct an object into a class requires further information, such as information on its attributes, in order to describe it fully. In this context, a building regulation related object can be turned into an object class when relevant clauses provide considerable information about it in the form of attributes. Also, if the same object is described using various terminologies in different sections of the building regulations, such objects can be modelled into a single class to represent them consistently, with various relevant attributes attached.

As explained in Chapter 5, during the knowledge formalisation where 137 clauses from B1 were considered, 122 numbers of different entities were identified and extracted but not necessarily all of them were turned into object classes. Putting an object into an object class was completely based on the context of the building regulation clauses in which they appear and their significance in the same.

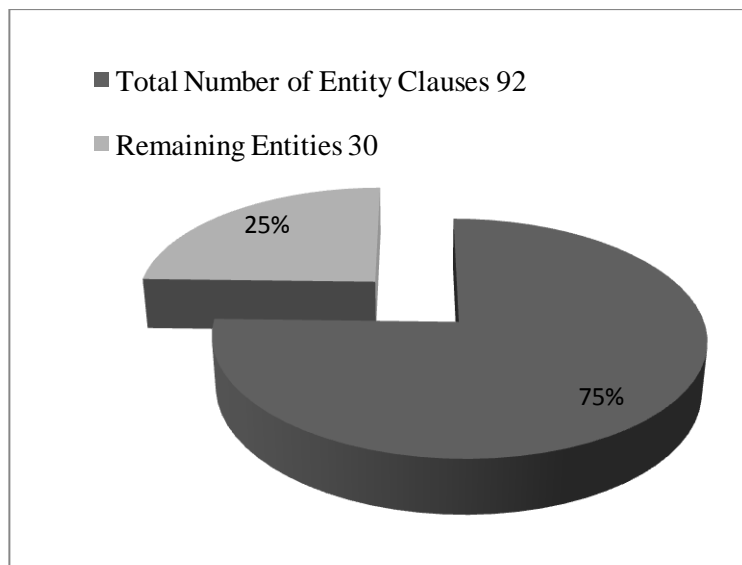

Figure 6.2: Entities into entity classes

As shown above in Figure 6.2, the UK fire safety data model development started with section-1, fire detection and fire alarm systems, with a focus on the objects identified during the knowledge formalisation of the same section. The objects identified were alarm unit, detection unit, fire alarm, smoke alarm, heat alarm, heat detector, interlinking detector, sensor, fire protection, power supply, etc. Noticeably, all of them (real or abstract objects) are not formally represented in the Express-G data development application as object classes. Those objects that possess important information in the form of attributes and that showed relationships with other

objects were represented as object classes. Figure 8.3 shows the entity class called FireDetectionAlarmSystem, which is not mentioned in section 1 of the building regulations but was created to establish a hierarchical relationship between the entities, such as detector and fire alarm.

- Example - Entity FIREDETECTIONALARMSYSTEM has an object to object relationship with entity SPRINKLERSYSTEM and entity DETECTIONEQUIPMENT, and this is represented as object to object and not in the form of simple data types. The reason behind this is that entities like sprinkler system and detection equipment can be expanded further according to the context of building regulations.

6.3.3 Defining attributes of simple types and enumeration type

Everything which comes under the description of a class or everything that is related to a class is considered to be an attribute or data member (Batini et al., 1991; Gao, Yue, & Gao, 2008). Classes were extended by representing the relevant attributes to each of the individual classes on the basis of information extracted from the fire safety clauses.

After establishing the primary object classes, such as FIREDETECTIONALARMSYSTEM, FIRE ALARM, DETECTOR, DETECTION EQUIPMENT, the fire safety object model was extended by associating attributes to the object classes. There are different simple data types in EXPRESS-G and they were used to show relevant attributes.

To avoid duplication of information in the form of attributes, if two classes showed the same attribute data type, such attributes were moved up the class hierarchy structure, with a supertype class being attached to them.

- Example -
 - 1 In reference to clause numbers 1.11, 1.12, and 1.13, to identify more effectively the location of the entity FIREALARM, it was represented with a simple data type attribute Boolean and was used in instances such as whether the fire alarm is in the kitchen or not, or the fire alarm is located in the circulation space or not.
 - 2 In reference to clause number 1.15, to identify or find out the Entity Detector's distance from the adjacent light fitting, it was represented with an attribute positive length measure.

- ***Enumeration Data Type***

In the UK fire safety building regulations, at times an object may have more than one possible attribute type value. Such possible attribute types or values are spread across different clauses

and in different contexts, so to extend the fire safety data model, such values were put together under an enumeration data type and attached to the relevant object classes.

- Example-

DetectorType enumerations BRegDetectorType = ENUMERATION OF

(HEATDETECTOR,
SMOKEHEATCOMBINEDDETECTOR,
OPTICALSMOKEDETECTOR,
IONISATIONCHAMBERSMOKEDETECTOR);
END_TYPE;

- Example-In reference to clause number 1.15(b), to identify a detector's mounting type, represented as SMOKE ALARM/DETECTOR has mounting enumeration data type attributes and represented as BRegSmokeAlarm/DetectorType = ENUMERATION OF

(WALLMOUNTINGTYPE,
CEILINGMOUNTINGTYPE);
END_TYPE,

- In reference to clause number 1.4, to establish the type of power supply for the detection and alarm system, power supply types are mentioned in different clauses of the building regulations, but by using the enumeration type, all power supply types were put together in one place and the most suitable attribute can be chosen from these possible values. Power Supply enumeration type is represented as
TYPE PowerSupplyTypeEnum = EXTENSIBLE ENUMERATION OF
(MAINSPOWERSUPPLY,
STANDBYPOWERSUPPLY,
MAINSONLYWITHBATTERY,
STANDBYPOWERSUPPLYWITHBATTERY,
STANDBYPOWERSUPPLYWITHCAPACITOR,
MAINSPOWERSUPPLYWITHCAPACITOR,
MAINSPOWERSUPPLYWITHINDEPENDANTCIRCUIT),

END_TYPE;

6.3.4 Establishing semantic relationships

After the fire safety specific object classes were established by attaching relevant attributes to them, the object model was extended by establishing semantic-relationships between object classes. A relationship captures how entities are related to one another. Relationships can be thought of as verbs, linking two or more nouns. Which object is related to which can be explained easily, but it is significant to explain the rationale on which the relationship is established. The current object data model allows two types of relationships: an object to object

type relationship and a supertype-subtype relationship. The relationships among entities are represented in the data model using the following rationales:

- In response to how the UK building regulation clauses portray objects.
- In accordance with the requirement or need from a compliance checking point of view.
- Such that the schema queries should be easily solved.
- *Object to object relationship type*

By using the above mentioned rationales in section 6.3, the object to object relationship type was used throughout the data model development (see Figure 6.3). It can be demonstrated using the following examples.

- Example–
- The entity FIREDETECTIONALARMSYSTEM has an object to object relationship with objects including DETECTOR, FIREALARM, SPRINKLERSYSTEM, and DETECTIONEQUIPMENT. The entity FIREDETECTIONALARMSYSTEM is represented by establishing an object to object relationship type with other entities, including SPRINKLERSYSTEM and DETECTIONEQUIPMENT; this is represented by object to object and not in the form of simple data types. The reason behind this is that entities such as sprinkler system and detection equipment can be expanded further by turning them into classes, as per the fire safety building regulations context.
- The circulation space related entity FIREFIGHTINGSHAFT is represented by showing it having an object to object relationship with other circulation space related entities. It is represented by showing a relationship with objects such as FIREMAINS, SHAFTDOOR, VENTILATIONOPENINGS, etc., and this relationship is established on the basis of the clause context.
- Fire fighting lift technically comprises liftcar, lift well and lift control system. In the data model development context, the circulation space related entity fire fighting lift is shown to have an object to object relationship type with entities including liftcar, liftwell and lift control system; the relationship type cannot be supertype-subtype in nature.

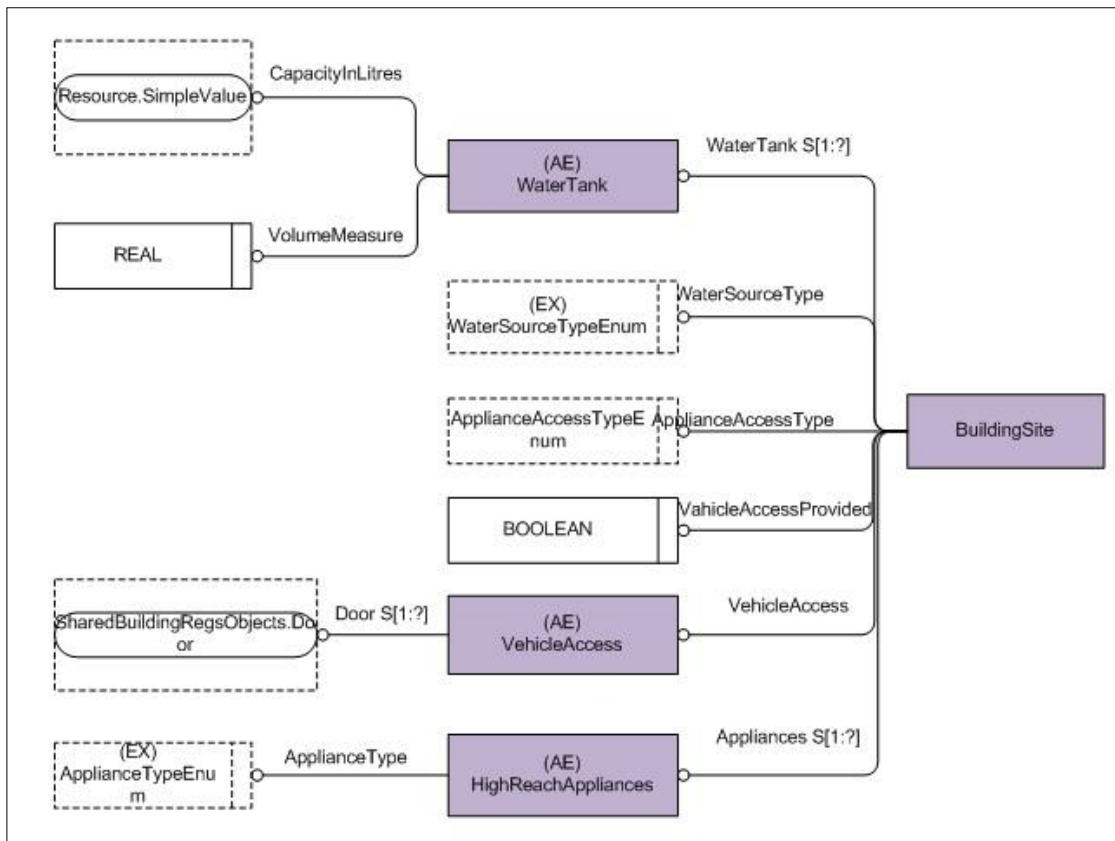

Figure 6.3: BuildingSite modelled as an entity class

- ***Supertype-subtype relationship***

Throughout the data model development, the supertype-subtype relationship was used consistently. It can be demonstrated using the following examples.

- Example–The entity COMBINEDALARMDETECTOR is a subtype and the entity FIREALARM acts as a supertype. COMBINEDALARMDETECTOR inherits all the properties of a fire alarm but also possesses the properties of a detector.
- Internal stairway inherits all the properties of a stairway and that is why it is represented as a subtype. Also, internal stairway possesses more attributes than entity stairway.
- The entity space has a supertype-subtype relationship with habitable space, non-habitable space and circulation space.
- The entity circulation space has a supertype-subtype relationship with entities including corridor, stairway, etc.

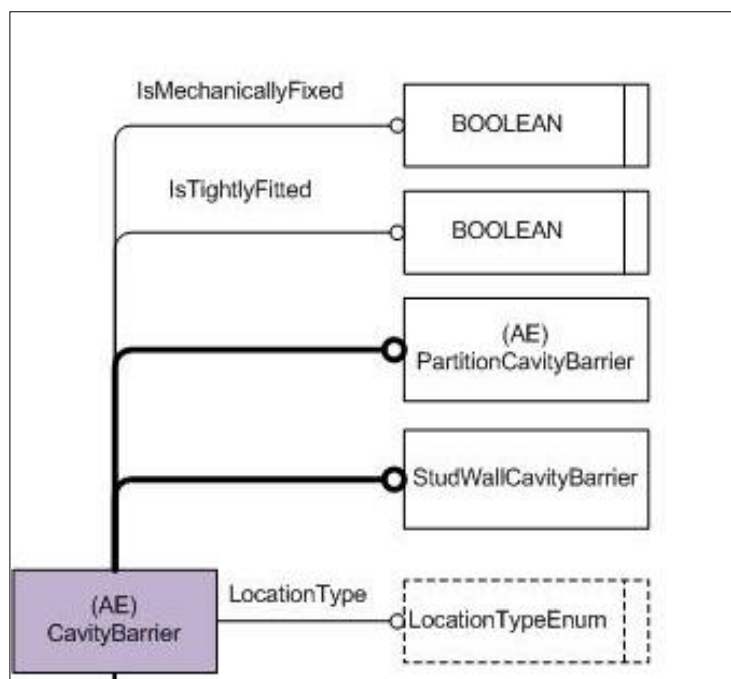

Figure 6.4: Entity class cavity barrier shows supertype-subtype relationship

- The entity cavity barrier has a supertype-subtype relationship with partition cavity barrier and stud-wall cavity barrier (see Figure 6.4).
- Smoke vent has a supertype-subtype relationship with mechanical smoke vent and natural smoke vent, as they inherit all the properties of a smoke vent.

6.4 Building regulation model – summarised process

An object oriented representation of Part B of the building regulations is explained by elaborating major stages sequentially in detail. However for easier and clear understanding of the developed methodology, a summarised view is presented using an example.

For the object model development the entities were extracted from the part B1 fire safety clauses, on a clause by clause basis. The entities, once extracted were used as the basis for creating an object oriented representation of Part B of the building regulations. This “object data model” was created by specifying object classes for each entity and defining each attribute associated with that entity. Attributes were extracted using the same method as above, i.e. on a clause by clause basis, and so each object class developed to give a semantically rich object based view of the Building Regulations.

In order to demonstrate this methodology clause number 1.15 from B1 is considered for modelling as it is of the declarative type. Clause 1.15 relates to the positioning of smoke alarms/detectors and is shown below in figure 6.5.

Clause 1.15 Smoke alarms/detectors should be sited so that:

- a) There is a smoke alarm in the circulation space within 7.5m of the door of every habitable room
- b) They are ceiling mounted and at least 300mm from walls and light fittings. Units designed for wall mounting may also be used provided that the units are above the levels of doorways opening into the space and they are fixed in accordance with manufacturer's instructions
- c) The sensor in ceiling-mounted devices is between 25mm and 600mm below the ceiling (25-150mm in the case of heat detectors or heat alarms).

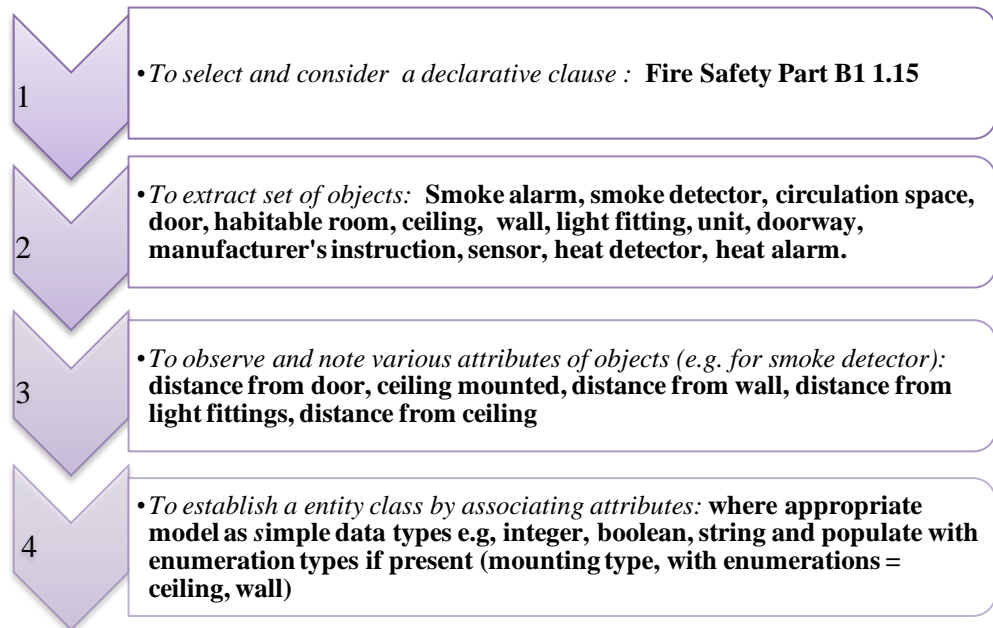

Figure 6.5: Development of an object class from Fire Safety Part B1 1.15

Figure 6.5 details the entities extracted from clause B1-1.15, including smoke alarm, circulation space, door, habitable room, wall, light fittings, doorway etc. Once the entities are extracted, the attribute types are observed and noted from the clause. These attributes are then associated with their respective extracted entities and the model is further enhanced by establishing relationships between the object and entities including establishing hierarchical structure. The hierarchical structure was particularly useful for rationalising some of the terminology ambiguities, for example the relationship between smokes alarms, smoke detectors, heat alarms, and detection equipment. Figure 6.6 illustrates the smoke detector object class

```
ENTITY Detector;
DistanceBelowCeiling: (OPTIONAL)
PositiveLengthMeasure;
DistanceFromLightFitting:
PositiveLengthMeasure;
DetectorType = ENUMERATION OF
(WALLMOUNTINGTYPE,
CEILINGMOUNTINGTYPE);
END_TYPE;
```

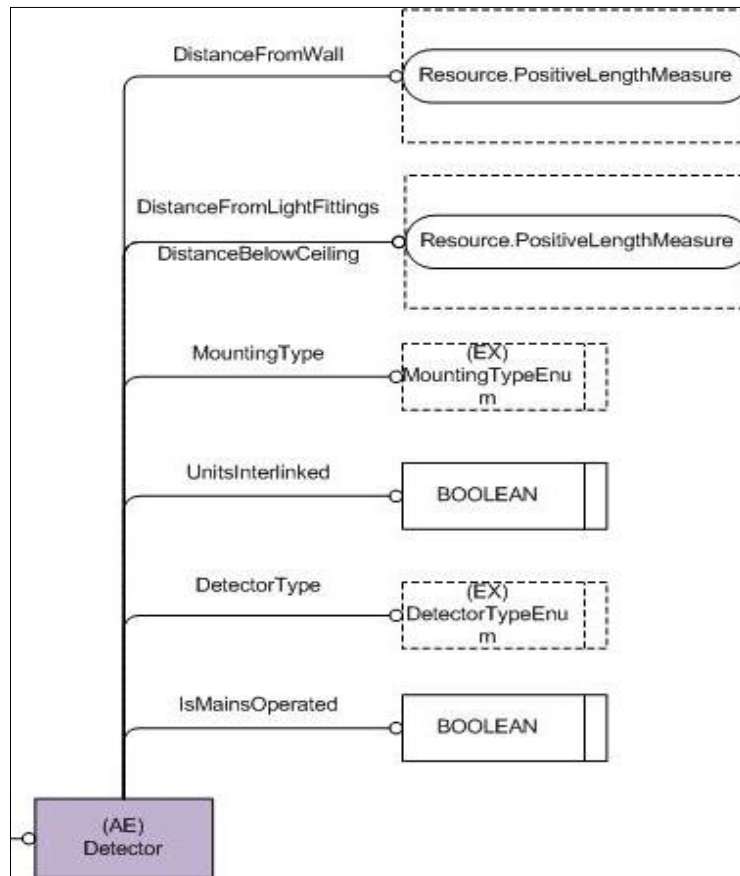

Figure 6.6: Object class Detector represented in Express-G.

The use of enumerations for many of the attributes, extracted from the building regulations, was also very significant, allowing the model to represent allowable values for non-habitable spaces, for example, or as shown above, the different mounting types for a detector.

6.5 Modelling of key abstract concepts

The UK fire safety building regulations possess a significant number of abstract as well as complex concepts, such as escape route, concealed spaces, opening protection and roof coverings, which are not readily suitable for modelling. These abstract concepts are specific to UK building regulations; each concept consists of many layers of information and many subplots. Modelling of such information in the form of entity classes is a testing task. How these abstract concepts were modelled is explained in the form of examples.

Example-1: HabitableRoom

Fire safety clause numbers 1.3, 1.5, 1.6, and 1.7 involve abstract concepts, such as room, habitable, and non-habitable room type.

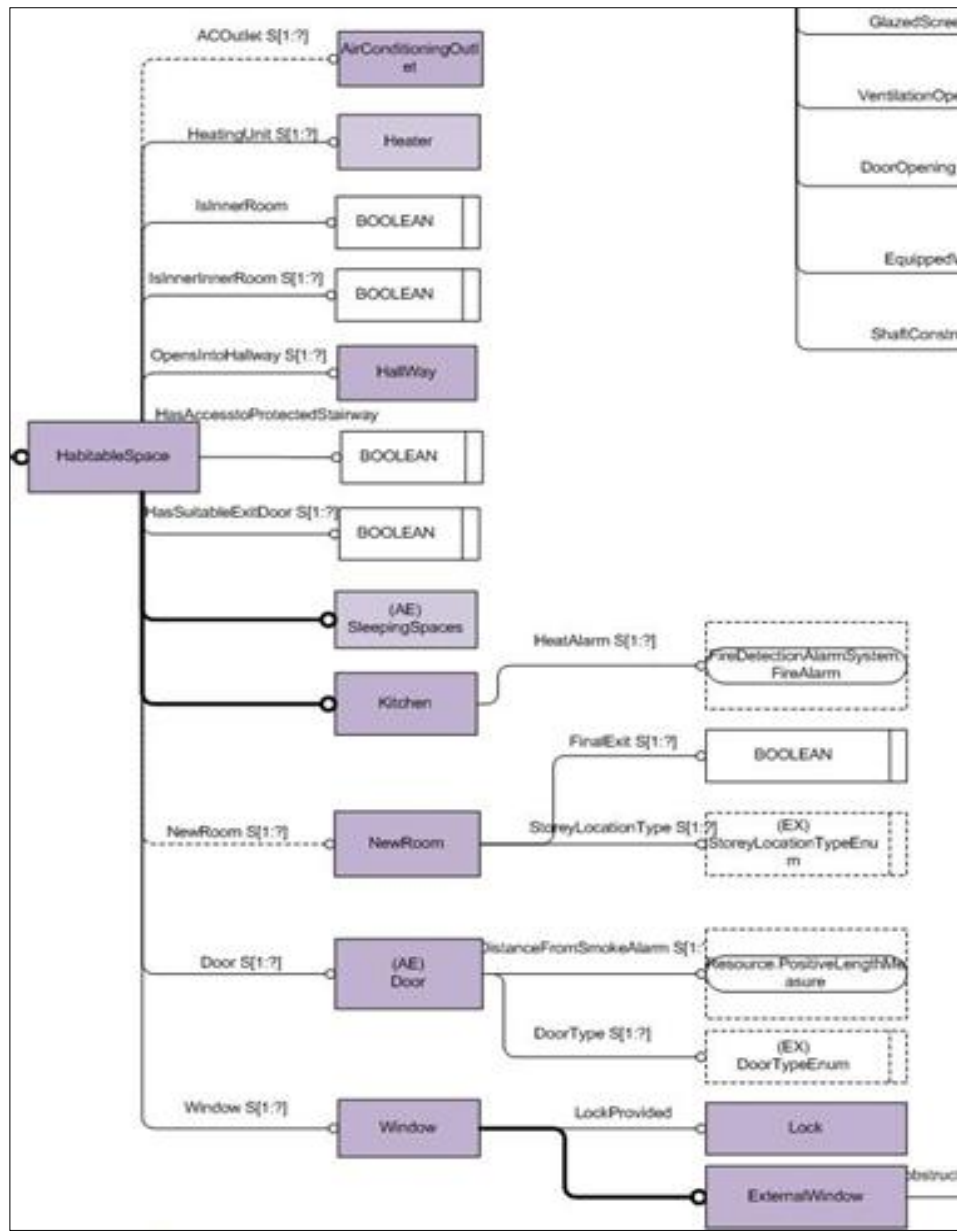

Figure 6.7: Habitable space modelled as an entity class

Due to their abstract nature, it was important to understand their inclusive meaning and how they are defined by the building regulation authority. After understanding them fully and understanding the context in which they are used, they were successfully modelled.

As shown in Figure 6.7 above, habitable space and non-habitable space are modelled as entities having attributes attached to them; they are both subtypes of entity space. The habitable space entity is a supertype and has entities such as sleeping spaces, kitchen and hallway as subtypes.

- Entity class's habitable space and non-habitable space are subtypes of the generic space entity class.
- Entity space is defined more comprehensively here compared to the IFC.

Example-2: EscapeRoute

Means of escape is an abstract concept from a modelling point of view; the fire safety regulations have an important but lengthy section about it. The means of escape section involves around 20 clauses, from 2.01 to 2.20, and it primarily deals with appropriate means of escape in case of fire from the building to a place of safety outside (RIBAEnterprises, 2006). However, one cannot just model means of escape as one single escape route entity, as there are various entities which come under the concept of escape route in different contexts. Different objects are modelled as means of escape in fire situations and this is explained with the help of examples.

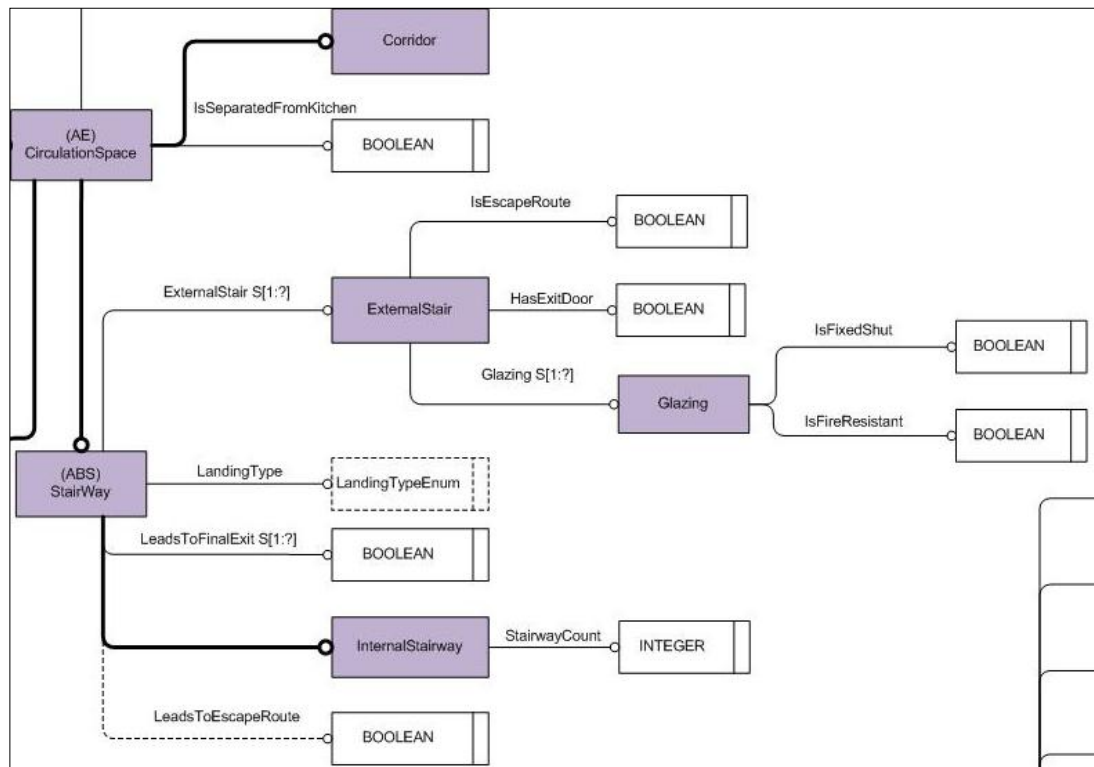

Figure 6.8: Representation of the abstract concept of means of escape

Figure 6.8, suggests, the entity STAIRWAY has subtypes EXTERNAL STAIR and INTERNAL STAIR, and STAIRWAY is attached with a simple data type Boolean attribute type suggesting whether or not it leads to a final exit. External stair has been attributed with a simple data type Boolean to know whether or not it acts as an escape route. External stair shows a relationship with exit door, or rather the external stair should have a door which acts as an exit point. This is represented using a simple data type Boolean.

Example-3: HabitableSpace

HABITABLESPACE is modelled as an entity class (see Figure 6.9) which has the subtypes SLEEPING SPACES, KITCHEN and HALLWAY. Habitable space is shown as having a

relationship with the entity DOOR and an attribute simple data type Boolean is attached showing whether or not it has an exit door. The habitable space entity is also represented showing an object to object relationship type with window. This relationship is shown in a very particular context, suggesting that a window can act as an escape route in emergency situations.

The entity HabitableSpace is represented to have an optional relationship with the entity new room, if the room is of a habitable type, as per the building regulations. If the new room is of a habitable type, it is provided with a final exit, but if not it is represented by a simple data type Boolean.

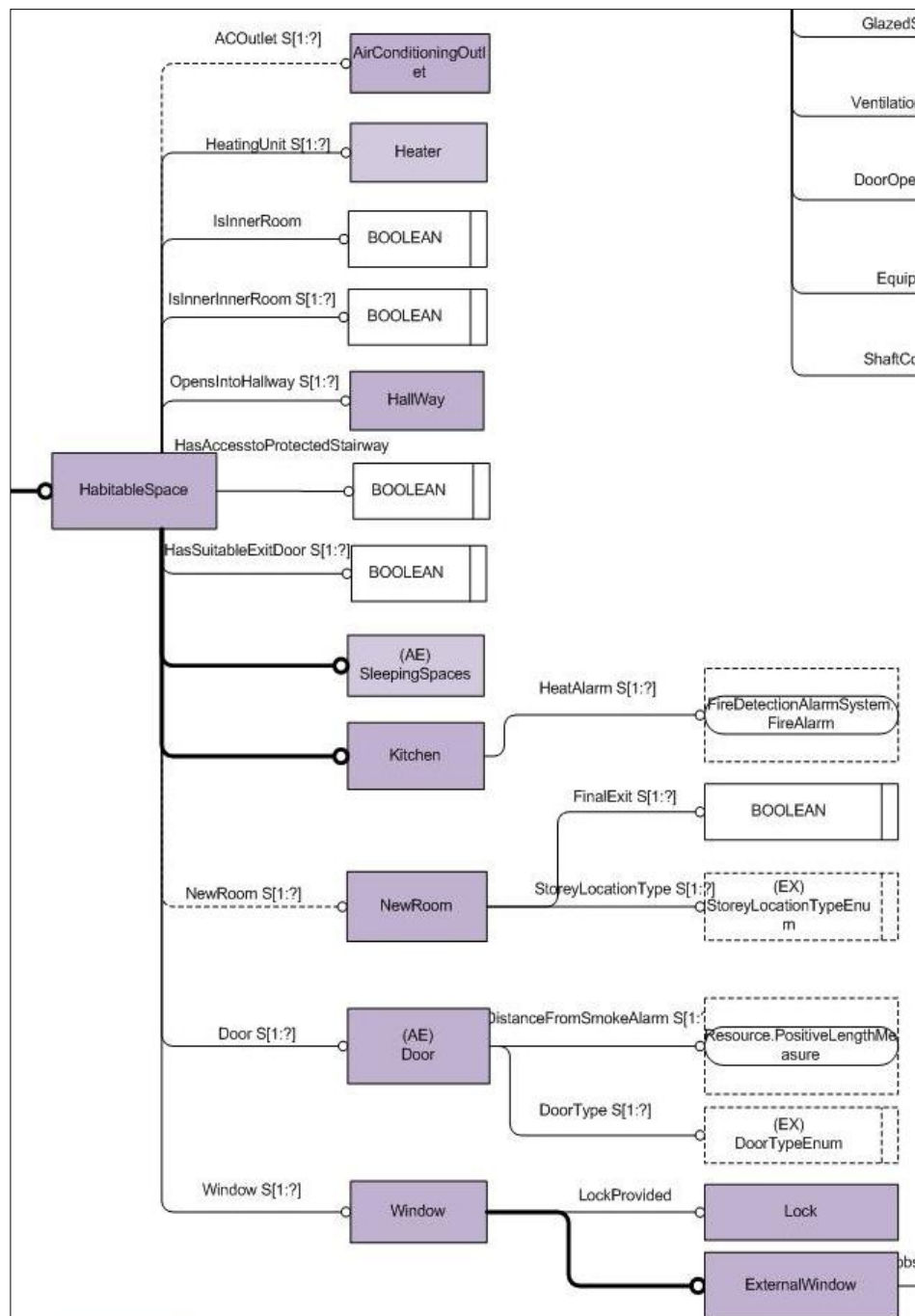

Figure 6.9: Representation of the abstract concept of habitable space

6.6 Strategies adopted and exceptions made

How different strategies were adopted during the UK building regulation specific object model development is explained here with examples which help with understanding the fire safety object model development. However, this particular data model was not developed by only using the above mentioned principles from section 6.3, as at times it was developed by making exceptions or by moving away from the usual principles. Such decisions were made using judgement and considered the requirements of automated compliance checking.

- Example
- The entity BUILDINGSITE has a relationship with WATERTANK. It could have been presented easily by using a simple Boolean type, but since the B1 clauses provide more information it has been represented as the entity WATERTANK, which has attributes such as volume measure.
- Whether or not a site should be provided with vehicular access is represented as the entity BuildingSite, which can have a simple data type Boolean suggesting whether vehicular access is provided or not. However, instead of a simple data type Boolean, it was decided to make vehicular access an independent entity. VEHICLEACCESS was therefore treated as an entity as it has to be represented in relation to door width, which is critical for the entry of high reach appliances (Figure 6.10).
- The entity FireAlarm has a simple data type attribute Boolean and is used in instances such as the fire alarm being in the kitchen, a fire alarm being on every storey, and a fire alarm being in circulation space.

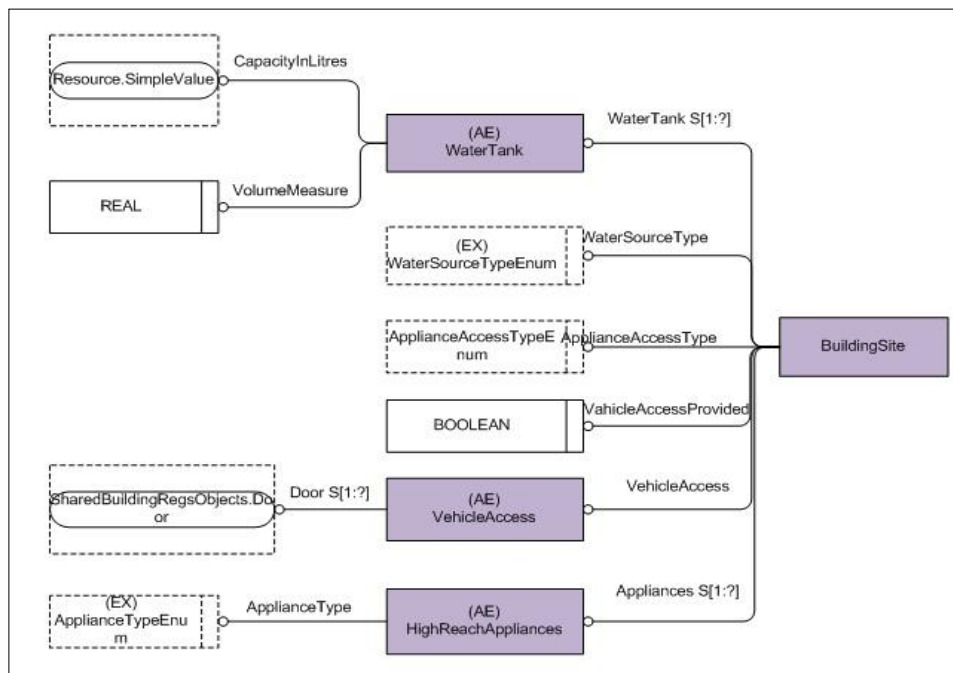

Figure 6.10: Entity class building site representations

6.6.1 Use of different simple data types

Example

- The entity CIRCULATIONSPACE is separated from kitchen is represented using a simple data type Boolean instead of showing an object to object relationship between circulation space and kitchen. The entity kitchen features in a more important object to object HabitableSpace-Kitchen relationship.
- Whether or not a building site has been provided with vehicular access is represented as a simple data type Boolean. The entity water tank volume measure is represented as a simple data type real number.
- Building occupants are represented as the entity person, and the occupant number attribute is joined using a resource simple value data type. Whether a person is at a special risk of fire or not is represented using Boolean.
- The entity external stair acts as an escape route is represented using Boolean. Whether an exit door is provided or not is represented using Boolean and stairway count is represented using an integer data type.

Thus, the UK fire safety EXPRESS-G based FireDetectionAlarmSystem object model has been developed. However, to develop the same object model further, it can be extended by considering the remaining 6 sections from the B1 fire safety clauses. With each new section new entity classes get added to the object model, resulting in a large entity–relationship model. It is not possible to explain in detail how the fire safety object model can be extended further in the form of object classes such as fire separating element, cavity barrier, fire rising mains, smoke vent, building, building storey, etc. By and large the same principles explained above were used to extend the object model further (see Appendix-IV). The B1 fire safety object model has been further divided into different domains after its complete development and this is explained in detail later in this chapter (see Appendix-V to view the complete B1 specific object model).

6.7 Structuring of object data model

6.7.1 Need for structuring

Using the above mentioned steps (section 6.2 – 6.4) the result was the development of the UK fire safety building regulation object model. It is an Express-G based entity-relationship information model which comprises various fire safety related entities organized into an object-based inheritance hierarchy. It was important to structure the developed building regulation specific data model in order to ensure the following (see Appendix-A):

- To classify it for better management (manageable chunks) and further growth.
- To classify it into suitable domain spaces.

- To make it modular for the development of model components, the model schemas.
- To easily integrate/map with the IFC data model.

The UK fire safety data model was developed with reference to the IFC data model and so was its structuring. The IFC object model was decomposed into smaller and more manageable modules which were interconnected by a rigid overall structure. It was important to structure the developed building regulation specific data model in order to ensure it was modular for the development of model components.

6.7.2 Methodology for structuring

As per the literature review, the structuring of the building regulation clauses was categorised on the basis of construction aspect. Similarly, the fire safety object data model was categorised into different domain spaces on the basis of the nature of classes. The structuring of the developed data model was based on the entity class's related character. Entity classes were grouped into domain spaces on the basis of their nature resemblance with the domain spaces (Salama & El-Gohary, 2011). Defining or arranging the whole object data model for the fire safety rules into different domains is now explained in detail using highlighted points.

- *Use of the IFC data model structure*

The IFC model has four different layers: 1) Core layer, 2) Resource layer, 3) Interoperability layer, and 4) Domain layer, representing four different levels. The IFC data model structure has been described previously in literature review where the layering system was described in section 3.4.1. Each layer has several categories and it is within each category that the individual entity is defined (Khemlani, 2004).

The UK fire safety object data model entities were divided into different domain spaces using the IFC domain structure as guidance. How the IFC layer structure was used as a reference is explained:

- Just as the IFC data model has specialist domain spaces to group similar specialist object classes into their respective domains, the developed model was also divided into specialist domain spaces.
- With reference to the IFC's interoperability layer, entity classes related to interoperability were grouped together.
- All resources, such as positive length measure and power supply types, were categorised into the resource domain just as in the case of the IFC data model.
- With reference to the IFC's kernel, all abstract entities were grouped together in the developed building regulation data.

- *Domain formation*

The overview of the data sample section given above describes in detail the makeup of fire safety volume B1, suggesting it possesses eleven different sections containing clauses about different aspects of building design and construction (B1 document). This leads to the conclusion that structuring of building regulations should be done on the basis of building design and construction aspects, not on the basis of the semantics they possess. The eleven different sections cover building design related aspects, such as fire detection and alarm systems, escape routes, wall and ceiling linings, load bearing elements of a structure, Compartmentation, concealed spaces (cavities), protection of openings and fire-stopping, construction of external walls, space separation, roof covering, and vehicular access (see Table 6.1).

If the complete EXPRESS-G model were to be deconstructed one would notice the formation of major entity classes such as FireDetectionAlarmSystem, Compartment, EscapeRoute, Cavity, External wall, Roof, Space, etc. This shows that different sections are similar or have a relationship with the entity classes from the EXPRESS model and that is due to the fact that a typical section focuses on one particular aspect of building design and that aspect gets turned into an entity class along with the relevant attributes.

Table 6.1: Resemblance between fire safety BReg sections and EXPRESS-G classes

	Fire Safety Volume B1 Sections	Prominent Corresponding Class
01	Fire detection and alarm system	FireDetectionAlarmSystem
02	Escape routes	EscapeRoute
03	Wall and ceiling linings	WallLining (product extension)
04	Compartmentation	Compartment
05	Concealed spaces	Cavity (Space)
06	Protection of openings and fire-stopping	Opening
07	Construction of external walls	External wall
08	Space separation	Space
09	Roof coverings	Roof

Observation of the resemblance between data sample sections and entity classes initiated the process of formation of suitable domain spaces to divide the developed data model into manageable parts. Specialist entity classes were grouped together in the specialist domain, such as FireProtection, StructuralElement, FireDetectionAlarmSystem, Space, Resource, FireProtection, etc. (see Appendix-A). Continuing with the same strategy of using the IFC model structure as a reference, all the entity classes related to interoperability were put together. Domains such as SharedBuildingObjects and ProductExtention were created to put together all

the commonly used objects, and to reuse them and make the model modular such interoperability related domains were created. In this way the developed data model was categorised into different domains which were suitable for integration with the IFC model. This shows that when a building regulation related section has a greater number of clauses it results in prominent class/classes having numerous attributes. The following are some examples (see Appendix-A):

FireDetectionAlarmSystem– FireDetectionAlarmSystem, Firealarm, Detector, Sprinkler System, Detection Equipment

Structural Element - Portal frame, Loadbearing structure,

SharedBuildingObjects– Roof Light, Flat roof, ceiling, window, lighting diffusers, thermoplastic material.

ProductExtention– building, building storey, building site, wall, and external wall.

FireProtection – Fire rising mains, Cavity Barrier, Fire separating element, Smoke vent, compartment, compartment wall.

- ***Formation and use of the resource domain***

The IFC model architecture consists of four layers, as mentioned in section 3.4.1, and one of them is a resource layer. The resource layer in the IFC model architecture appears as the lowest layer and it is the base class for resources. It can be used by classes or referenced by classes. IfcResource is subdivided into materials, labour, equipment, subcontracts, crews, and more. Resources present various costs and calendars of availability (Khemlani, 2004).

In the fire safety EXPRESS-G model, the resource domain is created for the same purpose and is used by classes and referenced by classes. The resource domain in this data model acts as the base class for resources. Resources can be characterized as general purpose or low level concepts, or objects which do not rely on any other classes in the model for their existence. For instance, information concerning the concept of length measure is represented as a positive length measure. Any class from other domain spaces can use positive length measure as an attribute or can be referenced to resource domain.

- Example –1

ENTITY Detector;

DistanceBelowCeiling: OPTIONAL PositiveLengthMeasure;

DistanceFromLightFitting: PositiveLengthMeasure;

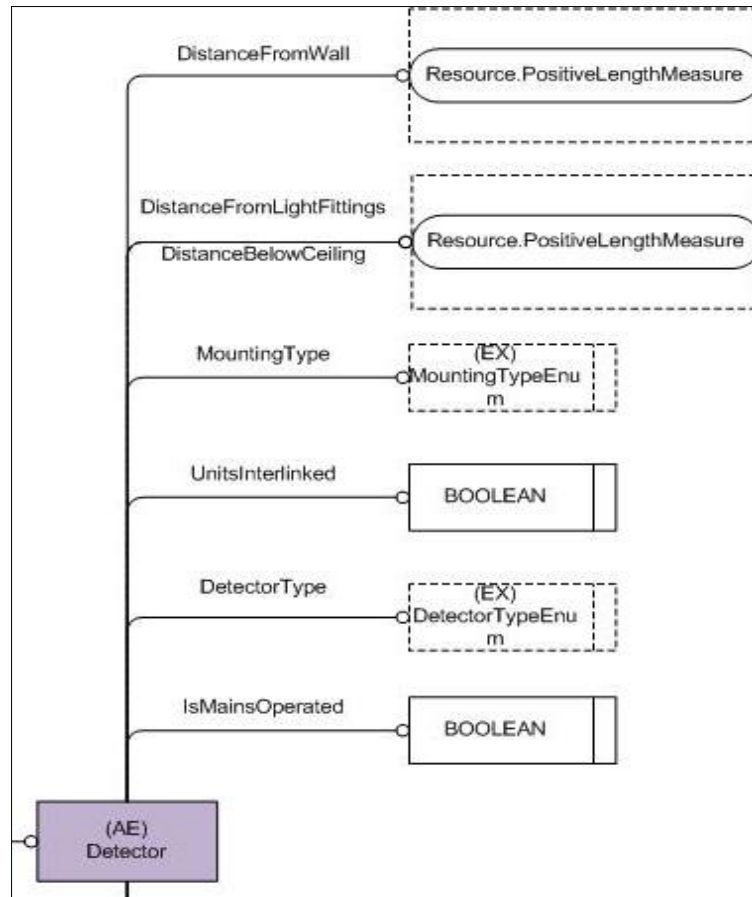

Figure 6.11: Use of attributes from resource domain

○ Example –2

With ENTITYDETECTOR, if it is ceiling mounted its sensor should be below the ceiling by a distance of 25-150mm. It has an optional relationship with the entity positive length measure from the resource domain. Entity SMOKEALARM/DETECTOR should be fixed away from the nearest light fitting; it has been presented as an entity POSITIVE LENGTH MEASURE from the resource domain (see Figure 6.11).

ENTITY FireAlarm;
 DistanceFromHabitableRoomDoor: PositiveLengthMeasure;

To find out or represent ENTITY SMOKEALARM/DETECTOR, if it is in circulation space it needs to be away from a habitable door by some numerical distance, which is represented as an entity POSITIVELENGTHMEASURE from the resource domain.

In this way the developed information model was categorised into different domain spaces, using the above mentioned strategies in section 6.7.2, to give it a modular structure and so that further development could be continued by targeting a greater number of clauses. Various observations were drawn out of this building regulation specific data model and they are explained in the next section.

6.8 Observations

After completing the fire safety B1 object model development, observations were drawn to justify its significance.

6.8.1 Interoperability

Two strategies were adopted to name the object classes observed during the object modelling, as explained below in section 6.8.1.

- *Use of standard terminologies*

The expectation and necessity for standardised concepts and terminology is on the increase in the construction and facility management sector. Internationalisation of the construction industry and an increasing use of information systems are decisive factors in this development. A generally agreed ontology is a prerequisite for effective information exchange and interoperability in any field of knowledge. The ontology for the construction and facility management sector comprises concepts for describing construction entities, their design, production and use, as well as people using and experiencing the built environment.

The construction and facilities management sector is traditionally national and regional in character. Currently there are two major international candidates for core ontologies, ISO 12006-2:2001 and IFC developed by the International Alliance for Interoperability. The IFC standard addresses interoperability requirements and has a similar scope concerning both construction and facility management. IFC consists of a framework of classes and models, intended to be used mainly for translating information between schemata in different object-oriented information systems, but also for development of schemas for such systems. Considering the extreme significance of IFC as an interoperability standard, its ontological standard needs to be followed, as well as the principle that "Entities should not be multiplied unnecessarily". So by acknowledging the above mentioned knowledge regarding interoperability, objects extracted using knowledge formalisation (described in the previous chapter) were modelled using terminologies that were the same as IFC wherever possible. The table 6.2 below shows the entities which resemble IFC entities.

Table 6.2: Extracted objects' resemblance to IFC objects

Express-G data model objects	IFC objects
Window	IFCWindow
Site	IFCSite
Storey	IFCSlab
Wall	IFCWall
FireAlarm	IFCAlarmType
Ceiling	IFCCeiling
Lining	IFCDoorLining
Circulation space	IFCSpace
Room Door	IFCDoor
Hydrant	IFCDuctSegment
Fire, rising main, Vent	IFCDuctSegment
Railing	IFCRailing
Portal frame	IFCStructuralMember
Staircase	IFCStairFlight

- ***Inconsistent class terminologies***

As building regulations are in a human linguistic format, entities or objectified concepts existing in them are terminologically inconsistent. Objects were therefore modelled with consistent terminologies to make them suitable for interoperability.

- Example –

Section 1; Fire detection and fire alarm system

As the name suggests, this deals extensively with provisions to be made in dwellinghouses to give an early warning in the event of fire. Throughout this section, entities related to fire alarm systems have been named differently, irrespective of their function. Entities related to fire alarm systems have been named inconsistently and due to this, modelling of such entities becomes ambiguous. After analysing this section and its clauses, it was noticed that entities involved in a fire alarm system were alarm, units, smoke alarm, detector, smoke detector, heat alarm, detection equipment, alarm receiving centre, heat detector, wall mounted unit, ceiling mounted unit, etc. It was technically incorrect to have general terminologies such as alarm, heat alarm and units; this caused difficulties in understanding the structure of the fire alarm system. To make it more streamlined and clear, it was important to understand technically how a fire alarm system is structured and why the same object/entity is used with different names in different clauses. After thorough analysis it was

decided to model detection and alarm system as an entity with an object to object relationship with detector, fire alarm, sprinkler system and detection equipment. The building regulation authors did not maintain consistency and used different building regulation related terminologies. They were used unceremoniously and this is why, while modelling entities, such entities were modelled with consistent terms.

6.9 Understandability

The developed building regulation specific data model is very specific.

- *Classes specific to UK building regulations*

The UK fire safety EXPRESS-G data model is structured on the lines of the IFC model structure. Also, several of the entity classes created is grouped into domains on the basis of their nature and they are very specific to the UK building regulations in terms of the use of terminologies. To be precise, some of the classes created are defined using terminologies which are used in the building regulation documents, which mean they show more resemblance to the UK building regulations than to IFC terminologies. In data modelling, knowledge is modelled in terms of units called entities or objects. An entity can be loosely defined as a thing that exists and is distinguishable. Some entities correspond to real-world objects while some entities are used as names for something else. As mentioned in section 6.8.1, some entities which are extracted correspond to IFC entities. However, some of the entities extracted are very specific to building regulations in their nature and character. These entities are UK building regulation specific and have enough attributes for them to be represented differently. Examples of such UK fire safety regulations specific classes are given below in section 6.9.

- Example – 1: Section 5 Compartmentation in the B1 technical document is a concept related to restricting the spread of fire by sub-dividing into compartments. As shown in the figure 6.12, the entity COMPARTMENT is a predominant class that is derived from this section. It has an object to object relationship with the entity COMPARTMENT WALL and the entity COMPARTMENT FLOOR. Class COMPARTMENT is a very unique entity class as it is UK building regulation specific and possesses attributes as per the B1 technical document. The same is the case for class COMPARTMENT WALL and class COMPARTMENT FLOOR; they can be subtypes of the generic wall and floor class, respectively. However, they possess attributes which are UK fire safety specific (see Figure 6.12).

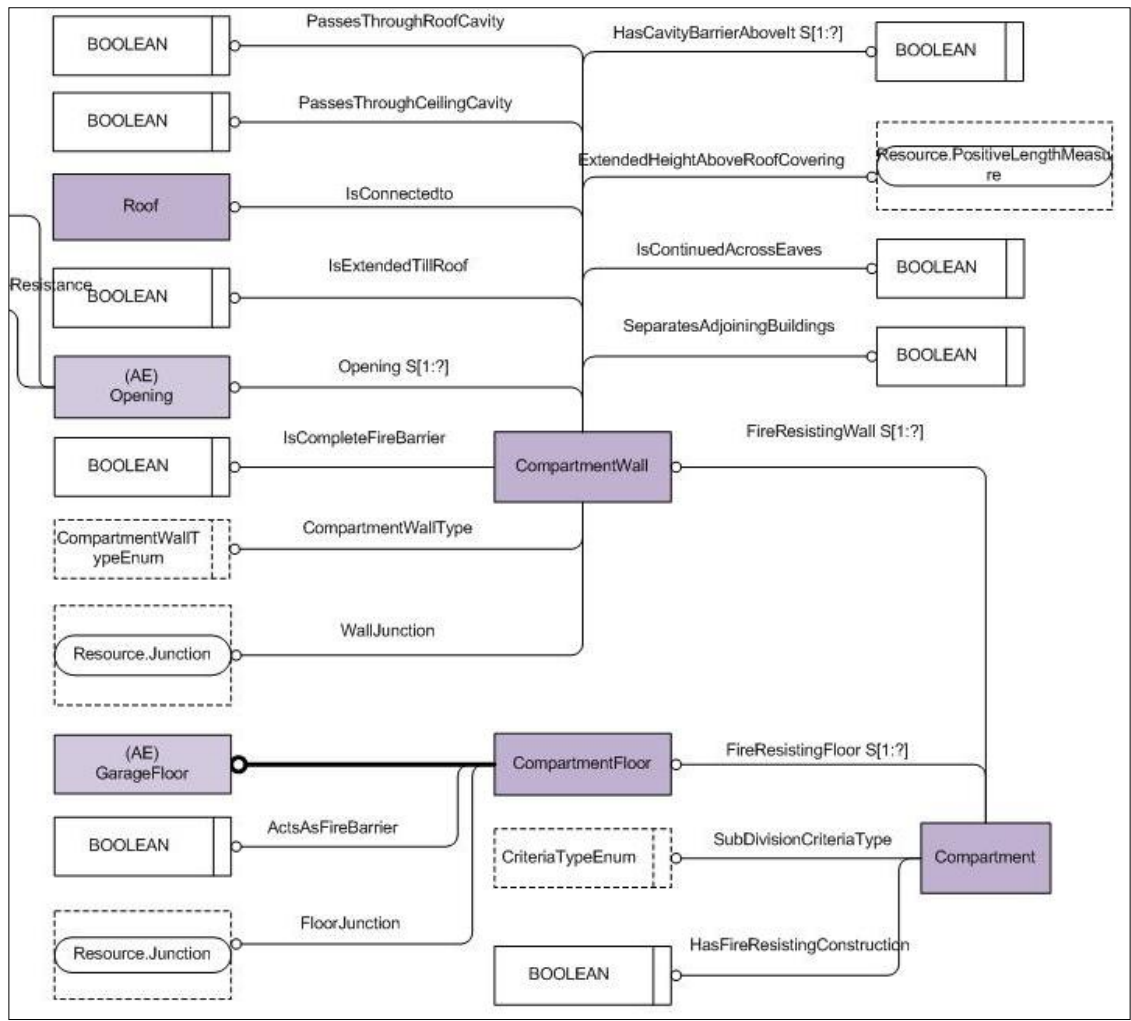

Figure 6.12: Entity relationship diagram for compartment class

- Example – 2: Cavity barrier in the B1 technical document is a concept related to restricting the spread of fire through cavities. As shown in the model, the generic space entity is related to cavity by an object to object type relationship. Entities cavity and cavity barrier are very building regulation specific classes and attributes are attached in that context. Class cavity barrier has been described in the following way (see Figure 6.13):

ENTITY CavityBarrier ABSTRACT;
 FireResistanceTime: INTEGER;
 FormsFireProofJunction: BOOLEAN;
 Has30MinsFireResistance: BOOLEAN;
 HasClasstype: ClassTypeEnum;
 IsMechanicallyFixed: BOOLEAN;
 IsTightlyFitted: BOOLEAN;
 LocationType: LocationTypeEnum;
 MaterialType: MaterialTypeEnum;
 OpeningLimitationTypeEnum;
 OpeningLimitationTypeEnum;
 SubdividesRoofSpace: BOOLEAN;
 END_ENTITY;

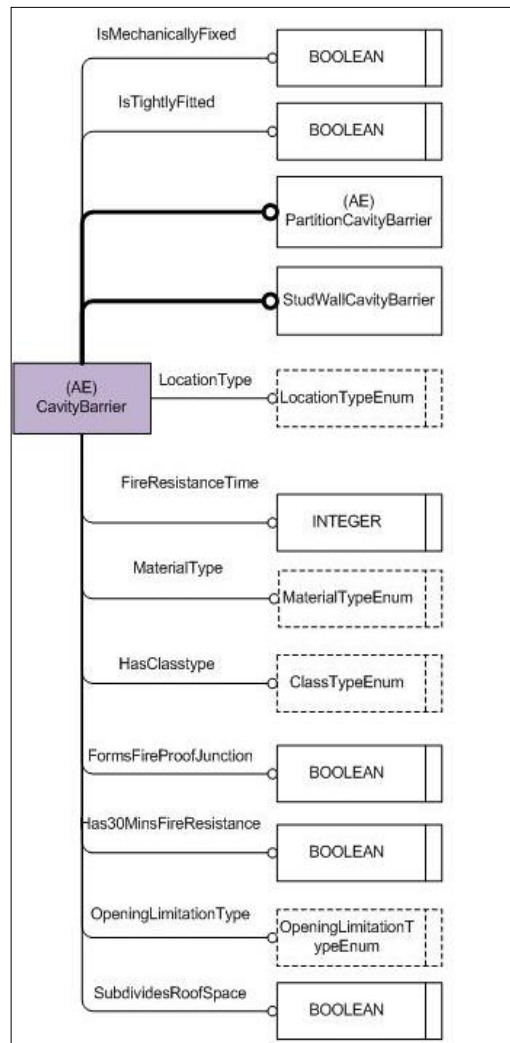

Figure 6.13: Class CavityBarrier (abstract) representation

Example – 3: Fire separating element is a unique entity class which has an object to object relationship with entities including joint, element opening, fire stopping system, sealing system, and service pipe. This is a class type which is very specific to building regulations and has been developed in the context of fire safety provisions (see Figure 6.14).

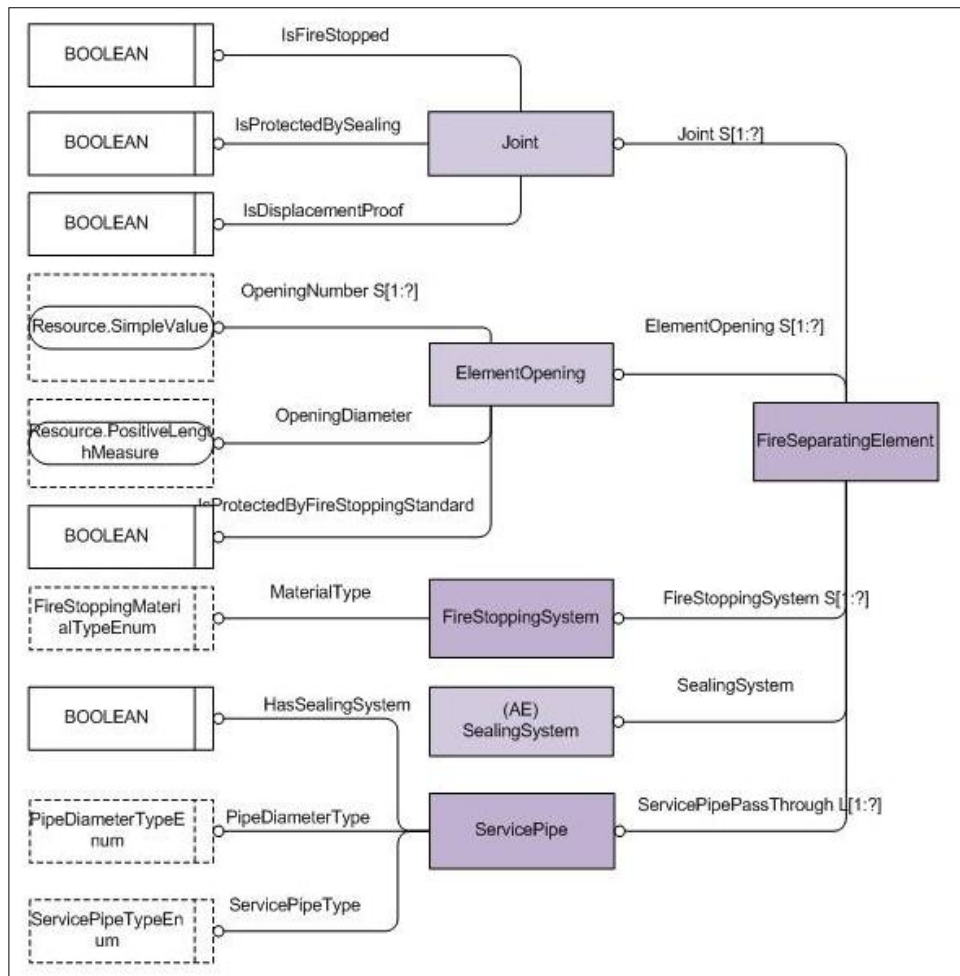

Figure 6.14: Class fire separating element representation

- ***Class definitions and building regulation sections***

In reference to section 6.6 above, the eleven different sections from part B1 include Fire detection and alarm system, Escape routes, Wall and ceiling linings, Load bearing elements of structure, Compartmentation, Concealed spaces (cavities), Construction of external walls, Space separation, etc. If the complete EXPRESS-G model were to be deconstructed one would notice the formation of major entity classes such as FireDetectionAlarmSystem, Compartment, EscapeRoute, Cavity, External wall, Roof, Space, etc., and their resemblance to the building regulation sections (see Table 6.3).

Table 6.3: Classes showing resemblance to building regulation sections

	Fire safety Volume B1 sections	Prominent corresponding class
01	Fire detection and alarm system	FireDetectionAlarmSystem
02	Escape routes	EscapeRoute
03	Wall and ceiling linings	Wall Lining (product extension)
05	Compartmentation	Compartment
06	Concealed spaces	Cavity (Space)
07	Protection of openings and fire-stopping	Opening
08	Construction of external walls	External wall
09	Space separation	Space
10	Roof coverings	Roof

6.10 Conclusion

The output of the knowledge formalisation process comprised disparate objects with their associated attributes. It was observed that all 122 objects reflected or were part of the fire safety object model. Hence, the resulting fire safety object model included relevant semantics for use along with the IFC standard for automated code compliance checking. Subsequently, this formalised knowledge was turned into an object model with the broad stages highlighted in section 6.1.

This chapter has described the development of a building regulation specific object model embodying concepts specific to England and Wales. Furthermore, the object model is England and Wales building regulation specific and has been developed in the context of fire safety regulations for dwellinghouses. It provides many more detailed entity definitions than are currently in the IFC schema. A significant number of these definitions are in reality a refinement of IFC definitions.

Example:

1. *'Habitable Space' or 'Circulation Space' is a refinement of 'IfcSpace'. These refinements can be modelled using Ifc decorator classes such as IfcClassification, IfcRelationships or the extensible IfcPropertySet mechanism.*
2. *The 'Detector' object is extracted from clause 1.15; it has been modelled as per the specific need of England and Wales building regulations. Relevant attributes like space containing a detector, distance of a detector from adjacent walls, and a detector's mounting type are associated with the entity detector. In this way a detailed 'detector' entity has been modelled as part of the object model and hence it is concluded that the object model provides many more detailed entity definitions than are currently in the existing IFC schema.*

Through inspection it is clear that many of the objects from the object model will be relevant to other parts of the building regulations, for example space model. The object model could be further extended by targeting a greater number of clauses from various parts and by enhancing commonly occurring objects. IFC object model architecture should be used as a guiding structure and has been used here to structure the UK fire safety object model in terms of defining domains, use of a resource domain and putting classes together in relevant domain spaces.

Example:

1. *Domains like 'SharedBuildingObjects' and 'ProductExtention' have been created to put together all the commonly used objects.*
2. *Specialist entity classes like 'Fire rising mains', 'Cavity Barrier', 'Fire separating element', 'Smoke vent', 'compartment', and 'compartment wall' are grouped together in a specialist domain, such as 'FireProtection'.*

A document modelling methodology was developed to model any England and Wales building regulation related legislative document. Steps or stages to be part of this methodology were designed in such a way that they would be applicable to different parts of the building regulations, i.e. part G and part C can be modelled using the methodology. This output of a modelling methodology can impact positively on the future of authoring technical documents for England and Wales building regulations. Such a methodology encourages authors to compose and write building regulations whilst keeping objects at the forefront. In this way building regulations will be ready and suitable for computer interpretation.

Mappings are to be created between the developed object model and the IFC model to achieve England and Wales building regulation specificity and an IFC compliant file which can be checked by MCS for automated compliance checking. The mappings will be done using the domain extensions approach, ensuring interoperability and maintainability. Interoperability has been ensured by modelling objects with terminologies that are the same as IFC. Also, to ensure that these mapping will have long term durability, the object data model has been structured the same as the IFC structure.

Validation of the Developed Methodology for Modelling

7.1 Introduction

The goal of this research work was to deliver a methodology which can demonstrate how a data-set from a building regulation legislation document can be modelled and authored to form a computable data model using an object oriented approach. The researcher not only wanted a data modelling methodology able to author any England and Wales building regulation document (e.g. Part B1, Part B2, Part G, and Part M) but also applicable to any generic legislative document in England and Wales. The development and execution of the document modelling methodology is explained in detail in chapters 5 and 6. As the methodology for modelling an England and Wales building regulation document has been developed completely, it needs to be validated to prove its applicability and authenticity. This validation is achieved by demonstrating its successful implementation in relation to a student residence house rules document for modelling and achieving desired results. This chapter explains what the main steps involved were and how the validation was achieved.

7.2 Summing up the document modelling methodology

The document modelling methodology was carried out in two parts, as explained sequentially in the previous chapters 5 and 6. Chapter 5 explains part one, knowledge formalisation, which resulted in formalised knowledge of the England and Wales fire safety building regulations. The output of the knowledge formalisation took the form of a significant number of disparate objects with their associated attributes. Chapter 6 explains part two, which utilised the formalised knowledge as a foundation for building the data model. Turning entities/objects into object classes and establishing relationships using an entity relationship method among such classes were the starting points for building the data model. Using this body of work, the IFC compliant England and Wales building regulation specific data model was developed. The formalised knowledge was turned into a data model for use by document authors and computer programmers. The document modelling methodology can be summed up in two parts, based on the previous two chapters (see Figure 7.1).

Part -1: Knowledge formalisation

- Selection of a legislative document - Selection of a legislative document as a sample using judgement sampling method that acted as a manageable part of the collected data, which was qualitative in nature.
- Use of a filter system - Classification of the selected sample data using the researcher's self constructed data filter system to determine which provisions were suitable for modelling (computer interpretable) and which were not.

- Extracting semantics- Decomposition of the selected data using semantic parsing or a data mining technique. Every possible entity featured in the selected data was identified and extracted.

Part-2: Development of data object model

- Development of the data model - The next step in the document modelling process was to develop an object based information model by specifying objectified classes along with their attributes. Objectified classes were defined on the basis of document context, significance and object related parameters. Using the following main steps the data model was developed.
 - Object identification
 - Object transformation into classes
 - Definition of attributes and enumeration values
 - Establishing semantic relationships

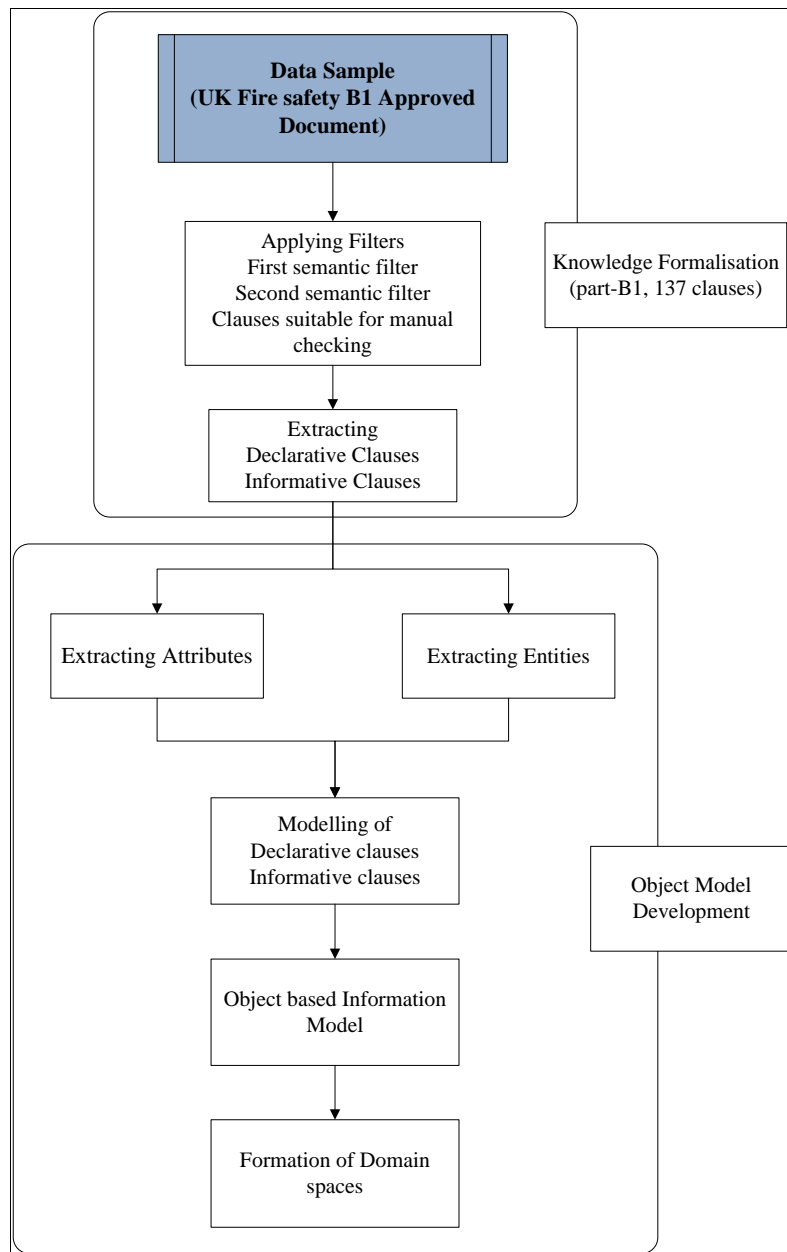

Figure 7.1: Legislative document modelling methodology

- Creating domains- To structure or arrange the developed data/information model into different domains, eventually turning it into a computer schema.

To validate the result, the model was exported to notepad and then the original legislative document was compared with the exported one, on the basis of the following parameters.

- Suitability for author rules/codes
- Relevance to industry needs
- Appropriateness for automated compliance
- Which one is more rigorous, consistent, clear and coherent?

The above mentioned work finally resulted in a methodology (see Figure 7.1) which was applicable for modelling any England and Wales building regulation document (e.g. Part B, Part G, and Part M) and it is expected to be applicable to any legislative document in England and Wales. So far it has been explained how the document modelling methodology was developed and how it could be used for fire safety document modelling. However, to prove its validity further it was applied to a generic document.

7.3 Validation by implementation

The developed methodology has been summed up in terms of how it may direct the future of authoring technical documents. At the same time, however, it was important to validate the methodology before its use. It was validated by showing its implementation on a generic document to achieve desired results. Implementation of the developed methodology started with part one, knowledge formalisation. The first step in this process was to select a document for modelling.

7.3.1 Selection of a generic document

To implement the developed methodology by modelling a document, the researcher considered a number of documents, such as Vehicle Driving Guidelines, Guidelines for Drinking-Water Quality, Grey water for domestic users: an information guide, Pavement Maintenance, Student Regulations - university accommodation, and National Parks and Access to the Countryside. These documents mainly stated certain rules or codes. Out of these a sample document was chosen entitled Student Regulations, incorporating the Code of Behaviour & Disciplinary Procedures. It basically explains regulations that students must follow during their stay in university accommodation. The student resident document was selected for data modelling and the house rules section was focussed upon as a manageable part to demonstrate the modelling methodology and its result.

- **Description of the selected document**

The document selected provides information to residents on a variety of issues, such as the code of practice, general student regulations, emergency powers and the student code of conduct. When students join the university to complete a degree course and they opt to live in university accommodation, the document, which comes in the form of a handbook, gives them guidance on a variety of topics. For document modelling purposes, the section representing house rules was selected as a sample (see Figure 7.2). The methodology developed as part of this research project was applied to achieve validation.

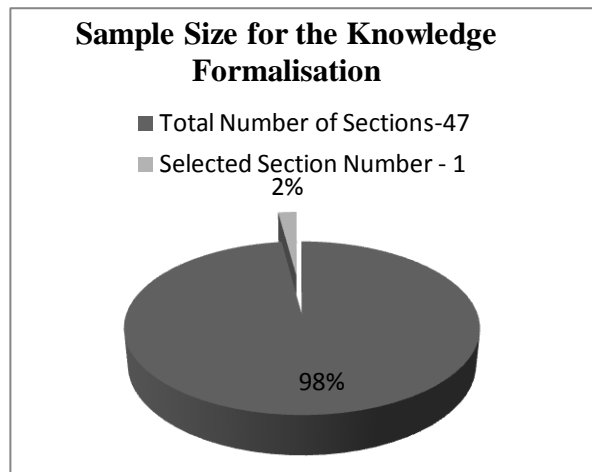

Figure 7.2: Selected sample size

The student resident document has in total 48 different sections giving information related to university accommodation. House rules was one of the sections selected for modelling. The house rules section comprises 40 rules and some of the rules are further divided into subsections. The house rules are for the safety and comfort of all residents and exist to ensure that everyone enjoys living in the residences. Student residents are bound by these rules and are expected to comply with them. Non-compliance with the rules by residents results in a warning or fine. The rules cover a variety of aspects, such as fire safety, property damage, security, domestic appliances, noise, social events, privacy, and criminal activity.

7.3.2 Use of a filter system

Once the sample data in the form of house rules was finalised, different filters were applied to classify the rules as part of the knowledge formalisation process. The section in total consists of 28 rules which residents are expected to abide by. The filter system explained in chapter 6 was used. The data filtering application was mainly concerned with data sorting; in this case, house rules were classified on the basis of their nature and they were put into different categories for rule modelling. The application had three data filters, filters one, two and three, to classify house rules into three categories: declarative, informative, and not suitable for modelling. These three data filters had different responsibilities and how they were used to categorise the rules is described below in section 7.3.2.

- **Filter one**

Using filter one, house rules which were declarative in nature and which were highly suitable for modelling were sorted out. Application of the first filter resulted in 18 declarative house rules being identified for further use in the object data model development. Some examples of these rules are given below.

Example:

- 4.1 *Cooking, in any form, is not permitted in bedrooms.*
- 4.3 *Keep all fire doors closed.*
- 4.5 *Candles are not permitted and will be removed by staff.*
- 4.8 *Emergency exits are to be used only in an emergency.*

- **Filter two**

The student resident guidance document includes a number of house rules which are subjective and involve natural language. They do not project a direct meaning; expertise is required to understand their exact meaning and to make it suitable for modelling. House rules sorted out using filter two were termed as informative rules as they possessed complex information and at times did not deliver a very direct meaning. The student resident guidance document features 16 such informative clauses (refer to Figure 8.4 below) which possess part data that was suitable for computer modelling; the remaining were unsuitable due to their prescriptive nature. Using filter two subjective, informative house rules were sorted out and rules were extracted. Some examples of such rules are presented below.

Example:

- 2.0 *Non residents should comply with the house rules is resident's responsibility.*
- 4.1 *Visitors are permitted to stay for a maximum of two nights in any seven.*
- 4.2 *You must respond to fire alarms by vacating the building.*

- **Filter three**

Filter three segregated data, i.e. house rules, which were not suitable for modelling. The filter sorted out rules which were very difficult to model and needed human judgement to extract the meaning. The student resident guidance document features 6 such house rules which were deemed not suitable for modelling. Using the data filtering system and by applying filters one and two, 18+16 house rules were separated. The remaining 6 house rules (refer to Figure 8.3 below) in the student resident guide document were deemed not suitable for modelling due to the subjectivity and ambiguity about their meaning. Also, such rules require human judgement to make meaning out of them. An example of such a rule is given below.

Example:

- 14.0 *Applications for social activities/parties involving more than four people at any time and more than one visitor after 23.00 must be made five weekdays (excluding bank holidays) in advance to the house manager.*

Using three different filters, the house rules were grouped into three sections. How they were distributed into the different categories is shown in Table 7.1.

Table 7.1: House rules grouped into categories using filters

Semantic Filter	Semantic Filter Brief	House rule numbers
First Semantic Filter	Computer interpretable information obvious for modelling	Rule - 01, 4.1, 4.2, 4.3, 4.5-4.9, 4.10, 4.11, 4.12, 4.13, 14, 16, 18,19,20,21,22
Second Semantic Filter	Information not obvious for modelling. Needs interpretation to understand the exact content and meaning.	Rule - 02,03,06, 07,08,10, 12,13, 17,23,24
Third Semantic Filter	Information which does not fit under declarative or informative categories.	Rule – 05, 09, 11, 14, 15.

The following pie chart (see Figure 7.3) indicates distribution of the total number of rules in each category.

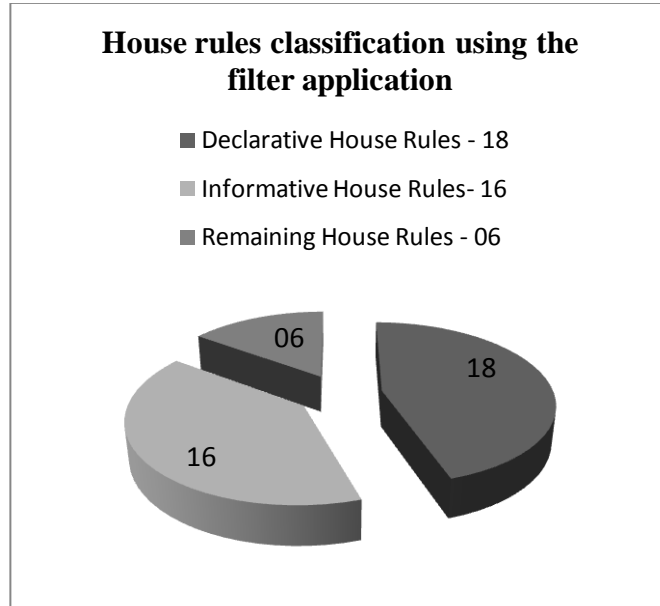

Figure 7.3: House rule categories along with total number

7.3.3 Extracting semantics

By using the filter system, once the declarative and informative type clauses were separated, they were further targeted to extract semantics. This involved extracting physical entities along with their given or derived attributes using a manual data parsing technique. In total, 34 house

rules came under the declarative and informative categories and these were targeted for semantics. From these 34 house rules, 40 entities were extracted or parsed out for use in the object data model development. University accommodation, resident, bedroom, entry, fire, heat detector, sauce-pan, and fire door were just some of the extracted entities from the declarative as well as the informative house rules.

Using three major stages (7.3.1 to 7.3.3), as explained above, the student resident house rule knowledge was formalised. Knowledge formalisation acted as a stepping stone for developing the object model. The object data model development began with use of the output from the knowledge formalisation stage. This output was in the form of 40 identified objects and their associated attributes.

Part-2: Development of the object data model

7.3.4 Development of the data model

The knowledge formalisation outcome comprised 40 disparate objects with their associated attributes. Primary entities parsed out from the filtered house rules (declarative type and informative type) initiated the development of the object data model. All 40 objects, such as heat detector, sauce-pan, fire door, windows, resident, bedroom, entry, fire, windowsills, fire alarm, waste pipes, candle, and fire exit, were considered for the data model development.

The next step was to establish the extracted objects in object classes for object data model development. This was done using the following important steps.

- *Object transformation into classes*

While modelling the student resident house rules, objects were established in object classes if relevant house rules provided considerable information about them in the form of attributes. Also, if the same object was described using various terminologies in different house rules, such differently named objects were modelled into a single class to represent it consistently, with various relevant attributes attached to it. In the knowledge formalisation process, where 28 house rules were considered, 40 different entities were identified and extracted, although not necessarily all of them were turned into object/entity classes. Establishing an object in an object class was completely based on the context of the house rules in which they appeared and their significance in the same.

The student resident house rules data model development started with a house rules section, focussing on the objects identified during the knowledge formalisation. Some of the objects identified included resident, bedroom, entry, fire, heat detector, sauce-pan, fire door, windows, windowsills, fire alarm, waste pipes, candle, fire exit, cooker, fridge, and equipment.

Noticeably, all of them (real or abstract) were not formally represented in the Express-G data development application as object classes. Only those that possessed important information in the form of attributes and which showed a relationship with other objects was represented as object classes.

Example – Objects extracted, such as fire door, kitchen, resident, and heat detectors, were considered for modelling. Once the entities were extracted, the attribute types were observed and noted from the house rules. To turn such extracted entities into classes, relevant attributes were associated with them. The entity kitchen was turned into a class by associating relevant information to it in the form of attributes. Information such as kitchen space contained heat detector, fire safety equipment, kitchen is separated from other spaces by fire doors, kitchen is provided with fire exists, and it should involve safe cooking using saucepans. All of this information was attached in the form of attributes. In this way the kitchen object class was developed and using Express-G modelling language it has been represented in Figure 7.4 below.

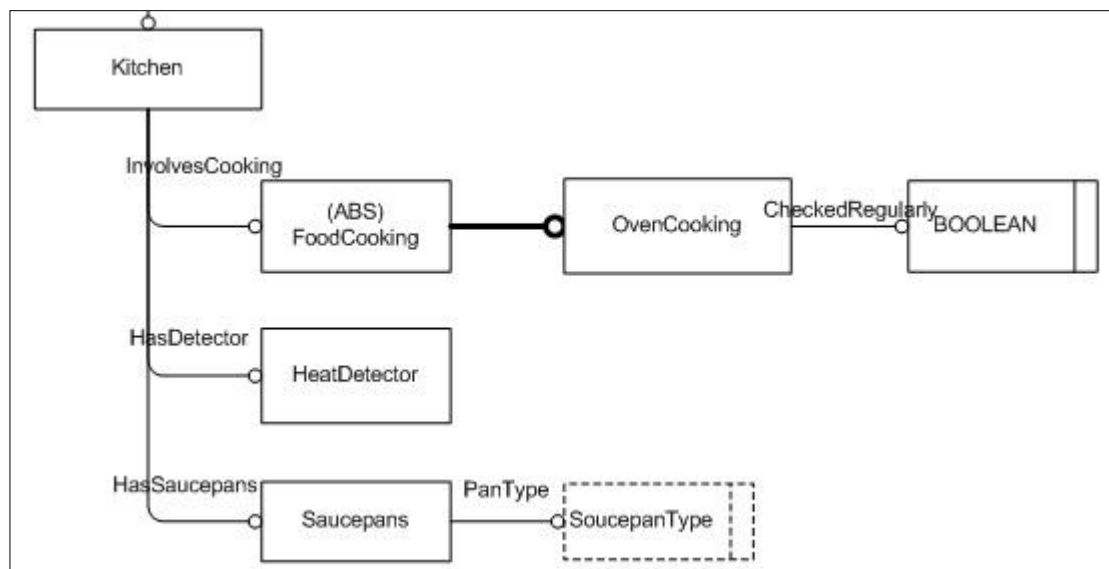

Figure 7.4: Entity classes including kitchen, food cooking, heat detector, and saucepan

- ***Establishing semantic relationships***

Once the student regulation specific object classes were established by attaching relevant attributes to them, the object modelling was extended by establishing entity-relationships between object classes. Relationships were established among the classes, primarily on the basis of the context in which they were mentioned. To establish them, different types of relationships were used and they are explained one by one with the help of examples from the data model in section 7.3.4 below.

- *Object to object type*

While modelling it was observed that entities or objects were related to each other on the basis of the rules in which they appeared. This relationship between objects was represented as object to object.

The house rules document suggests that university accommodation includes a kitchen and this was established as an object class. The accommodation consists of different space types, with kitchen being a habitable space as one such example. This was represented as the entity class kitchen. In reference to house rule numbers 4.1, 4.2 and 4.3, the class kitchen was shown to have an object to object type relationship with the class heat detector (see Figure 7.4). This relationship was represented as object to object and not in the form of simple data types. The reason for this was that entities such as kitchen and detector could be expanded further by turning them into classes as per the context of the student resident house rules. Residents are an integral part of accommodation and hence an object to object type relationship was established between the two.

- *Supertype-subtype*

In reference to house rule number 4.7, the entity OvenCooking was considered a subtype as it inherits all the properties of the class food cooking and entity FoodCooking acts as a supertype. OvenCooking inherits all the generic properties of FoodCooking but also possess additional properties like periodic checking. They both are contained by a space type named the kitchen entity (see Figure 7.4).

In reference to house rule number 4.8 (Emergency exits are to be used only in an emergency) and 4.9 (Fire exits must not be blocked) the entity FireExit was shown as a subtype and the entity Exits as a supertype. The context of house rules 4.8 and 4.9 indicated a supertype-subtype relationship and hence they were represented in that way (see Figure 7.7).

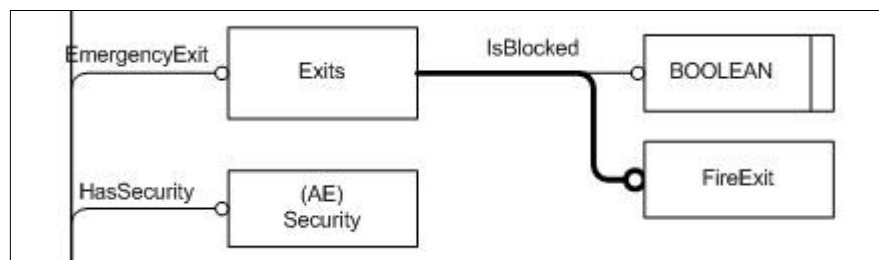

Figure 7.7: Supertype-subtype relationship between class Exit and class FireExit

- *Enumeration data type*

The use of an enumeration type allowed the data model to represent an attribute value in the form of a possible attribute. In reference to house rule number 4.6, to establish what type of sauce pan should be used for cooking purposes it was represented using an enumeration type so that the most suitable pan type attribute could be chosen from the possible values. Sauce pan type enumeration values were represented as follows:

Sauce pan type = ENUMERATION OF

(ORDINARY THERMOSTATIC);
END_TYPE;

In reference to house rule number 3.0, which suggests that non-compliance with the rules by residents, guests or visitors will result in a warning, fine, notice to quit or combination of these, these possible result values were represented in the data model using the enumeration type (see Figure 7.8).

Result Types = ENUMERATION OF

(WARNING,
FINE,
NOTICE);
END_TYPE;

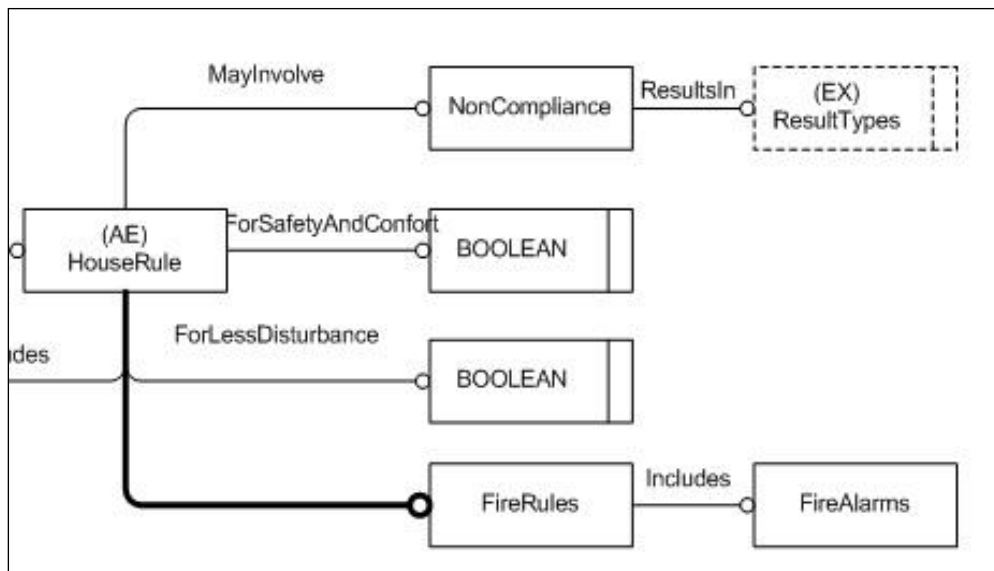

Figure 7.8: Entity Non-Compliance possesses result types enumeration values

7.3.5 Data model structuring

The above explains the work that resulted in the student resident house rules data model, which is an Express-G based entity-relationship information model (Hiekkila & Blewitt, 1992).

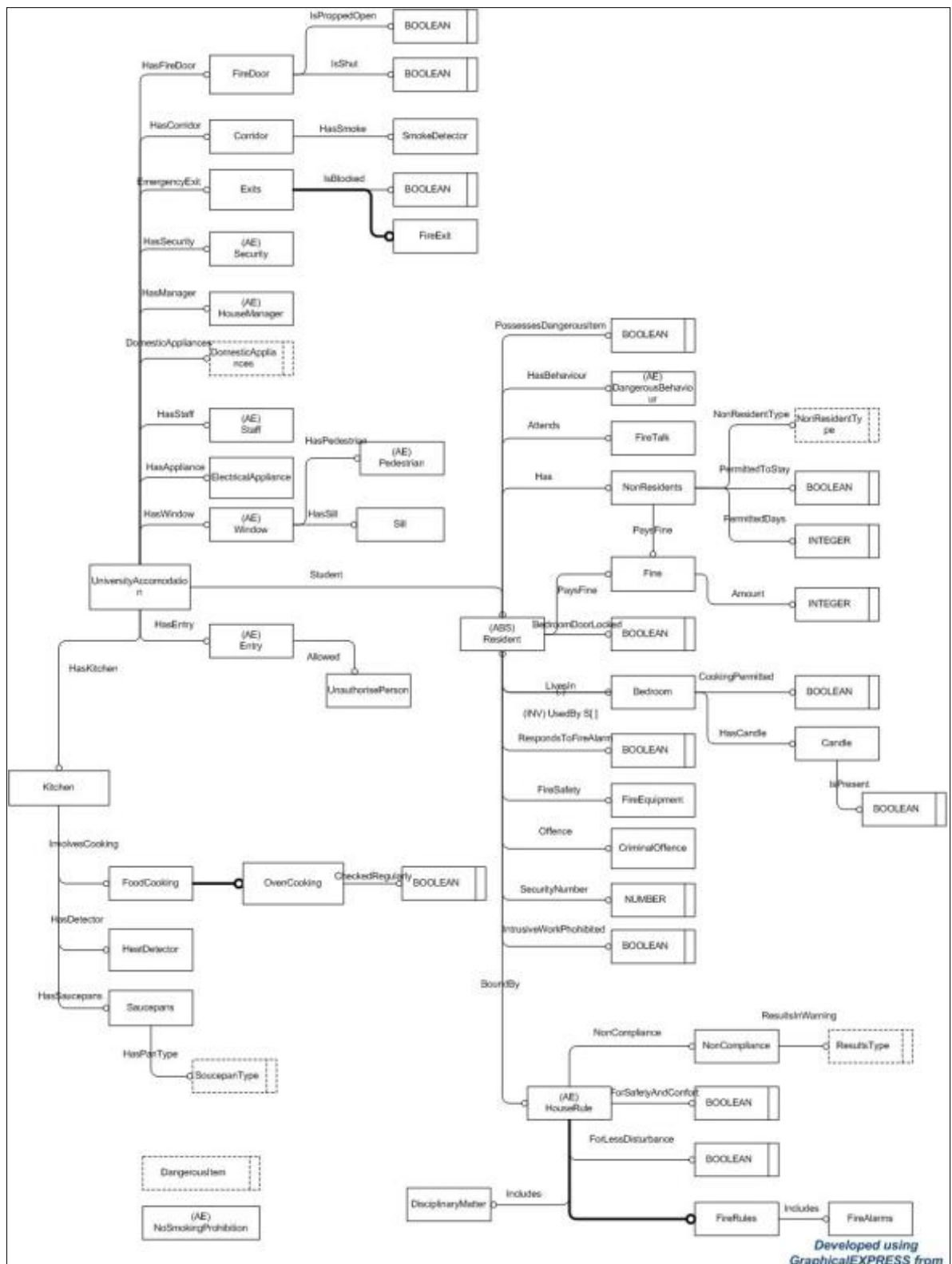

Figure 7.9: Student regulation specific data model

It comprises various house rules related to entity classes and is organized in an object-based inheritance hierarchy, as shown below in 7.3.5. It was important to structure the developed data model (as shown in above Figure 7.6) in order to ensure the following:

- To classify for better management (manageable chunks) and to allow for further growth.
- To classify it into suitable domain spaces.
- To make it modular for the development of model components, the model schemas.

Using the formulated principles, the data model was partitioned into different domains.

- ***Domain formation***

During the modelling process, domains were created by understanding classes along with their nature. Similar natured classes were grouped together to create domain spaces. Further domain spaces were also created on the basis of significant aspects highlighted by the house rules document, such as resident behaviour, fire safety, cooking, security, domestic appliances, and noise. Naturally, such significant aspects consisted relevant object classes along with attributes, hence to structure the data model, domain spaces were created on the basis of major aspects highlighted by the house rule document (see Table 7.2 below). Structuring or arranging the developed data/information model into different domains eventually led to a computer schema. Domain formation helped in making the model easy to understand and helped to ensure speedy navigation for users.

Table 7.2: Classes showing resemblance to building regulation sections

Sr no	Student resident house rules aspect	Prominent corresponding class
01	Resident behaviour	Class Resident
02	Fire safety	Class Exit, class fire door
03	Cooking	Food cooking
04	Security	Class security
05	Domestic appliances	Class Oven cooking, sauce pan

- ***Formation and use of the resource domain***

As mentioned in chapter 06, resources could be characterized as general purpose or low level concepts or objects which do not rely on any other classes in the model for their existence (Khemlani, 2004). In the student resident regulation model, resource domain was created and was used by student regulation specific classes, being referenced by the same. Resource domain

in this data model acted as the base class for resources. For instance, according to house rule number 1.13, student residents have to pay a fine if they make unreasonable noise. The fine amount varies and is represented using a simple data type integer from the resource domain (see Figure 7.10).

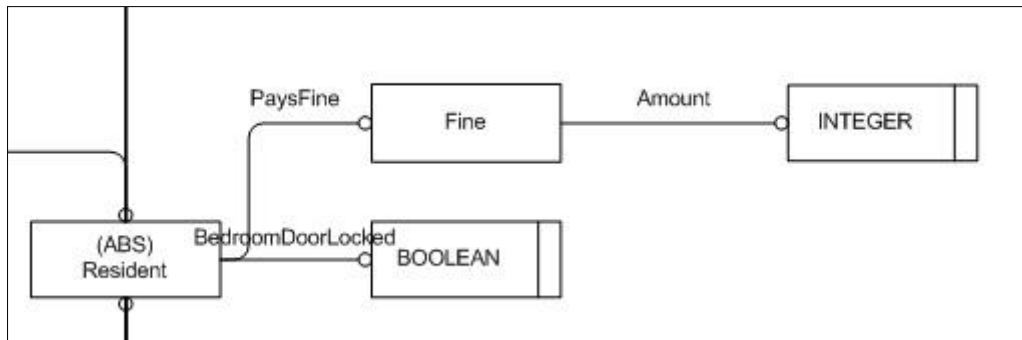

Figure 7.10: Use of Resource Domain

7.4 Conclusion

The methodology developed in this research for modelling a document was implemented to develop a student resident specific data model. The model was divided into domains, putting relevant classes together into respective domain spaces. This resulted in a modular structure for the data model and further development could be continued by targeting more resident rules. The IFC data model structure was used as a reference point to categorise the house rules data model into different domain spaces.

Noticeably, most of the objects parsed out from the house rules document as part of the knowledge formalisation were reflected in the EXPRESS-G object data model in the form of object classes. Research suggests that knowledge formalisation is essential before one can start the development of a document specific object model. It was not feasible to model all of the rules but the majority of the rules were suitable for modelling. In this way the methodology developed was successfully implemented to form a model general document regarding house rules for student residents, thus achieving validation.

Chapter-8:

Conclusions and Recommendations

8.1 Introduction

This chapter presents conclusions from the research undertaken in terms of its contribution towards theoretical knowledge, as well as its practical contribution towards further use of the IFC data model for automated building regulation compliance checking. It explains how far the contribution matches the objectives set at the beginning of this research project. Also, it explains the conclusions that have been drawn now that the objectives have been reached. The chapter ends by discussing the limitations encountered during the process and recommendations are made for further research, followed by closing remarks. The main aims of this research were to investigate the potential for digitisation of the England and Wales Building Regulations and to develop a method to construct an England and Wales building regulation specific object data model that enables automated compliance checking. In order to achieve these set aims, the researcher focussed on the objectives outlined in section 1.3. Throughout this thesis it has been explained how the set objectives have been achieved and, accordingly, appropriate conclusions have been drawn.

8.2 Conclusions

The primary goal of this research was accomplished by developing an IFC compliant England and Wales building regulation specific object data model to enable automated compliance checking. This IFC data model, along with BIM data, can be checked by MCS to enable automated compliance checking against rule sets developed using building regulation data.

In this thesis, a proposal has been presented which serves as a framework to model any UK building regulation legislative document (part A to P) and a fire safety building regulation specific object data model has been developed to support the process of automated compliance checking. The output has been the successful execution of all the objectives set at the beginning of the research. Conclusions have been drawn on the basis of this work.

8.2.1 Objective One - *to review England and Wales Building Regulations*

To make a shift from manual building regulations compliance checking to automated compliance checking, an understanding and analysis of England and Wales building regulations were of prime importance. The objective was to review the England and Wales Building Regulations in terms of their structure and composition and select an appropriate sample size. The study suggested that the Building Act 1984 is a key piece of legislation that applies to England and Wales and comprises the Building Regulations and Building Control system. Statutory requirements are published officially by the RIBA Enterprises in the form of Building Regulation Approved Documents. These approved documents, in total numbering 14 parts, consist of a different number of clauses, as shown in the table 8.1, below.

Table 8.1: Approved documents classification on the basis of building aspects

Parts	Description	Number of Clauses
Part A	Structure	82
Part B1	Fire safety	137
Part B2	Fire safety	445
Part C	Site preparation	128
Part D	Toxic substances	2
Part E	Resistance to sound (acoustic)	452
Part F	Ventilation	22
Part G	Hygiene	137
Part H v2	Drainage and waste disposal	368
Part J	Combustion and fuel	181
Part K	Protection	52
Part L1A	Conservation of fuel and power	83
Part L1B	Conservation of fuel and power	73
Part L2A	Conservation of fuel and power	104
Part L2B	Conservation of fuel and power	109
Part Mv2	Access	222
Part N	Glazing	19
Part P	Electrical safety	53
Total number of clauses		2669

It was observed that the England and Wales Building Regulations ‘Approved Documents’ consist of clauses that are written in a natural linguistic format. They represent complex, subjective information. Hence, it was concluded that in their present form they are not suitable for automated compliance checking. They, by their nature or characteristics, make the transition to automated compliance checking a difficult process.

This understanding of building regulations characteristics helped in realising that not all the regulations are suitable and therefore classification is required. Hence, to check compliance of building designs against building regulations automatically, it was necessary to carry out classification to find out which building regulations should be considered for automated compliance checking and which should be performed manually. This situation gave rise to the need for classification of the UK building regulations.

An overview and understanding of structuring of England and Wales building regulations showed there are, in total, 2669 clauses in 14 approved documents. It was not possible to

consider all the clauses available and classify them so an appropriate sample was selected. The Approved Document Part B1-Fire Safety was considered as part of the sampling process. It provided representative data to extract semantics for the data model development. For testing, small sections of the building code with fire requirements were targeted, and using filters at different stages suitable data was extracted.

8.2.2 Objective Two - *A critical review and a comparative analysis*

The review of England and Wales building regulations clarified that not all building regulations are suitable for automated compliance checking and a classification was therefore required to identify suitable regulations. Furthermore, it was decided that various efforts related to automated compliance checking would be studied. The objective was to conduct a critical review of various code compliance related implementation efforts undertaken in different countries. These various systems, such as CORENET, Statsbygg, DesignCheck, and ICC/GSA, were studied and interpreted (see Figure 8.2), with data collected in the form of web based case studies, which were recorded and documented. The objective helped in developing a consolidated summarised view of the entire various rule checking systems.

The consolidated view presented in section 2.3 (see Figure 2.3) helped in understanding how these systems work, and what the similarities and differences are between them. Furthermore, the following conclusions were made based on the reviewed work:

- All rule checking systems use IFC as an interoperability standard. Although there are several open standards for building models, IFCs are the most comprehensive for the purpose of regulatory control.
- All rule checking systems use different CAD packages, such as Revit, Archicad, Tekla, and Triforma. However, they all are exported into IFC as a neutral data format for checking.
- CORENET comprises an independent platform, FORNAX, along with the already existing EDM model checker. The EDM model checker is also part of rule checking systems such as DesignCheck and Statsbygg. The SmartCodes project from the ICC/GSA comprises SMC and XABIO as part of its rule checking system.

The critical review also helped in gathering data which was used for comparing all the various systems with each other in order to draw conclusions. Comparative analysis is presented in section 2.4, table number 2.1.

- All review systems have typically addressed only certain aspects of their overall system. Also, almost all systems are still in development and work is documented as ‘in progress’.

- It can be observed that most of the initiatives outlined above have focussed on creating object based rules and mapping the entities encapsulated within them to the international building model schema. However, this schema is designed to support the needs of an international user and takes little consideration of national semantics.

Using a consolidated view and detailed study of all rule checking systems, it has been concluded in section 2.4 that the four main functionalities required for rule checking.

8.2.3 Objective Three - to review *BIM and IFC*

After fulfilling objective two, four main functionalities were concluded and the role of BIM and IFC was introduced in the automated building regulations compliance checking. Due to this it was essential to explore how BIM and IFC could be used in the UK building regulation compliance checking context. Through objective three, the importance of preparation or authoring of a building model to make use of it in the UK automated compliance checking process was established. Also, it highlighted the significance of IFC as an interoperability standard for building model vendors, as well as its use in automated compliance checking. The following has been concluded:

- From an automated building regulation perspective, additional focus is required on the process of building model authoring by design teams to incorporate more and more information related to building regulations into building models. One of the significant hurdles for this process is that no single software application can claim to have the capability to fully populate building regulation related data in a building model. At present the focus of building model authors is largely on visualisation rather than building information and they are partly helpless in terms of making models more semantically rich due to the incapability of software applications to allow the same.
- As a result, current BIMs are not semantically detailed enough for use in the automated building regulation compliance checking process. Thus, to extend this information into building models or to make more building information available for the compliance checking process, an IFC-compliant England and Wales building regulation specific object model was required.
- In the context of automated compliance checking, model authors are not focussing on adding the required England and Wales building regulation specific information as it is not the established practice yet. If they want to, software applications must be developed that help them to do so. Model authors also need help with producing formalised data from the building regulations that are readily available so that they can include them in their building models.

Through a thorough IFC related review the following has been concluded:

- IFC standards act as international standards for interoperability, as they focus on universal standards. The existing IFC model has defined many universal AEC objects for use with AEC applications, which indicates that the IFC data model is rich in its semantic content. However, it does not represent entities or attributes which are important in the local context of UK automated compliance checking.
- It has a complex hierarchical structure and relations established between objects are not necessarily suitable for the UK automated compliance checking needs.
- This research concludes that international CAD tools should be employed to author the majority of building models in the form of elements, materials, geometry, etc., and an extension programme is a must for author data which is missing. There are several open standards for building models but our research to date has suggested that the most comprehensive, for the purpose of regulatory control, are the IFCs. Other standards, such as CityGML and GBXML, are targeted towards specific use and do not model the breadth of concepts required. The IFCs are also widely adopted by the major CAD vendors and are generally accepted as the standard most likely to succeed.

8.2.4 Objective Three – *to optimise the extraction of computer interpretable rules*

It was concluded in section 8.2.1 that not all building regulations are suitable for automated compliance checking. Furthermore, it was not possible to consider all the clauses available and classify them so an appropriate sample was selected. The next objective was to determine the suitability of a selected fire safety building regulations sample and optimise its suitability for use in the automated compliance checking using a knowledge formalisation process. The suitability was determined using a filter system, part of knowledge formalisation, and by understanding problems associated with the England and Wales building regulations for computer interpretable rules regarding code compliance checking. For optimisation it was important to overcome these problems. Optimisation was achieved through the process of knowledge formalisation developed as part of this research.

To convert the England and Wales building regulation knowledge into a computer interpretable rules format, a method in the form of knowledge formalisation was developed in this research. The process of knowledge formalisation showed how to overcome the transition related problems described beforehand. As stated in section 8.3.3 above, building models do not contain semantically rich information. To address this issue it was concluded that an object based representation of England and Wales building regulations would help to add value to building models. This object based representation would start with knowledge formalisation and hence it has been concluded that knowledge formalisation is essential before starting to develop a building regulation specific object model.

Using knowledge formalisation, over 350 semantic entities were identified from parts B1 and B2 of the England and Wales Building Regulations. It was observed that many of these entities, for example the space model, had relevance to other parts of the regulations. However, it was concluded that creating formalisations of regulatory information would generate many more detailed England and Wales specific entity definitions than are currently in the IFC schema. A significant number of these definitions are, in reality, refinements of IFC definitions. For example: 1) “Habitable Space” is a refinement of “IfcSpace”; 2) “Circulation Space” is a refinement of “IfcSpace”. Currently, it may not be feasible to write computer interpretable rules for 100% complete automated compliance checking. Nevertheless, a significant number of building regulations are suitable for automated compliance checking. The process of knowledge formalisation helps in estimating the number of declarative clauses. Furthermore, it has been concluded that a specific focus on automating the process for the declarative clauses in Part B1 could have significant benefits for the industry as highlighted in section 5.8. Further this objective helped in achieving the knowledge formalisation process through the major stages as mentioned in section 7.2 (see Figure 7.1).

8.2.5 Objective Four – *To develop England and Wales building regulations*

Through the previous objective the knowledge formalisation process was formed and executed. The next objective was to utilise the output from the knowledge formalisation and develop an England and Wales building regulation specific object data model suitable for automated code compliance checking. The output of the knowledge formalisation process comprised disparate objects with their associated attributes. It was observed that all 122 objects reflected or were part of the fire safety object model. Hence, the resulting fire safety object model included relevant semantics for use along with the IFC standard for automated code compliance checking. This formalised knowledge was subsequently turned into an object model with the following broad stages as mentioned in section 6.1.

The object model developed is England and Wales building regulation specific and has been developed in the context of fire safety regulations for dwelling houses (see Figure 7.1). It provides many more detailed entity definitions than are currently in the IFC model. A significant number of these definitions are in reality a refinement of IFC definitions.

Example:

3. *‘Habitable Space’ or ‘Circulation Space’ is a refinement of ‘IfcSpace’. These refinements can be modelled using Ifc decorator classes such as IfcClassification, IfcRelationships or the extensible IfcPropertySet mechanism.*
4. *The ‘Detector’ object is extracted from clause 1.15; it has been modelled as per the specific need of England and Wales building regulations. Relevant attributes like space*

containing a detector, distance of a detector from adjacent walls, and a detector's mounting type are associated with the entity detector. In this way a detailed 'detector' entity has been modelled as part of the object model and hence it is concluded that the object model provides many more detailed entity definitions than are currently in the existing IFC schema.

Through inspection it is clear that many of the objects from the object model will be relevant to other parts of the building regulations, for example space model. The object model could be further extended by targeting a greater number of clauses from various parts and by enhancing commonly occurring objects. IFC object model architecture should be used as a guiding structure and has been used here to structure the UK fire safety object model in terms of defining domains, use of a resource domain and putting classes together in relevant domain spaces.

Example:

3. *Domains like 'SharedBuildingObjects' and 'ProductExtention' have been created to put together all the commonly used objects.*
4. *Specialist entity classes like 'Fire rising mains', 'Cavity Barrier', 'Fire separating element', 'Smoke vent', 'compartment', and 'compartment wall' are grouped together in a specialist domain, such as 'FireProtection'.*

To fulfil this objective a document modelling methodology was developed to model any England and Wales building regulation related legislative document. Steps or stages to be part of this methodology were designed in such a way that they would be applicable to different parts of the building regulations, i.e. part G and part C can be modelled using the methodology. It has been concluded that this output of a modelling methodology can impact positively on the future of authoring technical documents for England and Wales building regulations. Such a methodology encourages authors to compose and write building regulations whilst keeping objects at the forefront. In this way building regulations will be ready and suitable for computer interpretation.

Furthermore, it was observed that mappings should be created between the developed object model and the IFC model (see Figure 8.1) to achieve England and Wales building regulation specificity and an IFC compliant file which can be checked by MCS for automated compliance checking.

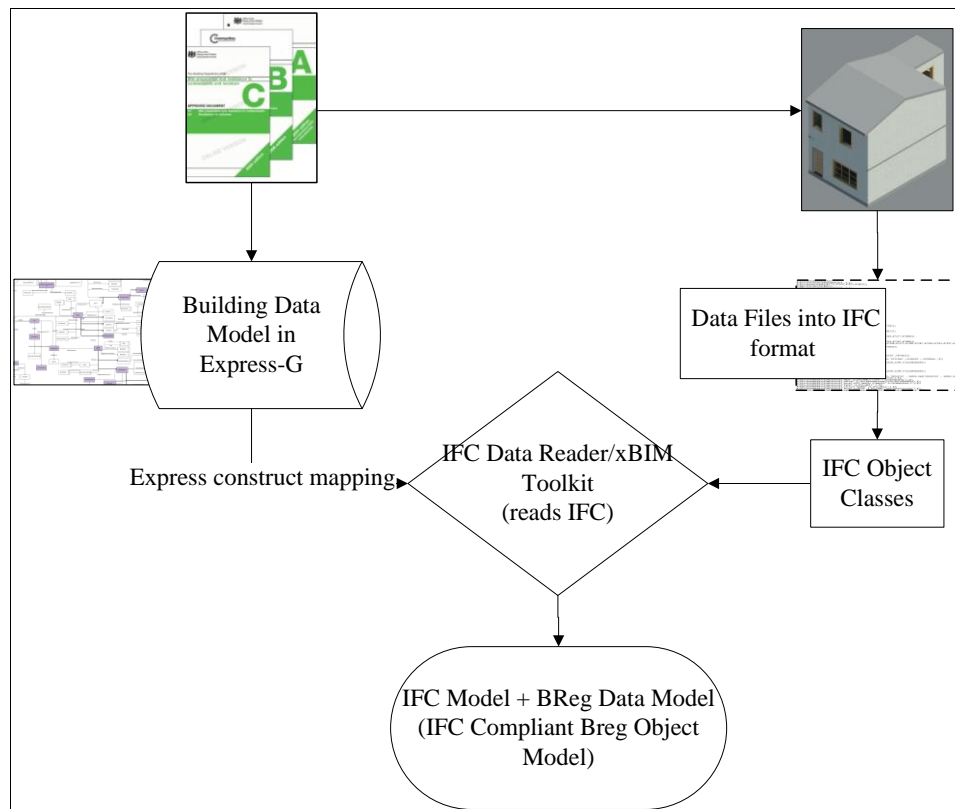

Figure 8.1: Mappings using the domain extensions approach

The mappings were done using the domain extensions approach, ensuring interoperability and maintainability. Interoperability was ensured by modelling objects with terminologies that are the same as IFC. Also, to ensure that these mappings would have long term durability, the object data model can be structured the same as the IFC structure.

8.2.6 Objective Five – *To validate the developed modelling methodology*

Objective four led to the development of a building regulation document modelling methodology. After this it was important to validate the developed methodology to prove its authenticity. Hence, it was implemented on a student regulation document to develop a student resident data model. The model was divided into domains, putting relevant classes together into respective domains, providing a modular structure. The data model could be developed further by targeting a greater number of resident rules. The IFC data model structure was used as a reference point to categorise the house rules data model into different domain spaces.

As part of the conclusion it was observed that most of the objects parsed out from the house rules document as part of the knowledge formalisation, reflected in the EXPRESS-G object data model in the form of object classes. Furthermore, it was concluded that knowledge formalisation is essential before one can start the development of a document specific object model. It was not feasible to model all the rules but the majority of the rules were suitable for

modelling. In this way the methodology developed was successfully implemented to form a general model document regarding house rules for student residents, thus achieving validation.

8.3 Contribution to Knowledge

This research was of an interdisciplinary type in which various disciplines were involved, including building regulations and their format, technical developments in CAD systems, interoperability, object modelling, existing automated compliance checking systems, etc. While conducting the research, various issues were covered, such as the unsuitability of building regulations for automated compliance checking, the lack of required data in BIMs, the incapability of software applications to build information rich models, interoperability issues, etc., and solutions were developed for these issues. While carrying out the work, several key contributions to knowledge were made and these are explained.

UK Statutory Requirements are published officially by RIBA Enterprises in the form of Building Regulation Approved Documents. RIBA Enterprises, the official publishers, have a vision to deliver building regulation standards in a more applicable manner and in accordance with the industry's needs. However, it was observed that the England and Wales Building Regulations 'Approved Documents' consist of clauses that are written in a natural linguistic format, as mentioned in section 5.3. They represent complex, subjective information. Hence, it was concluded that in their present form they are not suitable for automated compliance checking. They, by their nature and characteristics, as mentioned in chapter 05, section 5.3.1, make the transition to automated compliance checking a difficult process.

To overcome the issues and to achieve suitably formalised knowledge of building regulations, a concept of knowledge formalisation was introduced and developed. The basic aim of knowledge formalisation in the context of UK automated compliance checking is to interpret a body of building regulation knowledge and convert it into a computer application processable format, in such a manner that the implementation can be validated as being consistent with the original written knowledge. The development of a knowledge formalisation concept is a contribution to knowledge and using this knowledge technical document authors can deliver improved approved documents for compliance checking. It can help in increasing the suitability of technical documents for automated compliance checking. Building model authors will also benefit as they need help with producing formalised data from building regulations that are readily available so that they can include them in their building models.

Due to the unsuitability of the approved documents it was decided to optimise their viability for use in automated checking. The study undertook this challenge and it resulted in the development of a methodology for modelling a technical document (e.g. Part B1, Part B2); the methodology was designed in a way that it is applicable to all parts (e.g. Part G, Part M) of the

England and Wales building regulations or to any similar legislative document which has a human linguistic format.

By using this methodology, building regulation data decomposition was achieved. By using Express-G language along with an object oriented approach, a building regulation specific object data model was generated. This development of a generic document modelling methodology is another contribution to knowledge, as rule authors can use it for modelling the remaining parts of building regulations. By following the developed sequential steps, the said methodology was implemented on a sample legislative document to check its usefulness. Computer programmers can also benefit from this methodology as approved documents can be appropriately modelled and information extracted out of them can be much simpler due to this development.

It was noted that IFC standards act as international open standards for interoperability, as they focus on universal standards. The existing IFC model has defined many universal AEC objects for use with AEC applications in architectural design, cost estimation, building service design, construction, and facility management. This indicates that the IFC data model is rich in its semantic content. However, through this research it was concluded that it does not represent entities or attributes which are important in the local context of UK automated compliance checking. It has a complex hierarchical structure and relations established between objects are not necessarily suitable for the needs of automated compliance checking. This necessity of modelling national entities in the local context, as per the requirements and its execution (e.g. entity detector), is yet another contribution to knowledge that shows a way forward for people regarding how to model entities to achieve compliance checking.

The methodology developed for modelling an approved document is explained in section 7.2, which is one of the significant original contributions to the knowledge as part of this research. Further, this research work was extended to form a conceptual overview of stages involved in automated compliance checking (see figure 8.2). This conceptual framework is created on the basis of various conclusions drawn as part of the research (see in section 8.2.1-8.2.6). As mentioned previously in section 2.2.7, there has not been any direct effort towards automated compliance checking of UK building regulations. Formation of such a stage wise process or framework leads to an original contribution to knowledge. It provides an insight of how a transition can take place from manual checking of building regulations to automated compliance checking.

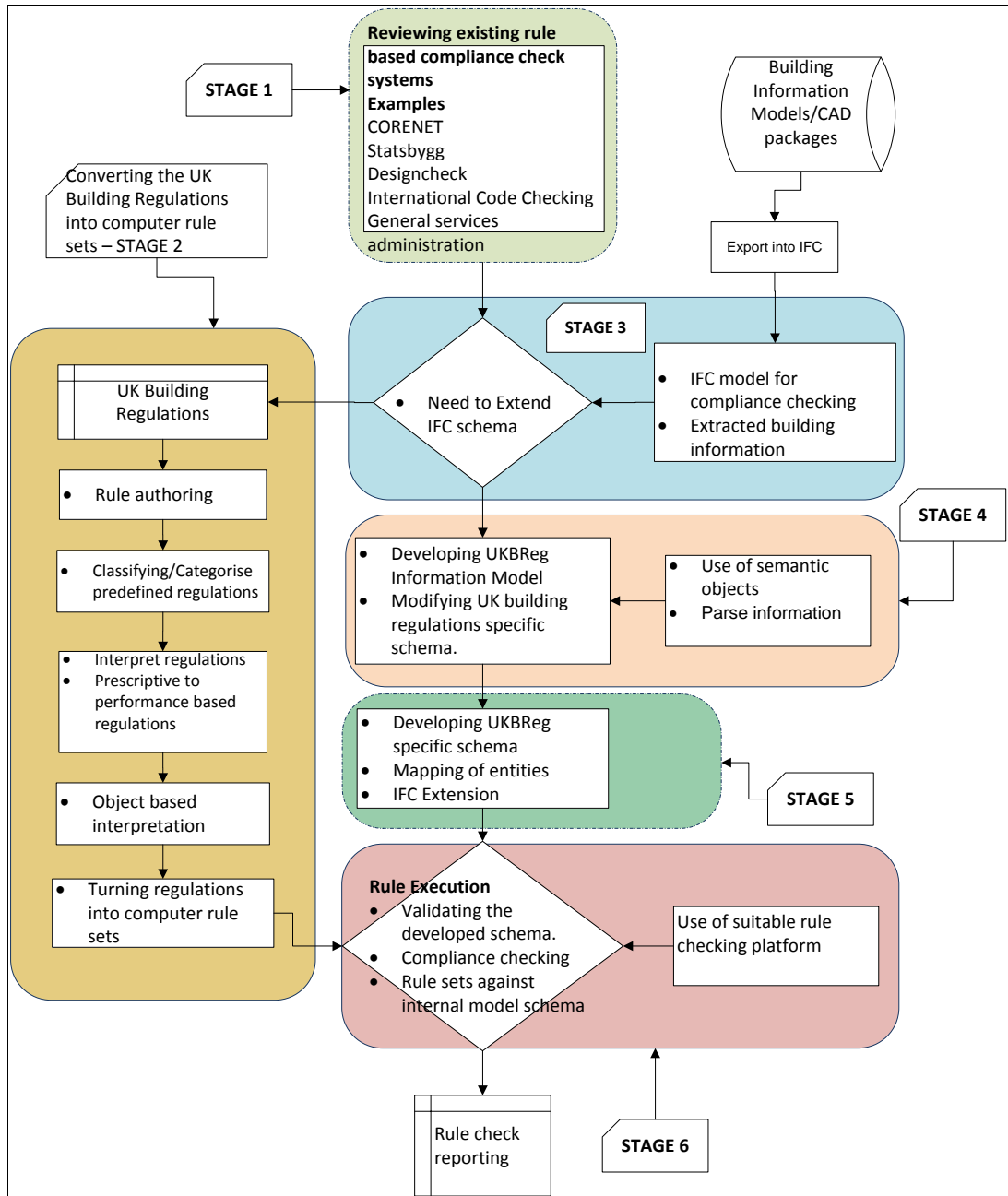

Figure 8.2: Conceptual overview of automated compliance checking

The conceptual overview for automated compliance checking of UK building regulations involves six stages. Stage one is about reviewing existing rule based compliance check systems for building regulations from different countries as shown in figure 8.2. It highlights the importance of understanding the work done in the compliance checking context (see section 2.3 and section 2.4) and to apply important learnings from them. It mainly emphasises on the importance of developing model checking softwares as per the country specific codes.

Stage-2 involves the conversion of the UK Building Regulations into set of computer interpretable rules. As mentioned in chapter 07 section 7.2, building regulation data in the form

of approved documents was utilised. This stage advocates the development of computable rule sets that can be implemented into a rule checking software.

Stage three and four defines the use of BIM over 2D drawings and the use of IFC data model for automated compliance checking. These stages of automated compliance checking methodology deal with the issue of lack of data (needed for code compliance) from the IFC file; this is because IFC file often only represents the basic geometrical building information which can be modelled by a BIM application. That is why it was important to have a building model which is consistent with the rules to be checked, possessing needed IFC entities and properties. Stage four is about enriching building model IFC schema with required information by defining and entering new objects with required attributes. It is about developing a country specific building regulation schema which is very well described in this research in chapter 06, section 6.3. Stage five and six describes mapping between UK entities and IFC, which results into a file which could be checked against the developed rule sets. IFC files can be checked for suitability based on pre-defined computer interpretable rules which are consistent with functions. Such compliance check application can also provide a well developed reporting system with 3D visualisation.

8.3.1 Implications on practice

The research work undertaken results in the form of a detailed framework for automated compliance checking. It has implications on the current practices of building regulations compliance checking and as a whole on the AEC industry.

On the basis of this research work, RIBAE created an elemental view of the building regulations. This elemental view helps in understanding the impact of clauses on individual building objects and is maintained via a complex matrix showing building objects and their relationship to building regulations clauses and the classification system UNICLASS. This effort highlighted the importance of authoring of building regulations keeping objects at the forefront. This work was further continued and extended resulting into the creation of National BIM Library by NBS in 2012.

Development of NBS library by RIBA Enterprises shows that the research output has a significant relevance to the industry's requirements. The NBS National BIM Library contains thousands of generic BIM objects from leading UK and global manufacturers. BIM objects are construction product information presented in a 3D format. They are freely available and are authored by NBS technical experts. BIM objects are created to comply with the NBS BIM Object Standard, a global standard providing high quality BIM objects.

The development of an Xbim toolkit, a model checking software is one such example. It is also very well explained in section 2.2.7. It is developed to check the UK building regulation specific data model for its compliance related validation. Xbim toolkit provides step-by-step help to define manage and validate responsibility for information development and delivery at each stage of the asset lifecycle.

The research advocates and validates the use of BIM over 2D drawings for automated compliance checking. Also it is well documented how AEC industry is shifting from 2D to 3D CAD in section 3.3, which shows this research work's applicability in the industry.

8.4 Limitations

This research work achieved all set objectives and how it contributes to knowledge is explained above in detail. The output of the research work is in the form of an England and Wales building regulations specific object data model, as well as a legislative document modelling methodology. However, this research, like any other, has limitations and shortcomings related to its conduct and scope. These limitations provide the basis for recommendations, discussed hereunder, for future research.

8.4.1 Limitations with regards to data collection and data sampling

The aim of this research was to optimise the feasibility of digitising England and Wales building regulations to support automated compliance checking using BIM standards. It was a challenging task, in particular due to the large volume of building regulations and their unsuitable nature for use in automated compliance checking. An overview of the structuring of England and Wales building regulations showed there are in total 2669 clauses in fourteen approved documents. It was not possible to consider all clauses published and classify them; hence an appropriate sample was selected. The Approved Document Part B1-Fire Safety was considered as part of the sampling process. It acted as a source of representative data to extract semantics for the data model development. Although the objective was to optimise building regulations, due to the large volume of regulations the scope had to be limited to a sample approved document.

8.4.2 Limitations with regards to the review of systems

It was important to review various attempts at code compliance checking by different countries. A critical review of code compliance related implementation efforts was carried out. It was observed that both in literature and in practice there has been limited progress in automated compliance checking development. In this research, five such systems were studied and interpreted, with secondary data collected in the form of web based case studies, recorded and

documented. The study of various code compliance checking approaches was conducted as desk based research, as it was not possible to visit different countries to understand more about their efforts. Hence, the researcher had to rely on whatever data was published through various means of publication and this can be seen as a limitation. Also, it was observed that since these systems are in their developing stages, not all information on them has been published, which hindered progress and limited the scope.

8.4.3 Limitations with regards to the use of a framework

Due to the unsuitability of approved documents it was decided to optimise their viability for use in automated compliance checking. The study undertook this challenge and it resulted in the development of a methodology for modelling a technical document (e.g. Part B1, Part B2). Using this methodology building regulation data decomposition was achieved. With the help of Express-G language, along with an object oriented approach, a building regulation specific object data model was generated. The methodology was designed in a way that it is applicable to all parts (e.g. Part G, Part M) of the England and Wales building regulations or to any similar legislative document which has a human linguistic format. By following the developed sequential steps, the said methodology was implemented on a sample legislative document to check its usefulness. However, the application of this developed framework was limited to only a sample approved document (Part B1) due to time and scope constraints. Given more time and resources the researcher would have liked to apply it on a few more approved documents to show its validity and worth.

8.5 Recommendations for future research

8.5.1 Recommendations to building model authors

Through this research, the importance of preparation or authoring of a building model to make use of it in the UK automated compliance checking process was established. At present the focus of building model authors is largely on visualisation rather than building information and they are partly limited in making models more semantically rich due to the incapability of software applications to allow the same. As a result, current BIMs are not semantically detailed enough for use in the automated building regulation compliance checking process. From an automated building regulation perspective, additional focus is required on the process of building model authoring by the design team to incorporate more and more information related to building regulations into building models. In the context of automated compliance checking, model authors do not focus on adding the required England and Wales building regulation specific information as it is not the established practice yet. If they want to then software applications must be developed that will help them to do so. Model authors also need help with

producing formalised data from the building regulations that are readily available so that they can include them in building models.

8.5.2 Recommendations in relation to document authoring

The England and Wales building regulations consist of ‘requirements’, within which each ‘part’ or ‘approved document’ sets out the broad objectives or functions of individual aspects of the building design and construction in a subjective manner. These are termed ‘functional requirements’ and are expressed in terms of individual clauses which set out what is reasonable, adequate or appropriate for achieving compliance. Most are informative or suggestive in nature, and can be incomplete in terms of expectation or contradictory in nature. It was observed that the England and Wales Building Regulations ‘Approved Documents’ consist of clauses that are written in a natural linguistic format. They represent complex, subjective information. Hence, it was concluded that in their present form they are not suitable for automated compliance checking. Taking into account all such issues related to building regulations, constructive recommendations have been made to building regulation authors so as to increase their suitability for automated compliance checking.

- An overview of the England and Wales building regulations proved that entities or objectified concepts are often terminologically inconsistent, both within an approved document and across approved documents. Building regulation document authors should make sure that terminologies are used consistently.
- In the context of England and Wales, it is important to have building regulations that are responsive to the opportunities provided by recent technical developments, such as the emergence of BIMs. Building regulation authors should author in such a way that semantic information can be easily taken out and incorporated into building models.
- Building regulations are complex and at times subjective in nature, therefore building regulation experts need to be involved in their conversion to computer interpretable rules to ensure the correct interpretations for code checking. At the moment, software developers are expected to deal with the prediction of meaning from building regulations, which is not correct. Building regulation authors can contribute towards solving this problem by authoring regulations such that their conversion to computable rule sets would be smooth without there being concern about the loss of integrity of intent.
- The England and Wales building regulations are composed of 14 different parts which are updated frequently and individually for reasons such as changes in the law, consultation processes and extraordinary events. Since these 14 parts represent different specialised domains, they each get updated from the respective subject specialist author. This has resulted in a situation where, from a code compliance point of view, continuity

and consistency across the regulations is sometimes missing. It is recommended to have coordination and communication between these subject specialists or document authors.

8.5.3 Recommendations in relation to open standards

To create a BIM, a modeller uses semantically rich objects to build a virtual prototype. The resulting 3D integrated model is a far more rich representation of a building project than the traditional 2D drawings. The ability to attach ‘properties’ to objects means that the use of BIM is potentially a far more convincing instrument in communicating building designs in terms of obtaining sanction from the rule checking authorities. However, for communicating building regulation related information to rule checking tools, use of an appropriate open standard is significant. In this context, recommendations can be made to software authors.

- There are several open standards for building models but our research to date has suggested that the most comprehensive, for the purpose of regulatory control, are the IFCs. Other standards such as CityGML and GBXML are targeted at a specific use and do not model the concepts to the required depth from a compliance checking perspective.
- BIM software tool authors need to understand the role of IFC as an interoperability standard and make their products compatible to it. The full benefits of BIM will materialize only through sharing of information across organisations, departments, information technology systems and databases, and for that to happen IFC is important. IFCs are widely adopted by the major CAD vendors and are generally accepted as the standard most likely to succeed.

8.6 Closing Remarks

This chapter provided a discussion and summary of the overall results, explaining how the set objectives were achieved and conclusions drawn. It included discussion on the original contributions made through the research findings, as well as limitations and recommendations. The main aim of this research was to investigate the potential for digitisation of the England and Wales Building Regulations and to develop a method to construct an England and Wales building regulation specific object data model that enables automated compliance checking. In order to achieve this aim a set of objectives were formulated (see Section 1.3). Table 8.3 gives a brief description of each of the objectives and the corresponding chapters in which they were achieved

Table 8.3: Research objectives and respective chapter numbers

No.	Objective	Method/Description	Chapter Number
i.	To review England and Wales Building Regulations in terms of their structure, nature and suitability	Literature review: England and Wales Building Regulations in terms of their structure	02
ii.	To conduct a critical review and a comparative analysis of existing automated code compliance checking systems	Literature review: (1) Desk based case study approach (2) Comparative analysis and acquiring learnings from it	03 and 04
iii.	To optimise feasibility by extraction of computer interpretable rules from the England and Wales Building Regulations data	(1) Formulation of knowledge formalisation process (2) Application of it to extract required information	05
iv.	To develop an England and Wales Building Regulation specific object based data model schema for code compliance checking	(1) Use of formalised data to build the data model (2) Use of Express – G language	06
v.	To validate the developed legislative document modelling methodology by applying it to a generic document	(1) Selection of generic house rules document (2) Applying the developed framework to validate it	07

This thesis presents a framework to construct an England and Wales building regulation specific object data model which can help in enabling automated compliance checking. It addresses all the critical issues related to UK automated compliance checking, such as the unsuitability and complexity of UK building regulations, building models with limited information, interoperability, compliance with open standards, use of rule sets, creation of data models with national semantics, etc., and may be used as a reference or tool for practically executing automated compliance checking for different sections of UK building regulations.

References

- Auel, J. (2005). *Data Modelling Basics* (3rd ed.). New York: United Services Group.
- Autodesk. (2008). BIM and Facilities Management (white paper). 02(1st), pp. 31-39. Retrieved from <http://www.autodesk.com/industry/architecture-engineering-construction/building-owner-operations-management> website:
- Azhar, S., Brown, J., & Farooqui, R. (2009). BIM-based Sustainability Analysis: An Evaluation of Building Performance Analysis Software. *International Journal of Construction Education and Research*, 05(04th), pp. 276-292.
- Bailey, P., Brodtkin, D., Hainsworth, J., Morrow, E., & Simpson, M. (2008). The Virtual Building *The Arup Journal* (Vol. 43, pp. 15-25). London: Corporate Communications Group.
- Batini, C., Ceri, S., Kant, S., & Navathe, B. (1991). *Conceptual Database Design: An Entity Relational Approach* (5th ed.). London: The Benjamin/Cummings Publishing Company.
- Bazjanac, V. (2002). *Early lessons from deployment of IFC compatible software* Paper presented at the European Community Product and Process Modeling Conference (ECPPM 2003), Portoroz, Slovenia.
- Beetz, J. (2009). *Facilitating Distributed Collaboration in the AEC/FM Sector using Semantic Web Technologies*. (PhD thesis), Eindhoven University of Technology, The Netherlands., Eindhoven. Retrieved from <http://alexandria.tue.nl/extra2/200911977.pdf>
- Bell, H., Bjorkhaug, L., & Hjelseth, E. (2009). Standardised computable rules (pp. 1-67). Oslo: National Office of Building Technology and Administration and Statsbygg.
- Bernstein, P., & Pittman, J. (2004). Barriers to the Adoption of Building Information Modeling in the Building Industry (white paper). 14. Retrieved from www.autodesk.com website:
- Blaxter, L., Hughes, C., & Tight, M. (2010). *How to Research* (04 ed.). Buckingham: McGraw-Hill/Open University Press.
- Brandon, P., & Kocaturk, T. (2008). *Virtual Futures for Design, Construction and Procurement* London: Blackwell Publishing Ltd.
- Bryman, A. (2004a). Interviewing in Qualitative Research, Qualitative Data Analysis. *Social Research Methods*, 01(2nd), 318-321.
- Bryman, A. (2004b). *Social Research Methods* (4th ed. Vol. 3rd). New York: Oxford University Press Inc.
- BuildingSMART. (2008). BuildingSMART International. Retrieved 17 July, 2010, from <http://www.buildingsmart-tech.org/>
- Choi, J., & Kim, I. (2008). An approach to share architectural drawing information and document information for automated code checking system. *Tsinghua science and technology*, 13(5th), pp. 171-178.

- Conover, D. (2009). An introduction to building Information Modelling, a guide for ASHRAE members. 25. Retrieved from <http://www.ashrae.org/publications/page/540> website:
- Cresswell, J. (2003). *Research Design : Qualitative, Quantitative and Mixed Methods Approaches* (4th ed.). California: Sage Publication.
- Davies, M., & Raslan, R. (2010). An analysis of industry capability for the implementation of a software-based compliance approach for the UK Building Regulations. *Building Services Engineering Research and Technology*, 31(02), pp. 141-162. doi: 10.1177/0143624410362009
- DesignCheck. (2009). Automated code compliance check. *DesignCheck*. Retrieved 15 June 2010, from <http://www.cif.org/noms/2009/08 - Automated Code Compliance Check.pdf>
- Dimyadi, J., & Amor, R. (2013). *Automated Building Code Compliance Checking - Where is it at?* Paper presented at the 19th International Council for Research and Innovation in Building and Construction (CIB) World Building Congress, Brisbane.
- Ding, L., Drogemuller, R., Jupp, J., & Rosenman, A. (2006). *Automated code checking for building designs-DesignCheck*. Paper presented at the The Second International Conference-Clients Driving Innovation: Moving Ideas into Practice, Gold Coast. <http://www.irbnet.de/daten/iconda/CIB1687.pdf>
- Dix, T. (2009). *Bird's Nest Stadium and Revit*. Paper presented at the CIBSE National Conference, London.
- Eastman, C., Lee, J. M., Jeong, Y. S., & Lee, J. K. (2009). Automatic rule-based checking of building designs. *Automation in Construction*, 18(8th), pp. 1011-1033. doi: 10.1016/j.autcon.2009.07.002
- Eastman, C., Teicholz, P., Sacks, R., & Liston, K. (2008). *BIM handbook: a guide to building information modelling for owners, managers, designers, engineers and contractors*. New Jersey: John Wiley and Sons.
- Evelyn, T., & Fatt, C. (2004). Building Smart-a strategy for implementing BIM solution in Singapore. *Synthesis Journal*, 5(4th), pp. 117 - 124.
- Fellows, R., & Liu, A. (2008). *Research Methods for Construction* (3rd ed.). London: Wiley Blackwell.
- Fenves, S., Garrett, J., Kiliccote, H., Law, K., & Reed, K. (1995). Computer Representations of Design Standards and Building Codes. *The International Journal of Construction Information Technology*, 3(1st), pp. 13-34.
- Foster, L. (2010). *Legal Issues and Risks Associated with Building Information Modelling Technology*. (PhD Published Thesis), University of Kansas, Proquest.
- Froese, T., Han, Z., & Alldritt, M. (2007). Study of Information Technology Development for the Canadian Construction Industry. *Canadian Journal of Civil Engineering*, 34(5th), pp. 817-829. doi: 10.1139/L06-160

- Gao, X., Yue, H., & Gao, Q. (2008). Semantic-Parsing Based on Semantic Units Theory — A New Approach to Natural Languages Processing. *International Journal of Pattern Recognition and Artificial Intelligence*, 22(07th), pp. 1447–1459. doi: 10.1142/S0218001408006818
- Glaser, B., & Strauss, A. (1999). *The Discovery for Grounded Theory: Strategies for Qualitative Research*. USA: Aldine Transaction
- Gray, M., Kulkarni, K., & Paton, N. (1992). *Object Oriented Databases, A Semantic Data Model Approach* (3rd ed. Vol. 04). Trowbridge: Prentice Hall International (UK) Ltd.
- Greenwood, D., Lockley, S., Malsane, S., & Matthews, J. (2010). *Automated Compliance Checking using Building Information Models*. Paper presented at the Cobra 2010 RICS International Research Conference, Paris.
- GSA. (2007). BIM Guide for Spatial Program Validation. *GSA BIM Guide Series 02, 04*(3rd), pp.01-38. Retrieved from www.gsa.gov website:
- Hamil, S. (2011). BIM Oppurtunities. Retrieved from <http://constructioncode.blogspot.in>
- Han, L. (2005). Building Smart - A Strategy for Implementing BIM Solution. *05*, pp. 117-125. Retrieved from http://www.jacic.or.jp/acit/3-2_appendix.pdf website:
- Haraldsen, M., Stray, T., Päivärinta, T., & Sein, M. (2004). *Developing e-government portals: From life-events through genres to requirements*. Paper presented at the 11th Norwegian Conference on Information Systems, Stavanger, Norway
- Hiekkila, E., & Blewitt, E. (1992). Using expert systems to check compliance with municipal building codes. *Journal of the American Planning Association*, 58(1st), pp. 72-80. doi: 10.1080/01944369208975536
- Hjelseth, E. (2009). *Foundation for development of comutable rules*. Paper presented at the CIB-W78 Conference-Managing IT in Construction Conference, Istanbul, Turkey.
- Hjelseth, E. (2012). *Converting performance based regulations into computable rules in BIM based model checking software*. Paper presented at the 9th European Conference on Product and Process Modelling (ECPPM) Conference, Reykjavik, Iceland.
- Hjelseth, E., & Nisbet, N. (2010). *Overview of Concepts for Model Checking*. Paper presented at the 27th CIB W078 International Conference, Cairo, Egypt.
- Holtz, B., Orr, J., & Yares, E. (2003). The Building Information Model: A Look at Graphisoft's Virtual Building Concept (pp. 201-210). Bethesda, USA: Cyon Research Corporation.
- Holzer, D. (2009). *Are you talking to me? why BIM alone is not the answer*. Paper presented at the Fourth International Conference of the Association of Architecture, Australia. <http://hdl.handle.net/2100/476>
- Jaeger, S., & Harelik, L. (1985). Automation of the Building Code Compliance *National Bureau of Standards Special Report* (pp. 37-44). USA: US Department of Commerce.

- Jeong, J., & Lee, G. (2008). Requirements for automated code checking for fire resistance and egress rule using BIM. *Korean Institute of Construction Management*, 03(1st), pp. 101-107.
- Jones, S. (2007). Interoperability in the Construction Industry. In N. Young (Ed.), *SmartMarket Report : Design and Construction Intelligence* (2007 ed., pp. 31). New York.
- Kantardzic, M. (2003). *Data Mining Concepts, Models, Methods, and Algorithms*. Piscataway: A John Wiley and Sons, Inc.
- Khemlani, L. (2004). The IFC Building Model: A look under the hood. *AECBytes Feature*, 9, pp. 1-9. Retrieved from www.aecbytes.com website:
- Khemlani, L. (2005). CORENET e-planCheck: Singapore's Automated Code Checking System. *The AECBytes Feature*, 1-7. Retrieved from <http://www.aecbytes.com/buildingthefuture/2005/CORENETePlanCheck.html> website:
- Khemlani, L. (2009). Solibri model checker. *AEC bytes product review*, (1st). Retrieved from <http://www.aecbytes.com/review/2009/SolibriModelChecker.html> website:
- Kiviniemi, A. (1999). IAI AND IFC- State of the art. 02(01), pp. 01-12. Retrieved from <http://www.irbnet.de/daten/iconda/CIB2263.pdf> website:
- Krygiel, E., & Nies, B. (2008). *Green bim:successful sustainable design with building information modelling*. Indianapolis,Canada: Wiley Publishing,Inc.
- Kymmell, W. (2008). *Building information modelling : planning and managing construction projects with 4D CAD and simulations* (P. Scott Ed. Vol. 1). USA: The McGraw Hill Companies.
- Lau, G., Kerrigan, S., Law, K., & Wiederhold, G. (2004). *An E-government information architecture for regulation analysis and compliance assistance*. Paper presented at the 6th international conference on electronic commerce, Netherlands.
- Lee, K. (2008). *Programming Languages,an active learning approach*. Decorah, Iowa: Springer science.
- Lee, T. (2000, Sepember). *Information Modeling : From Design to Implementation*. Paper presented at the Second World Manufacturing Congress, National Institute of Standards and Technology,Gaithersburg, MD.
- Levy, Y., & Ellis, T. (2006). A Systems Approach to Conduct an Effective Literature Review in Support of Information Systems Research. *Informing Science Journal*, 09(01st), pp. 181-212.
- Lockley, S., Malsane, S., & Matthews, J. (2013). *An Object Model Development for the UK Automated Compliance Checking*. Paper presented at the The Construction, Building and Real Estate Research Conference of the Royal Institution of Chartered Surveyors, New Delhi.

- Love, P., Simpson, I., Hill, A., Matthews, J., & Olatunji, O. (2014). Benefits realization management of building information modelling: Obtaining value for asset owners. *Automation in Construction*, 37(3rd), pp. 1-10. doi: 10.1016/j.autcon.2013.09.007
- Marshall, M. (1996). *Sampling for Qualitative Research* (3rd ed. Vol. 13). London: Blackwell Publications.
- Nawari, N. (2012). The Challenge of Computerizing Building Codes in a BIM Environment. *Journal of Computing in Civil Engineering*, 1(3rd), pp. 285-292. doi: <http://dx.doi.org/10.1061/9780784412343.0036>
- Nazar, K., & Bramer, M. (1997). *Knowledge Discovery and Data Mining*. London: The Institution of Electrical Engineers, London.
- NBS. (1996). Planning Portal. Retrieved 10 Sept 2010, 2010, from <http://www.planningportal.gov.uk>
- Neuman, W. (2007). Survey Research, Analysis of Qualitative data. *Basics of Social Research Qualitative and Quantitative approaches*, 2nd(1st), 186-190.
- Nguyen, T. (2005, June 14-16). *Integrating building code compliance checking into a 3D CAD system*. Paper presented at the International Conference on Computing in Civil Engineering 2005, Cancun, Mexico.
- Niemeijer, R., Vries, B., & Beetz, J. (2009). *Check-mate: automatic constraint checking of IFC models*. Paper presented at the Managing IT in construction, Istanbul, Turkey.
- Oliver, P. (2004). *Writing Your Thesis* (3rd ed. Vol. 03). London: Sage Publications.
- Pratt, M. (2001). Introduction to ISO 10303—the STEP Standard for Product Data Exchange. *Journal of Computing and Information Science in Engineering*, 03(1st), pp. 102-111. doi: 10.1115/1.1354995
- Reuter, F. (1998). Information Modelling - Getting Started with EXPRESS-G. 01(2nd), 08. Retrieved from <http://tc3.iec.ch/txt/xpress.pdf> website:
- RIBAEnterprises. (2006). Building Regulations 2006: Approved Document *Fire Safety Part B1: Dwellinghouses* (Vol. 1, pp. pp. 11-91). NBS, United Kingdom: RIBA Enterprises.
- Rooth, O. (2005). ByggSok - zoning, building and construction. 1st. Retrieved 02 January, 2013, from <http://www.dibk.no/byggsok/>
- Salama, D., & El-Gohary, N. (2011). *Semantic modelling for automated compliance checking*. Paper presented at the International Workshop on Computing in Civil Engineering 2011, Miami, Florida.
- Sanguinetti, P., Eastman, C., & Augenbroe, G. (2009). *Courthouse energy evaluation : Bim and Simulation Model Interoperability in Concept Design*. Paper presented at the 11th International IBPSA Conference, Glasgow.
- Satti, H., & Krawczyk, R. (2004). *Issues of Integrating Building Codes in CAD*. Paper presented at the 1st ASCAAD International Conference, Dhahran, Saudi Arabia.

- Schevers, H., & Drogemuller, R. (2006). *Converting the Industry Foundation Classes to the Web Ontology Language*. Paper presented at the First International Conference on Semantics, Knowledge, and Grid (SKG 2005), Beijing, China.
- See, R. (2008). *SMARTcodes: Enabling BIM Based Automated Code Compliance Checking*. Paper presented at the AEC-ST Conference Presentation, Anaheim, USA.
- Silverman, D. (2005). *Doing Qualitative Research* (3rd ed. Vol. 2005). Los Angeles: SAGE Publications Ltd.
- Sing, T., & Zhong, Q. (2001). Construction and Real Estate NETWORK (CORENET). *Emerald Facilities*, 19(11/12), pp. 419-428. doi: <http://dx.doi.org/10.1108/EUM0000000005831>
- Solibri, I. (1999). Solibri Model Checker. Retrieved 26 July 2010, from <http://www.solibri.com/solibri-info/about-solibri.html>
- Solihin, W. (2004). Implementing IFC: Automatic Code Checking (e-PlanCheck). (01), 11. Retrieved from www.novacitynets.com website:
- Stumpf, R., Ganeshan, R., Chin, S., & Liu, L. (1996). Object-oriented model for integrating construction product and process information. *Journal of Computing in Civil Engineering*, 10(3), pp 204-212. doi: [http://dx.doi.org/10.1061/\(ASCE\)0887-3801\(1996\)10:3\(204\)](http://dx.doi.org/10.1061/(ASCE)0887-3801(1996)10:3(204))
- Succar, B. (2009). Building information modelling framework: A research and delivery foundation for industry stakeholders. *Automation in Construction*, 18(3), pp 357-375. doi: 10.1016/j.autcon.2008.10.003
- Sullivan, C. (2007). AIA/architectural record continuing education series. *Integrated BIM and design review for safer, better buildings*, pp 191-197.
- Tan, X., Hammad, A., & Fazio, P. (2010). Automated Code Compliance Checking for Building Envelope Design. *Journal of Computing in Civil Engineering*, 24(2), pp 203-211. doi: [http://dx.doi.org/10.1061/\(ASCE\)0887-3801\(2010\)24:2\(203\)](http://dx.doi.org/10.1061/(ASCE)0887-3801(2010)24:2(203))
- Thomas, D. (2006). A General Inductive Approach for Analysing Qualitative Evaluation Data. *American Journal of Evaluation*, 27(2nd), pp 237-247.
- Trochim, W. (2006). The Research Methods Knowledge Base. Retrieved 31 January 2011, from Atomic Dog Publishing <http://www.socialresearchmethods.net/kb/citing.php>
- Vanier, D. (1989, 24-28 September). *Computerised Building Regulations*. Paper presented at the Municipal Code Administration Building Safety and the Computer, Winnipeg.
- Waterhouse, R., & Hamil, S. (2011). Building Information Modelling Report, the NBS. In R. Waterhouse (Ed.), (Vol. 01, pp. 21). Newcastle upon Tyne: RIBA Enterprises Ltd.
- Wix, J., Nisbet, N., & Liebich, T. (2008). *Using constraints to validate and check building information models*. Paper presented at the EWork and EBusiness in Architecture, Engineering and Construction: ECPPM 2008, Sofia, Antapolis.

- Woodbury, R., Burrow, A., Drogemuller, R., & Datta, S. (2000). Code Checking by Representation Comparison. *International Journal of Design Computing*, 3(1), pp221-230.
- Woodson, R. (2006). *International Building Code Companion*. New York: McGraw-Hill Companies.
- Yan, H., & Damien, P. (2008). *Benefits and Barriers of Building Information Modelling*. Paper presented at the 12th International Conference on Computing in Civil and Building Engineering, Beijing, Beijing.
- Yang, Q. (2003). IFC-compliant design information modelling and sharing. *Information Technology in Construction*, 08(2nd), pp1-14. doi: <http://www.itcon.org/2003/1>
- Yang, Q., & Xiang, L. (2001). *Representation and Execution of Building Codes for Automated Code Checking* Paper presented at the Proceedings of the Ninth International Conference on Computer Aided Architectural Design Futures, The Netherlands.
- Yang, Q., & Xu, X. (2004). Design knowledge modeling and software implementation for building codecompliance checking. *Science and Direct, Building and Environment*, 39(6), pp 689-697. doi: <http://dx.doi.org/10.1016/j.bbr.2011.03.031>
- Young, N., Jones, S., & Bernstein, H. (2007). SmartMarket Report Design and Construction Intelligence *Interoperability in the Construction Industry* (Vol. 01, pp. 31). New York: McGraw Hill Construction.

Appendix A: Fire Safety Object Data Model

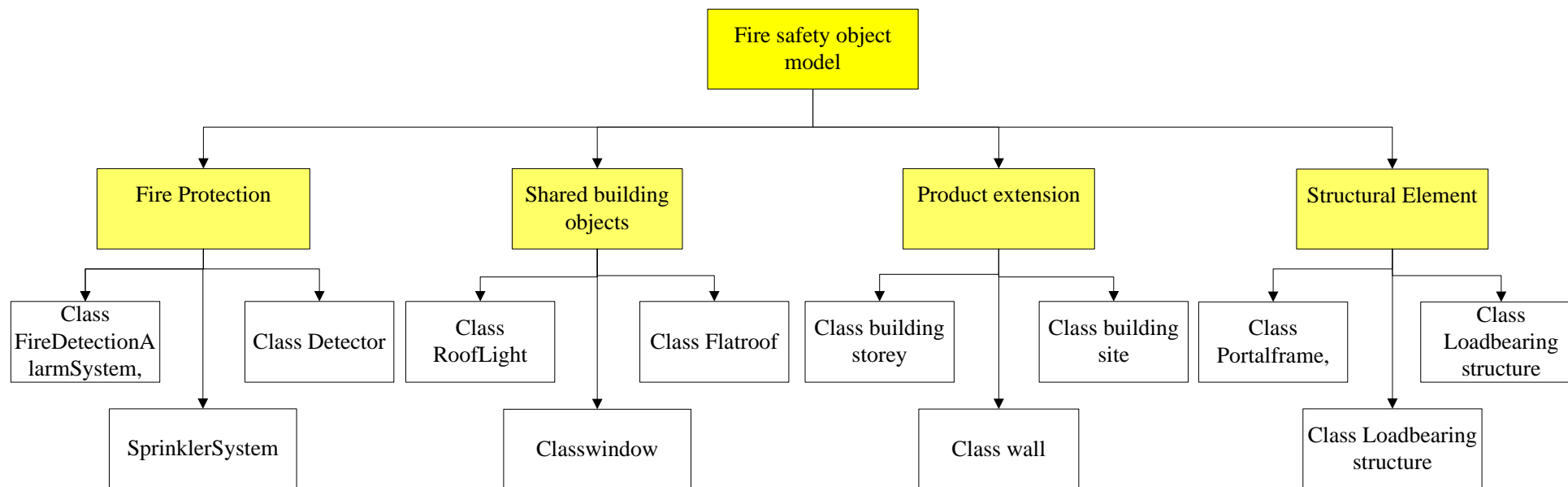

i. Overview of the developed fire safety object data model

The whole model is divided into suitable domain spaces. The domains formed highlighted above are *FireProtection*, *SharedBuildingObjects*, *StructuralElement*, *FireDetectionAlarmSystem*, *ProductExtention*, etc. In this way the developed data model was categorised into different domains which were suitable for integration with the IFC model.

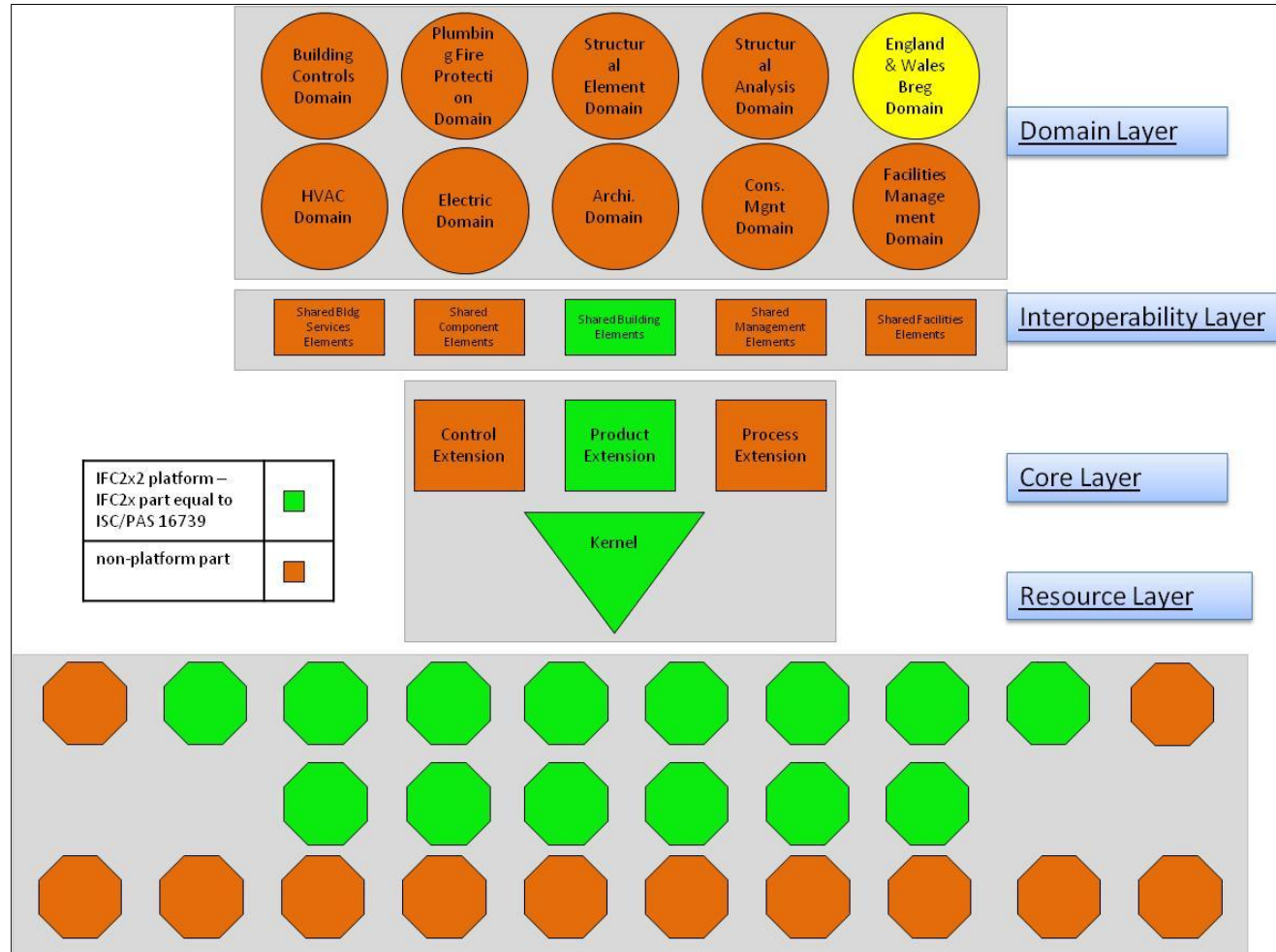

ii. Merging of IFC data model schema with the developed data model schema.

The UK building regulation specific data model was developed with having a similarity with IFC data model structure, which makes the integration easy.

Continuing with the same strategy of using the IFC model structure as a reference, all the entity classes related to respective domains are put together into the respective domain.

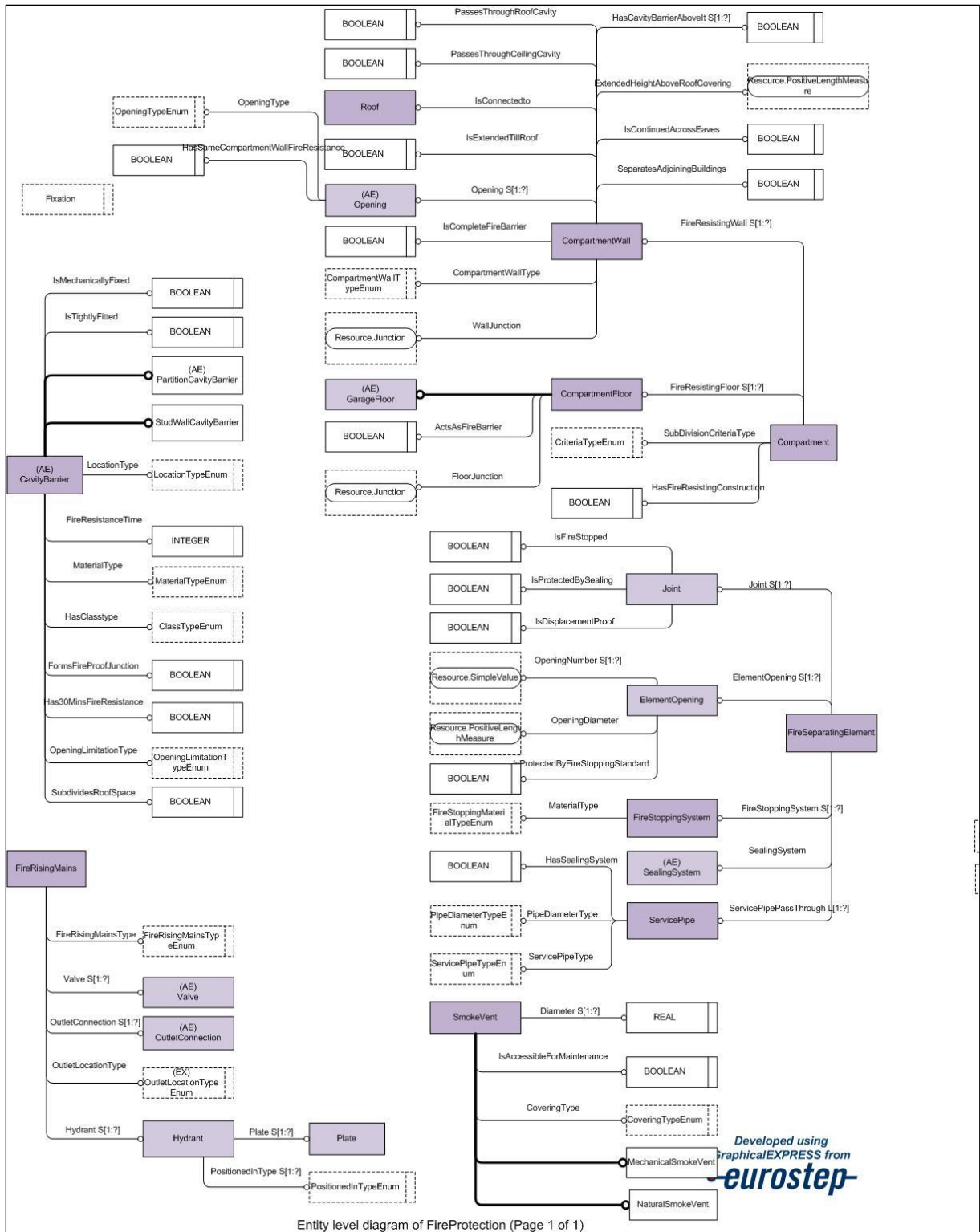

Entity level diagram of FireProtection (Page 1 of 1)

i. Domain FireProtection

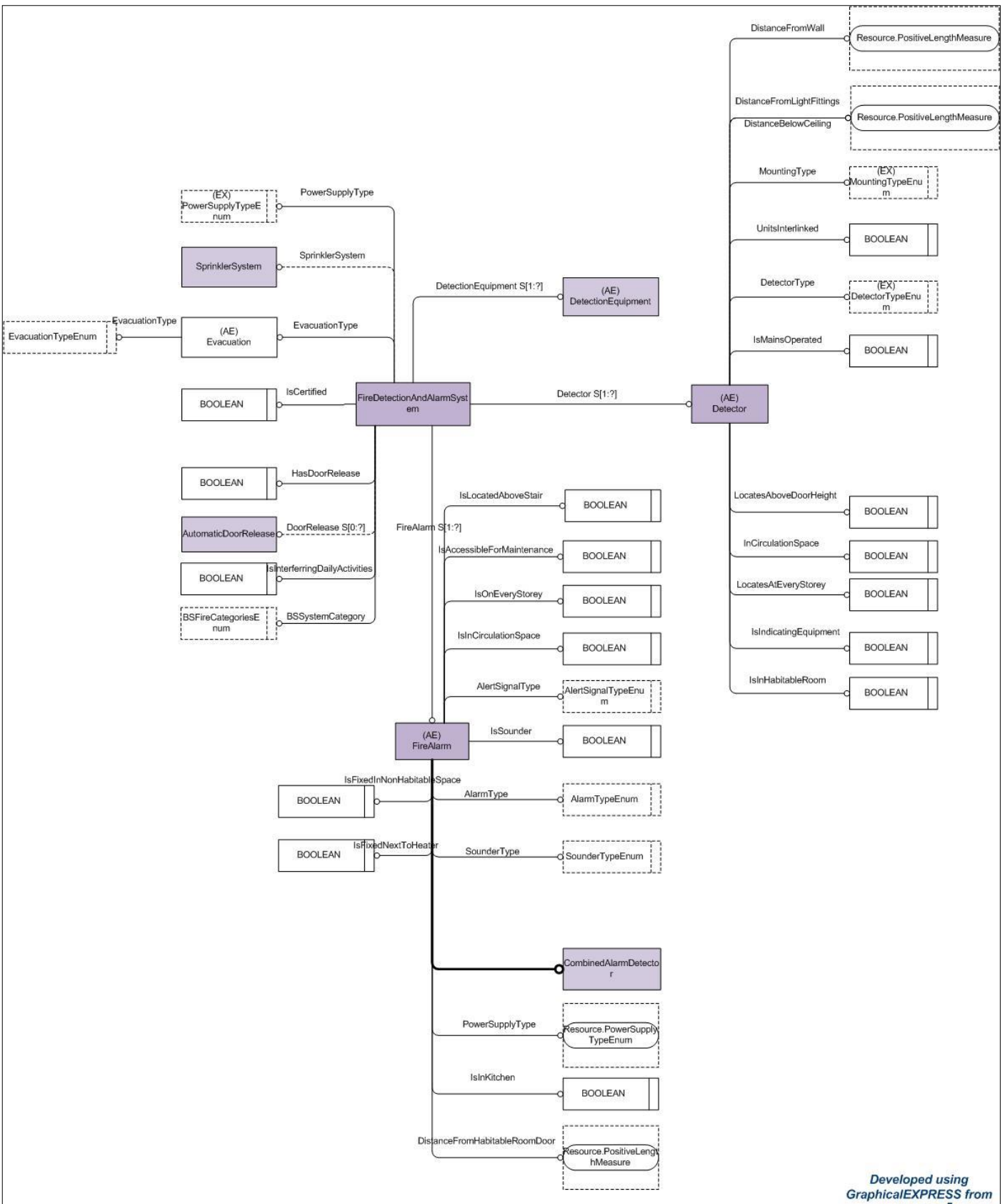

Developed using
GraphicalEXPRESS from

ii. Domain FireDetectionandAlarmSystem

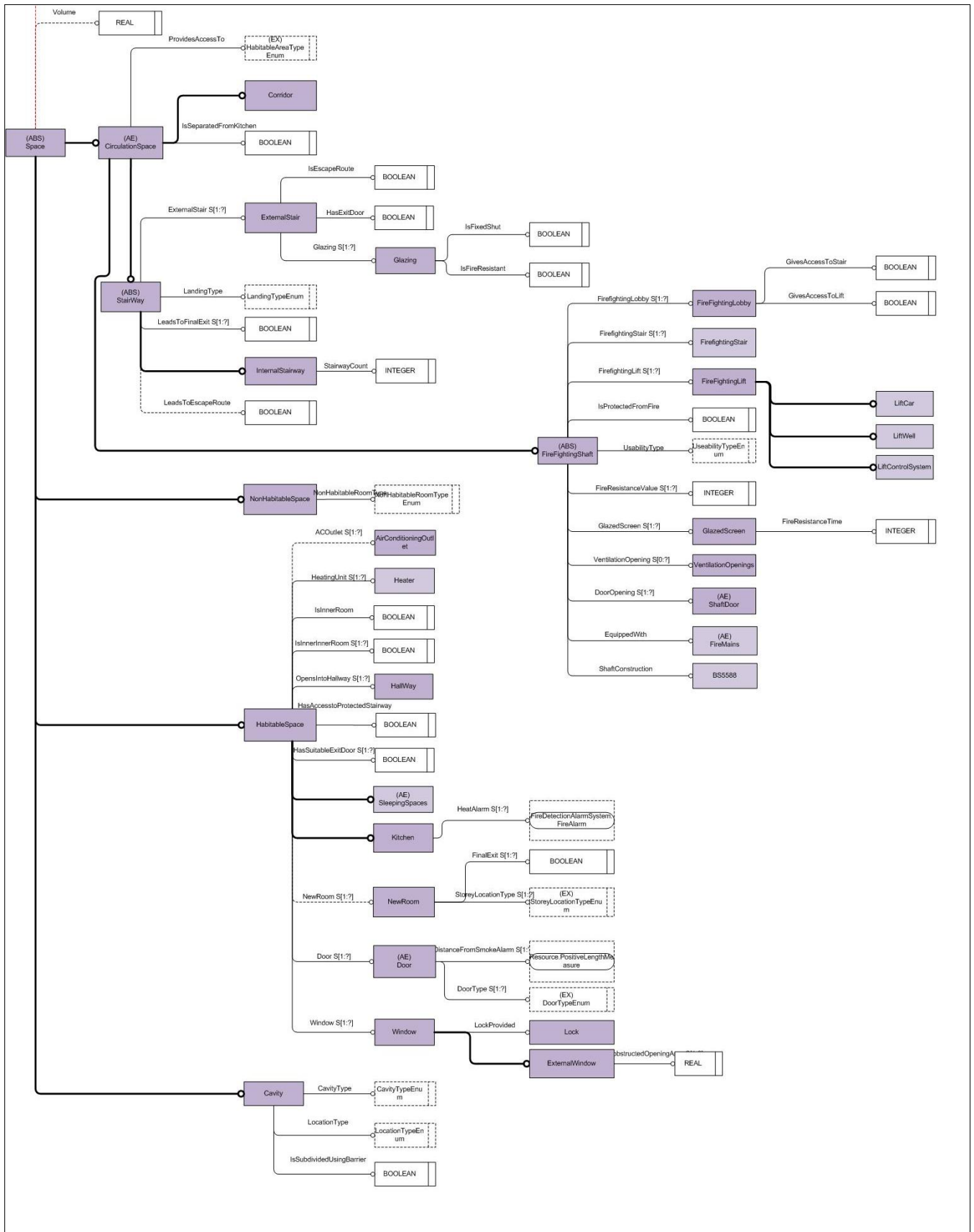

iii. Domain Space

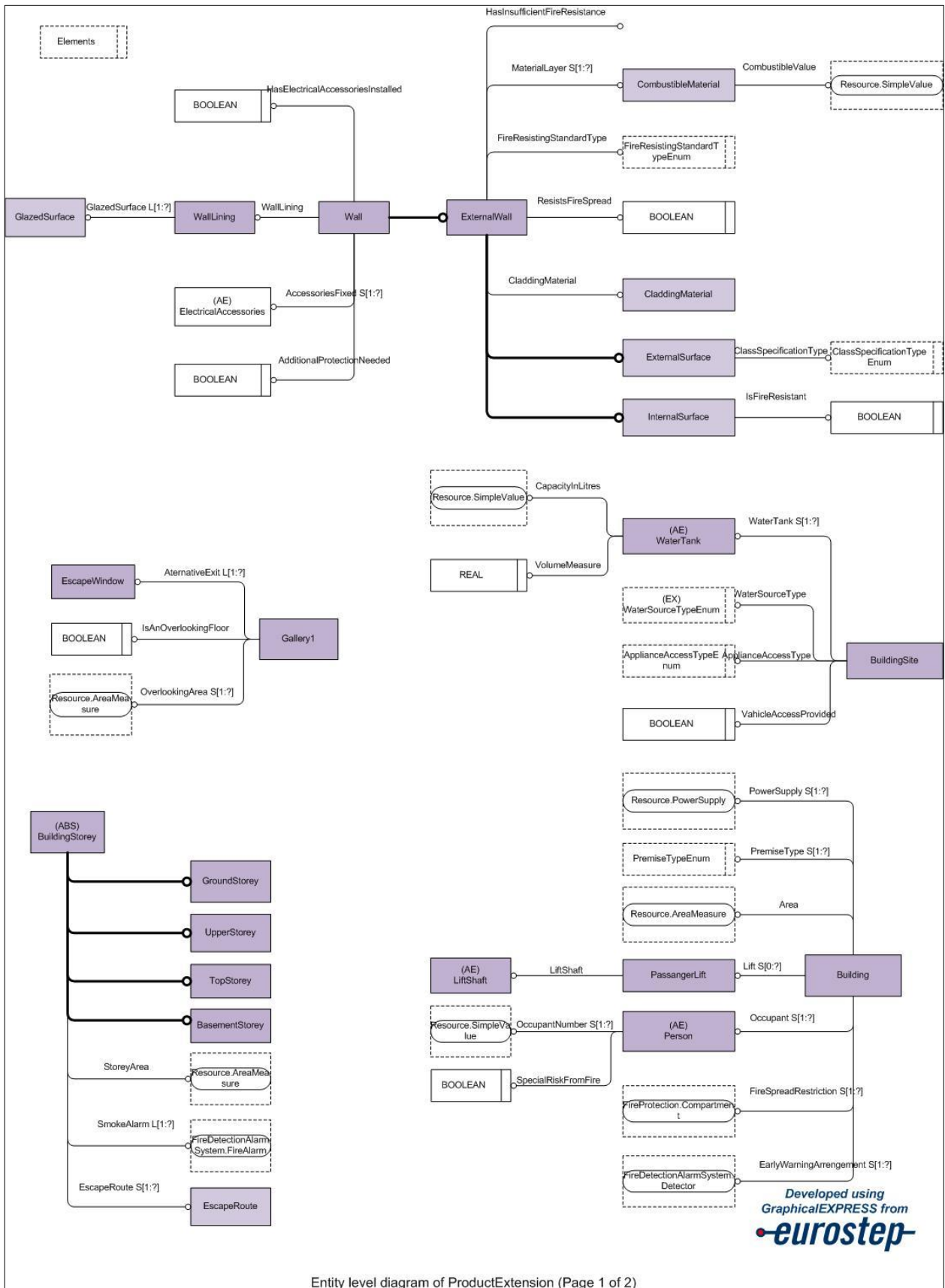

vi. Domain ProductExtension

Appendix B: Data analysis using filter system

Clause Level	Semantic Filter	Clause Semantic Filter Brief	Clause Number	
First Semantic Filter		Computer interpretable, testable rules (Rulish), Information obvious as checkable/can influence project parameters, Simple geometrical rules, well fitted for implementation. Boolean expression, parametric.	Clause 1.1	Clause 1.18
			Clause 1.3 BS	Clause 1.20
			Clause 1.4 BS	Clause 1.24
			Clause 1.5	Clause 2.8
			Clause 1.6	Clause 2.14
			Clause 1.8	Clause 5.3
			Clause 1.10	Clause 5.4 G
			Clause 1.11	Clause 5.7 G
			Clause 1.12	Clause 5.8 G
			Clause 1.13	Clause 5.14 G
			Clause 1.14	Clause 6.1 G
			Clause 1.15	Clause 6.7
			Clause 1.16	Clause 7.4
			Clause 1.17	
			27	

Clause Level	Semantic Filter	Clause Semantic Filter Brief	Clause Number	
Second Semantic Filter		Information in these clauses is not obvious to extract, Needs interpretation to understand the exact content and meaning, Codes/regulation done by software developer Involves natural language	Clause 1.2	Clause 4.1 G
			Clause 1.7	Clause 4.2
			Clause 1.9	Clause 4.5
			Clause 1.19	Clause 4.6
			Clause 1.21	Clause 4.7 G
			Clause 1.23	Clause 4.8 G
			Clause 2.1	Clause 5.1 G
			Clause 2.2	Clause 5.2 DG
			Clause 2.3	Clause 5.5 DG
			Clause 2.4	Clause 5.6
			Clause 2.5	Clause 5.9
			Clause 2.9	Clause 5.11
			Clause 2.10	Clause 5.13L
			Clause 2.11	Clause 6.5
			Clause 2.12 D	Clause 6.6
			Clause 2.13	Clause 6.7
			Clause 2.16	Clause 7.2
			Clause 2.17 G	Clause 7.3 D
			Clause 2.18 G	Clause 7.6 G
			Clause 2.19	Clause 7.7
			Clause 2.20 G	Clause 7.8 D
			Clause 3.1	Clause 7.9 D
			Clause 3.2 G	Clause 7.10 D
			Clause 3.3	Clause 7.11 D
			Clause 3.4	Clause 7.12 D
			Clause 3.5 DG	Clause 8.1
			Clause 3.6 DG	Clause 9.1 DG
			Clause 3.8	Clause 9.2 DG
			Clause 3.9 G	Clause 9.3 G
			Clause 3.10 DG	Clause 9.4 GD
			Clause 3.12	Clause 9.7 GD
			Clause 3.14D	Clause 9.10 DG
	Clause 9.13 G			
	Clause 9.15 DG			
		64		

Clause Level	Semantic Filter	Clause Semantic Filter Brief	Clause Number	
Third Semantic Filter (DIFFICULT) Pure Guidance		Complicated and lengthy clauses, semantics not obvious to extract, almost impossible, Lengthy guidance related to building regulations, Difficult for human interpretation, Involves human judgement	Clause 2.6 D	Clause 4.3DG
			Clause 2.7 D	Clause 4.5DG
			Clause 2.8 D	Clause 7.1 G
			Clause 2.15 D	Clause 7.5 G
			Clause 3.13 VD	Clause 7.10 G
			Clause 4.4 DG	Clause 7.13 GC
			Clause 5.10 D	Clause 7.14 G
			Clause 5.12 DG	Clause 8.2 G
			Clause 6.2 DG	Clause 8.3 G
			Clause 6.3 DG	Clause 8.4 G
			Clause 6.4 DG	Clause 9.5 G
			Clause 6.8 DG	Clause 9.6 G
			Clause 1.22	Clause 9.7 G
			Clause 1.23	Clause 9.8 G
			Clause 1.24	Clause 9.9 G
			Clause 3.1	Clause 9.11 G
			Clause 3.3	Clause 9.12 G
			Clause 3.4	Clause 9.14 G
			Clause 3.6	Clause 3.15
			Clause 3.7	Clause 4.4
Clause 3.9	Clause 4.9			
Clause 3.10	Clause 5.3			
Clause 3.11	Clause 5.4			
			46	

Appendix C: Compliance Checking Process

On the basis of research work undertaken, a conceptual overview of stages involved in automated compliance checking is explained.

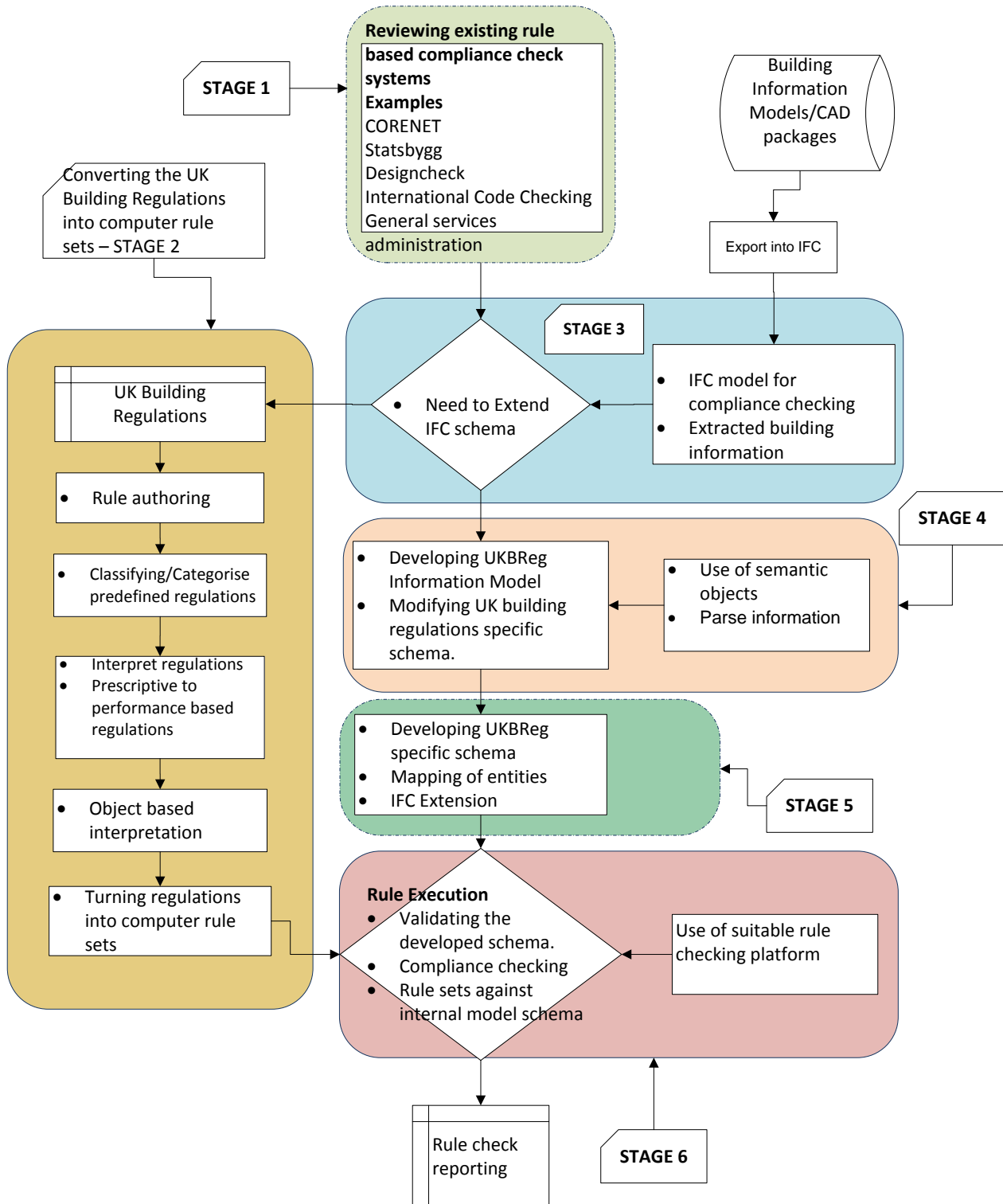

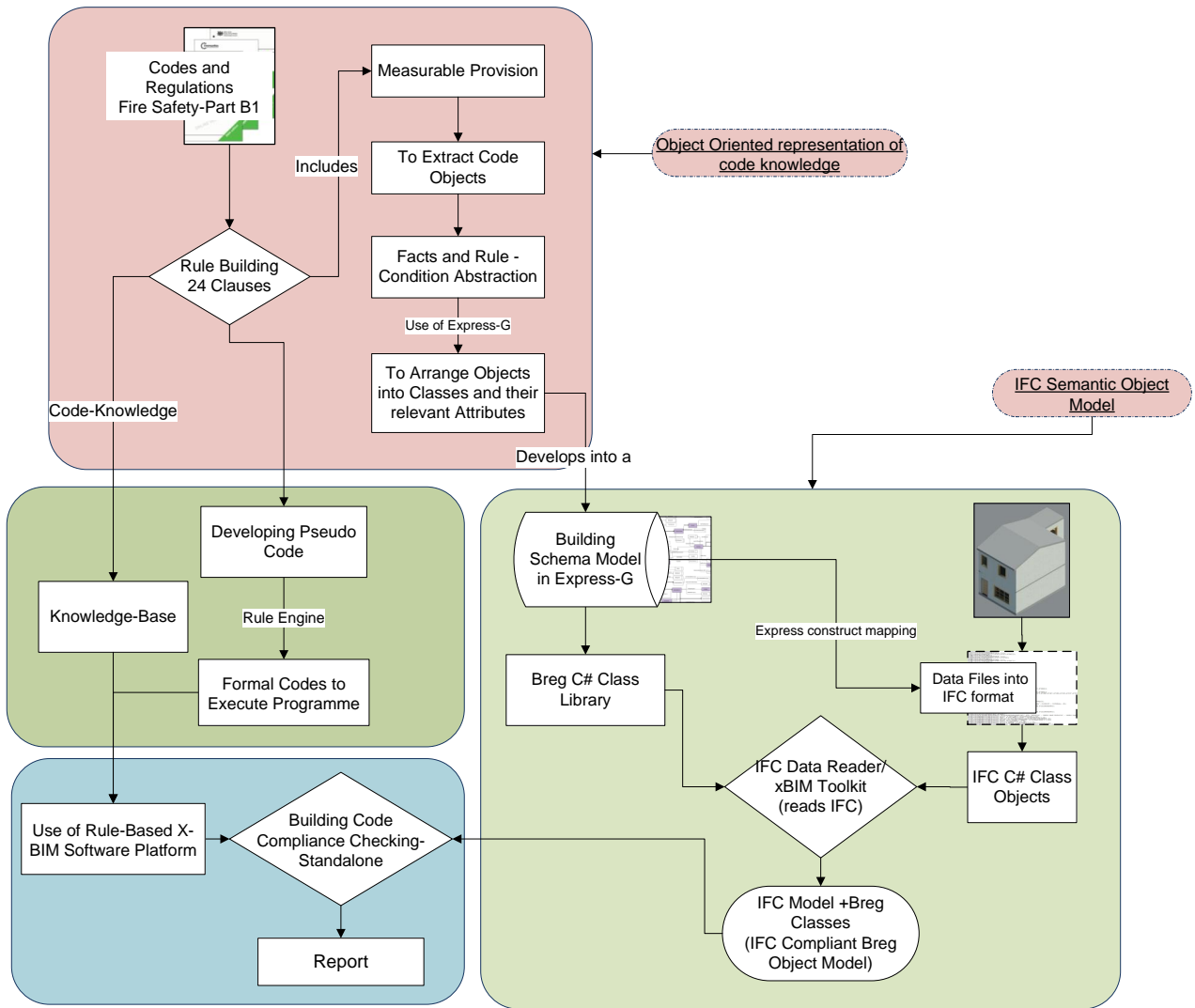

The Implementation of Building Regulation Representations in Software Systems

Appendix D: List of Publications

Sr. No.	Title	Key output	Place of publication
01	Automated compliance checking using building information models	It provides a review of the previous research into automated code compliance identifies the key issues for future development and examines the causes of information paucity for compliance checking in the current generation of BIM tools. It highlights that theoretically, building model could contain sufficient information to respond to interrogation at the level of building code compliance, though in practice only a percentage of the required information is normally present.	The Construction, Building and Real Estate Research Conference of the Royal Institution of Chartered Surveyors [Held at Dauphine University, Paris, 2-3 September 2010]. RICS, London. ISBN 978-1-84219-619-9
02	An object model development for the UK automated compliance checking	This paper presents the analysis of the UK fire safety building regulations for dwellinghouses, to determine and subsequently optimize the potential for automated compliance checking. Development of a UK Building Regulation specific semantically rich object model, appropriate for the requirements of automated compliance checking is presented.	RICS COBRA 2013 The Construction, Building and Real Estate Research Conference of the Royal Institution of Chartered Surveyors held in New Delhi, India in association with the University of Ulster and IIT Delhi, 10th-12th Sept 2013.
03	Development of an Object Model for Automated Compliance Checking	This paper explains role of IFC for automated compliance checking. However, it also questions whether the IFC data format can fully support the specialized needs of the UK Building Regulation or not. Knowledge formalisation concept is introduced and applied for modelling a legislative document. A Building Regulation-specific, semantically rich object model, appropriate for the requirement of automated compliance checking has been developed for England and Wales.	Malsane Sagar, Matthews Jane, Lockley Steve, Love Peter and Greenwood David (2015) Automation in Construction, 49 (Part A). pp. 51-58. ISSN 0926-5805
04	Building information modelling, a tool for green built environment	This paper explores, role of BIM methodology in the development of green built environment. It explains how a BIM based approach assists professionals during the conception of green built environment in predicting the outcome(s) of its construction to minimise its impact on the environment throughout its life-cycle.	Conference proceedings of All India Conference on Innovations in Green Building Technology, Nagpur, January 2014.

Appendix E: Building regulation fire safety part B1